











C.A 6528

Megohmmeter

Thank you for purchasing a **megohmmeter C.A 6528**.

For best results from your instrument:

- **read** these operating instructions carefully,
- **comply** with the precautions for use.

	WARNING, risk of DANGER! The operator must refer to these instructions whenever this danger symbol appears.
	Information or useful tip.
	Earth.
	Battery.
	Fusible.
	The voltage on the terminals must not exceed 700V.
	Equipment protected by double insulation.
	The product is declared recyclable following an analysis of the life cycle in accordance with standard ISO 14040.
	Chauvin Arnoux has adopted an Eco-Design approach in order to design this appliance. Analysis of the complete lifecycle has enabled us to control and optimize the effects of the product on the environment. In particular this appliance exceeds regulation requirements with respect to recycling and reuse.
	The CE marking indicates conformity with European directives, in particular LVD and EMC.
	The rubbish bin with a line through it indicates that, in the European Union, the product must undergo selective disposal in compliance with Directive WEEE 2012/19/EU.

Definition of measurement categories

- Measurement category IV corresponds to measurements taken at the source of low-voltage installations.
Example: power feeders, counters and protection devices.
- Measurement category III corresponds to measurements on building installations.
Example: distribution panel, circuit-breakers, machines or fixed industrial devices
- Measurement category II corresponds to measurements taken on circuits directly connected to low-voltage installations.
Example: power supply to electro-domestic devices and portable tools.

PRECAUTIONS FOR USE

This instrument is compliant with safety standard IEC 61010-2-034 and the leads are compliant with IEC 61010-031, for voltages up to 600 V in category IV.

Do not use the instrument for measurements on circuits that are not in measurement categories II, III, or IV or that might be connected inadvertently to circuits that are not in measurement categories II, III, or IV.

- The operator and/or the responsible authority must carefully read and clearly understand the various precautions to be taken in use. Sound knowledge and a keen awareness of electrical hazards are essential when using this instrument.
- If you use this instrument other than as specified, the protection it provides may be compromised, thereby endangering you.
- Do not use the instrument on networks of which the voltage or category exceeds those mentioned.
- Do not use the instrument if it seems to be damaged, incomplete, or poorly closed.
- Before each use, check the condition of the insulation on the leads, housing, and accessories. Any item of which the insulation is deteriorated (even partially) must be set aside for repair or scrapping.
- Before using your instrument, check that it is perfectly dry. If it is wet, it must be thoroughly dried before it can be connected or used.
- Use only the leads and accessories supplied. The use of leads (or accessories) of a lower voltage or category limits the voltage or category of the combined instrument and leads (or accessories) to that of the leads (or accessories).
- Use personal protection equipment systematically.
- When handling the leads, test probes, and crocodile clips, keep your fingers behind the physical guard.
- All troubleshooting and metrological checks must be performed by competent and accredited personnel.

CONTENTS

1. FIRST START-UP	4
1.1. Unpacking.....	4
1.2. Accessories and spares.....	4
1.3. Inserting the batteries	5
1.4. Using the protective sheath	6
2. PRESENTATION OF THE INSTRUMENT	7
2.1. C.A 6528.....	7
2.2. Functions	8
2.3. Display.....	8
2.4. Keys and button.....	9
3. USE	10
3.1. Checking the operation of the instrument.....	10
3.2. Voltage measurement.....	10
3.3. Insulation resistance measurement.....	12
3.4. Continuity measurement.....	15
3.5. Resistance measurement.....	18
3.6. HOLD function	19
3.7. Backlighting	19
3.8. SET-UP.....	20
3.9. Alarm function.....	21
3.10. Programmed duration.....	21
3.11. Automatic stop	22
4. TECHNICAL CHARACTERISTICS	23
4.1. General reference conditions	23
4.2. Electrical characteristics	23
4.3. Variations in the range of use	25
4.4. Intrinsic uncertainty and operating uncertainty	26
4.5. Power supply	26
4.6. Environmental conditions	27
4.7. Mechanical characteristics	27
4.8. Compliance with international standards.....	27
4.9. Electromagnetic compatibility (CEM).....	27
5. MAINTENANCE	28
5.1. Cleaning	28
5.2. Replacing the batteries.....	28
5.3. Replacing the fuse.....	28
5.4. Calibrating the instrument.....	29
6. WARRANTY	32

1. FIRST START-UP

1.1. UNPACKING

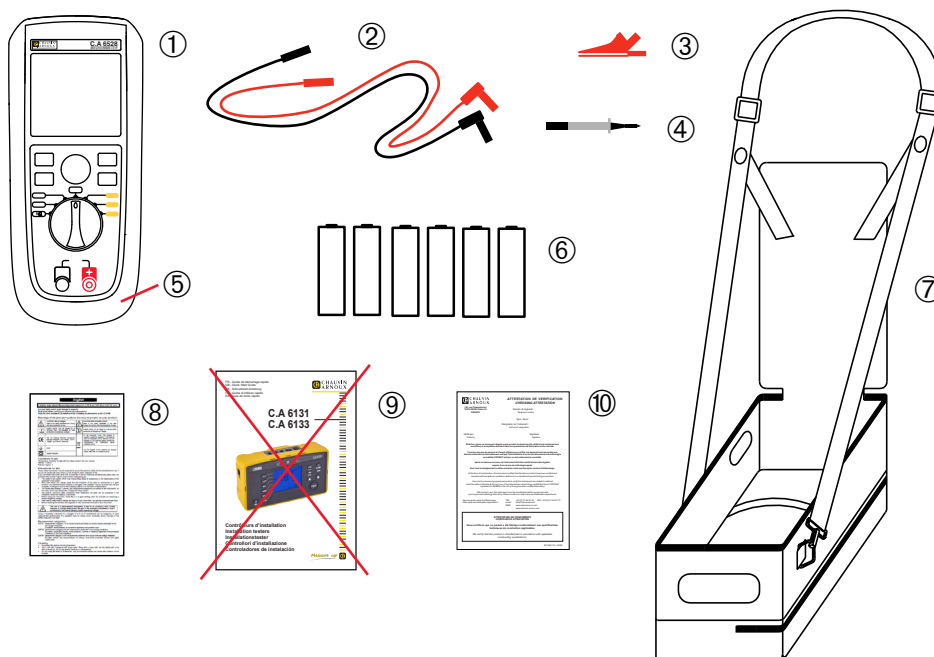

- ① One C.A 6528.
- ② Two straight/right-angle safety leads (red and black).
- ③ One red crocodile clip.
- ④ One black test probe.
- ⑤ One protective sheath fitted on the instrument.
- ⑥ Six LR6 or AA batteries.
- ⑦ One carrying case.
- ⑧ One multilingual safety data sheet.
- ⑨ One multilingual getting started guide
- ⑩ One certificate of verification.

1.2. ACCESSORIES AND SPARES

For the accessories and spares, consult our web site:

www.chauvin-arnoux.com

1.3. INSERTING THE BATTERIES

- Remove the protective sheath. Start by freeing the case from the top of the sheath.
- Then withdraw the case from the sheath.

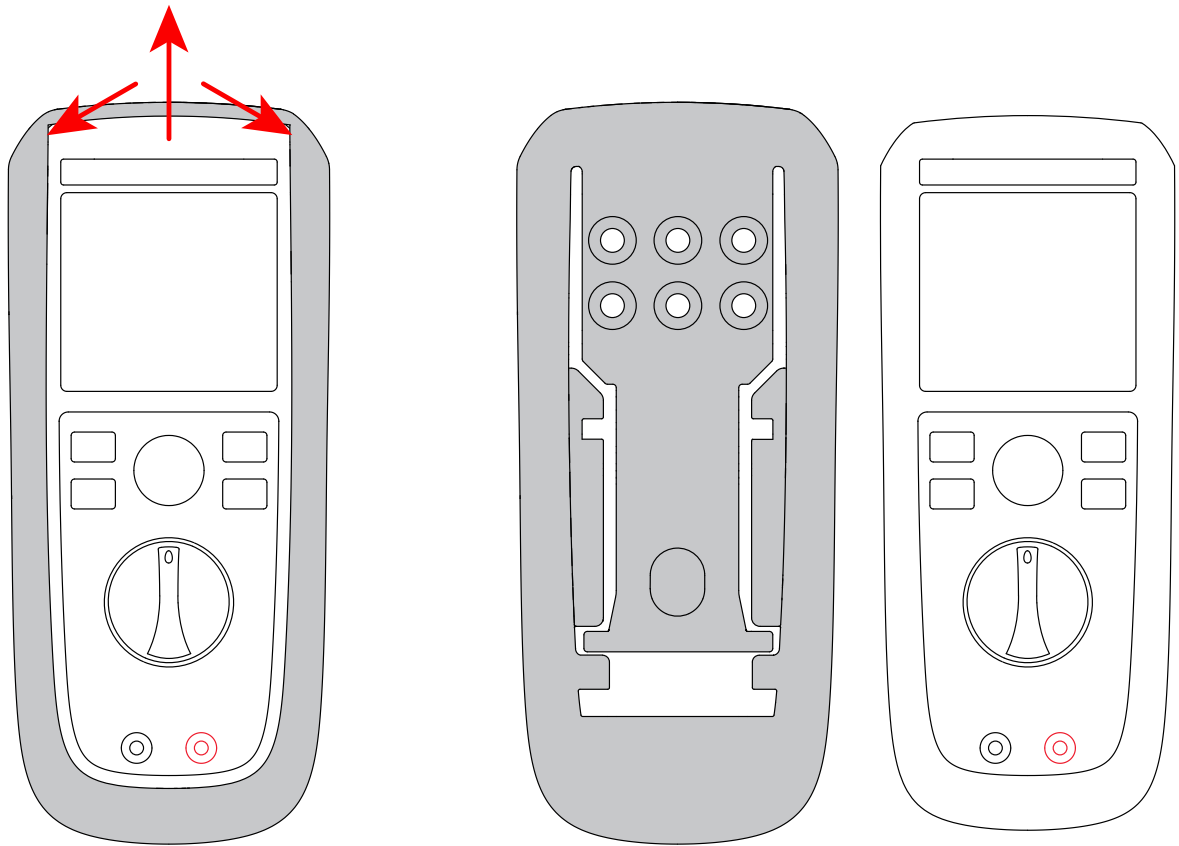

- Turn the instrument over.
- Use a screwdriver to unscrew the captive screw of the battery compartment cover, then remove the cover.
- Insert the 6 batteries provided, with the polarities as shown.
- Put the battery compartment cover back in place; make sure that it is completely and correctly closed.
- Screw the captive screw back in.
- Put the sheath back on the instrument, from the bottom.

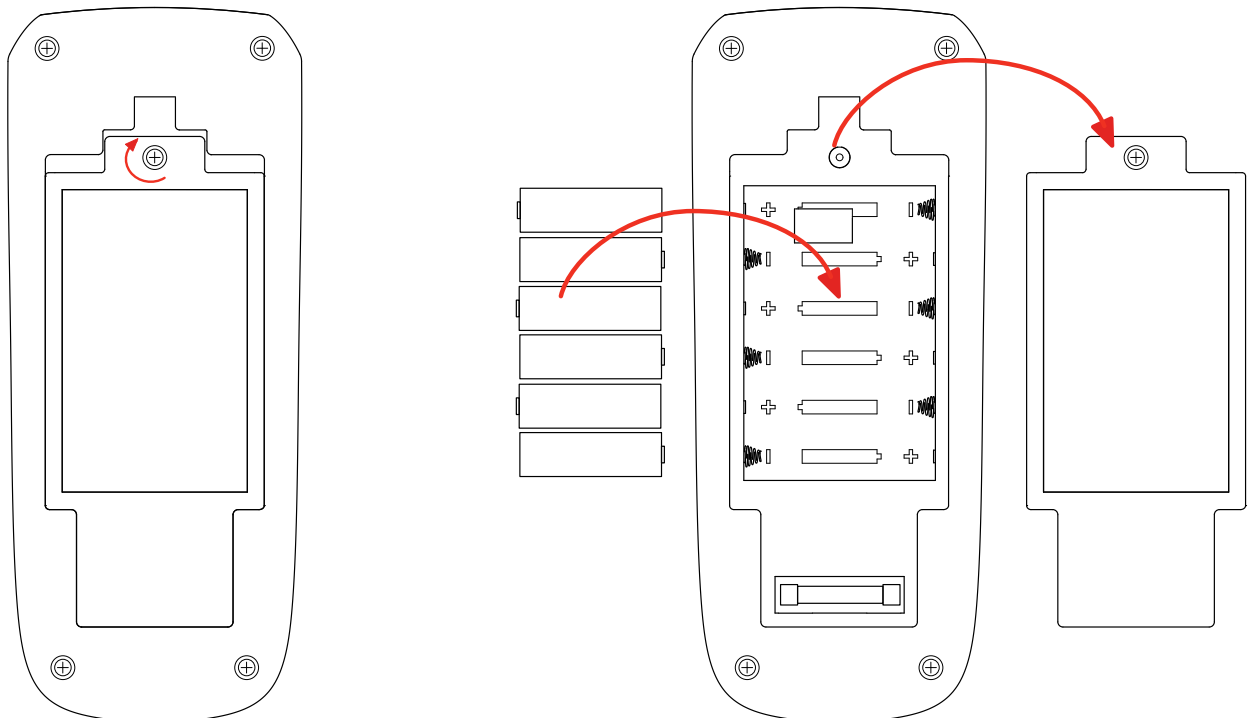

1.4. USING THE PROTECTIVE SHEATH

You can place your instrument upright on its back stand.

To do this, pull the back stand down, to free it from its slot, then fold it and insert the end in the other slot.

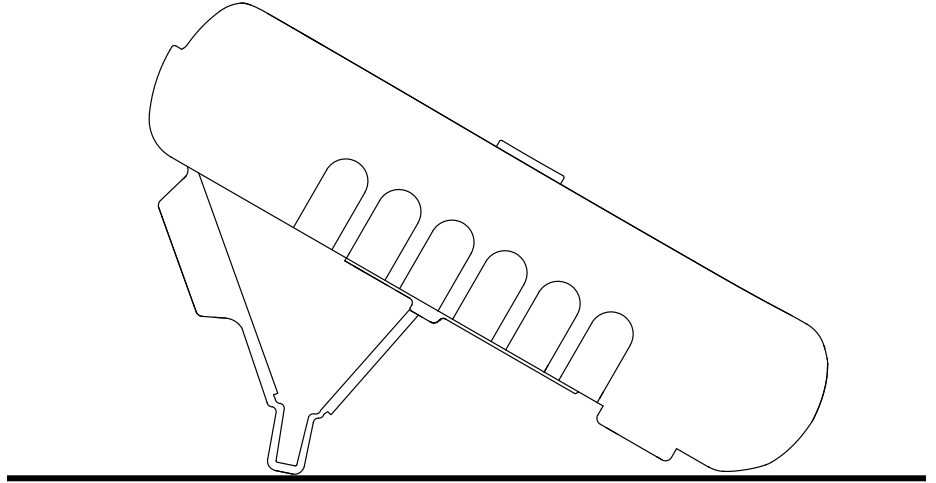
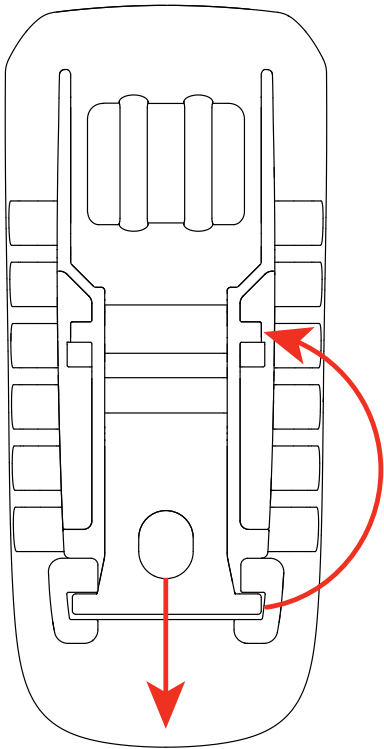

The stand can also be used to hook the instrument on a door.

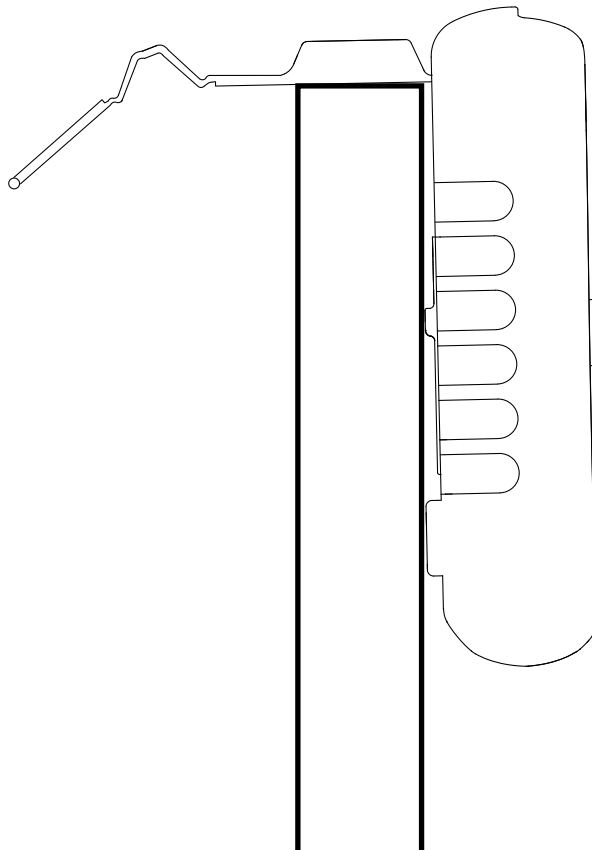

2. PRESENTATION OF THE INSTRUMENT

2.1. C.A 6528

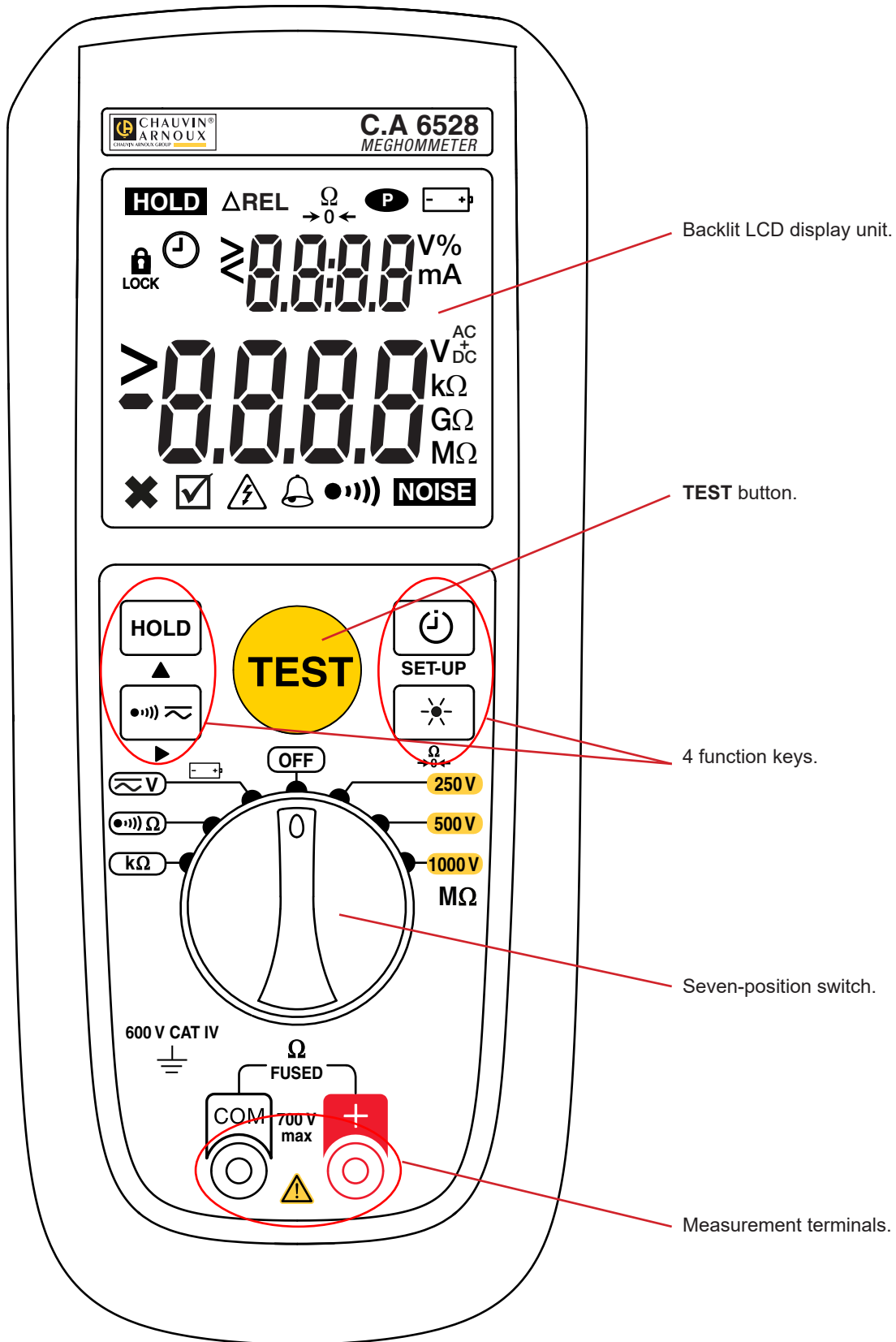

2.2. FUNCTIONS

The megohmmeter C.A 6528 is a portable measuring instrument, with LCD display. Powered by batteries.

This instrument is used to check the safety of electrical installations. It can be used to test a new installation before it is powered up, to check an existing installation, whether in operation or not, or to diagnose a malfunction in an installation.

The C.A 6528 is used to make:

- voltage measurements,
- insulation measurements at 250, 500, and 1000V,
- continuity measurements,
- resistance measurements.

The alarm function of the C.A 6528 makes it possible to check that the readings are OK rapidly, without looking at the display unit.

2.3. DISPLAY

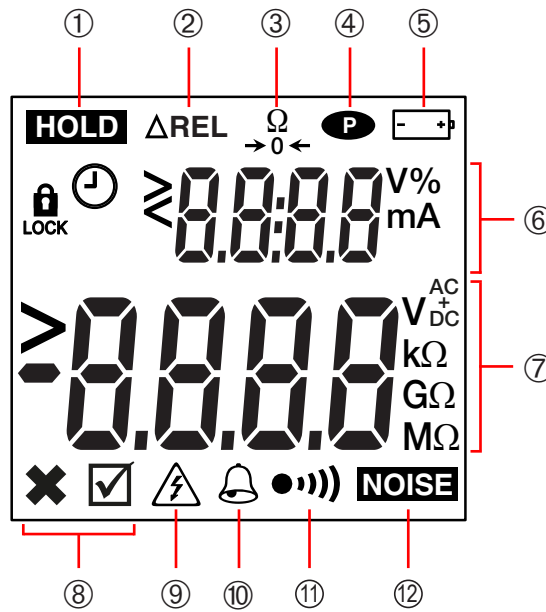

- ① Indicates that the measurement is frozen.
- ② Indicates that the DMR function (Differential Mode Resistance or relative mode) is active in a resistance measurement.
- ③ Indicates that the resistance of the leads is compensated in a continuity measurement.
- ④ Indicates that auto-off is deactivated.
- ⑤ Indicates the condition of the batteries.
- ⑥ Secondary display unit.
- ⑦ Main display unit.
- ⑧ Indicates whether the measurement is OK or not with respect to the alarm threshold.
- ⑨ Indicates the presence of a hazardous voltage on the terminals
- ⑩ Indicates that the alarm is active in an insulation or DMR measurement.
- ⑪ Indicates that the beep is activated.
- ⑫ Indicates a spurious voltage in a continuity or resistance measurement.

2.4. KEYS AND BUTTON







2.4.1. TEST BUTTON

Pressing the **TEST** button starts an insulation measurement.

It also serves to confirm a programmed threshold.

In resistance measurement, it is used to enter the DMR mode and record the reference measurement. And also to exit from the DMR mode.

2.4.2. FUNCTION KEYS

Key	Function
HOLD ▲	Pressing the key freezes or unfreezes the measurement. In SET-UP mode, the function of the key is ▲.
 ▶	In insulation measurement, pressing the key activates or deactivates the alarm. In continuity measurement, pressing the key activates or deactivates the alarm beep. In resistance measurement, pressing the key activates or deactivates the DMR alarm beep. In voltage measurement, the key is pressed to choose between AC+DC measurement or DC only. In the SET-UP mode, the function of the key is ▶.
 SET-UP	In insulation measurement, the TIMER key is used to select the  and  functions. In insulation measurement, a long press on the key sets the alarm threshold corresponding to the test voltage. In continuity measurement, a long press on the key serves to choose the alarm threshold. In resistance measurement, a long press on the key lets you set the threshold in %.
  → 0 ←	The key is pressed to switch the backlighting on or off. In continuity measurement, a long press lets you compensate the resistance of the measurement leads.

3. USE

3.1. CHECKING THE OPERATION OF THE INSTRUMENT

 Before making any use of the instrument, check that it is operating correctly.

- Make a voltage measurement on a known voltage. If the measurement is incorrect, do not use the instrument.
- In continuity measurement, short-circuit the leads. The reading must be close to zero. If not, either the leads are defective or the fuse must be replaced (see §5.3).

3.2. VOLTAGE MEASUREMENT

3.2.1. MAKING A MEASUREMENT

Set the switch to **V**. The instrument also makes voltage measurements in the **MΩ** settings.

Using the leads, connect the device to be tested to the terminals of the instrument.

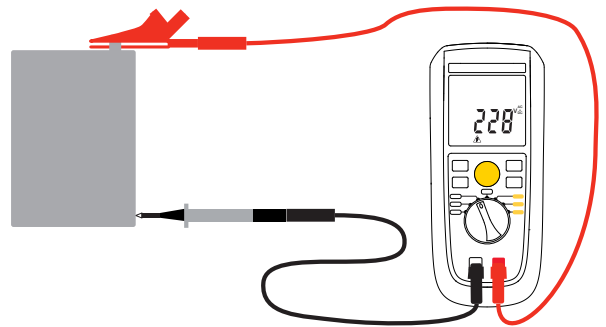
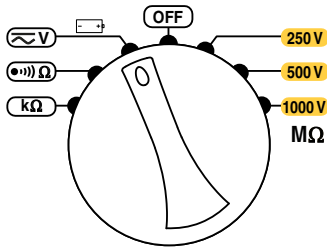

The instrument displays the AC+DC voltage. If it is >30V, the  symbol is displayed to warn the user that the voltage on the terminals is hazardous.

To know the value of the DC component of the voltage, press the  key.

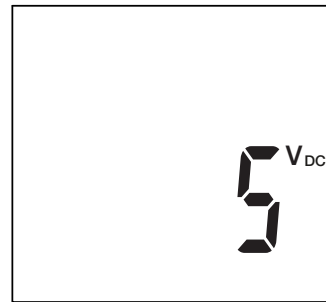
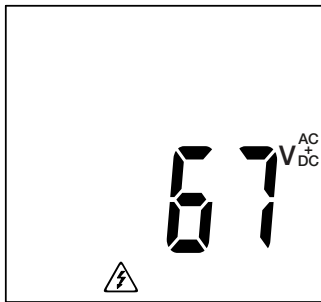

3.2.2. AC+DC MEASUREMENT

Why is it important to measure the AC+DC voltage?

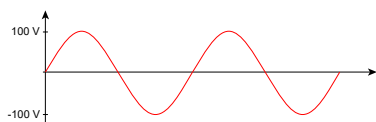

$V_{DC} = 0 \text{ V}$
 $V_{AC} = 100 \text{ V}$
 $V_{AC+DC} = 100 \text{ V}$

If the voltage is pure AC, the DC voltage reading is zero.

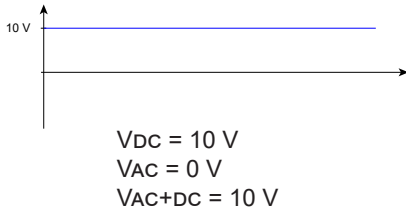

If the voltage is pure DC, the AC voltage reading is zero.

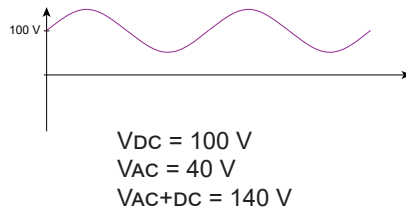

If the voltage is mixed (AC plus DC), as in the example opposite, a DC voltage with a ripple, the AC+DC measurement gives the true value; the AC measurement does not.



The AC+DC measurement yields better information as regards energy and electrical safety.

3.2.3. ERROR INDICATION

If the measurement departs from the measurement range, the instrument so reports by displaying **OL**.

3.2.4. BATTERY VOLTAGE

To check the battery voltage, press and hold the **TEST** key with the switch set to **V**.

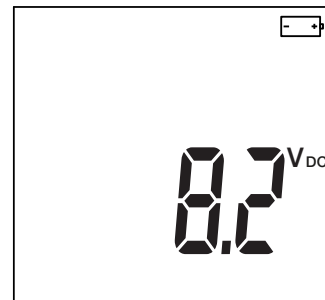
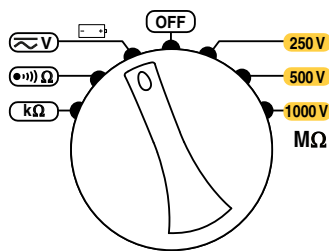

3.3. INSULATION RESISTANCE MEASUREMENT

3.3.1. DESCRIPTION OF THE MEASUREMENT PRINCIPLE

The device generates a DC test voltage between the **+** and **COM** terminals. This voltage depends on the resistance to be measured: it is between U_N and $1.25 U_N$ when $R \geq R_N = U_N / 1\text{mA}$, and is lower otherwise. The device measures the voltage and current present between the two terminals and from them deduces the value of $R=V/I$.

The **COM** terminal is the voltage reference point and the **+** terminal delivers a positive voltage.

3.3.2. MAKING A MEASUREMENT

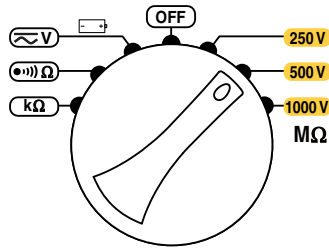

Set the switch to one of the **MΩ** positions.

The test voltage you should choose depends on the voltage of the installation to be tested. For example, for a network installation at 230 V, insulation measurements will be made at 500 V.

Use the leads to connect the object to be tested to the terminals of the instrument.

The object to be tested must not be live.

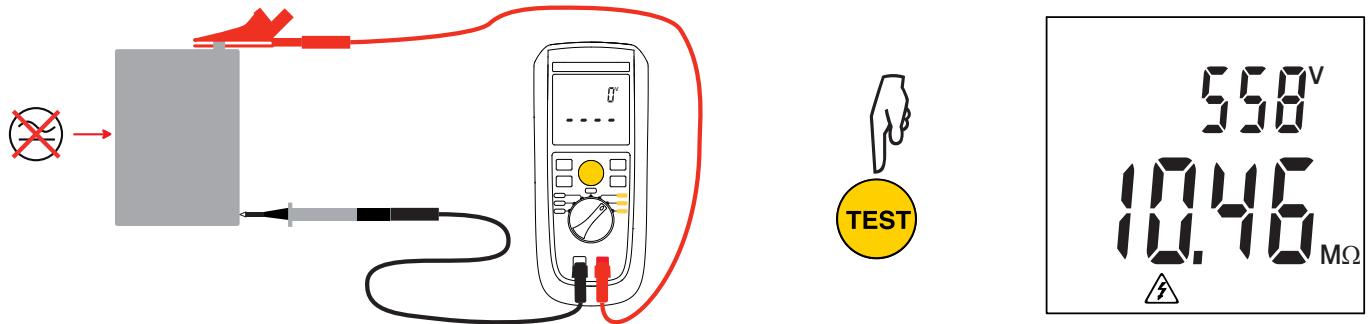

Press the **TEST** button and keep it pressed until the measurement is stable. The symbol indicates that the instrument is generating a hazardous voltage.

When you release the **TEST** button, the measurement is frozen and the instrument displays **HOLD**. You can see the voltage falling, which shows that the object tested is being discharged into the instrument. If the object tested is not capacitive, discharging is very rapid. When the voltage falls below 30V, the symbol disappears from the display.



Do not disconnect the instrument while the symbol is still displayed.



The measurement remains frozen until you press the **HOLD** key. The instrument then returns to voltage measurement. You can also start another measurement immediately by a long press on the **TEST** button.

3.3.3. TIMER KEY

In insulation measurement, the following functions are available:

1 st press	 Lock	This function is used to lock the TEST button so as not to have to keep it pressed during the insulation measurement.
2 nd press	 00:10	This function is used to make a measurement having a programmed duration (see §3.10).
3 rd press		Return to the initial screen.

3.3.4. OPERATION OF THE TEST BUTTON

The **TEST** button is pressed to make an insulation measurement. The test voltage is generated for as long as the press is maintained. When the button is released, the measurement stops.

In the **LOCK** mode, simply long-press the **TEST** button to start the measurement, then long-press again to stop it; there is no need to keep the button pressed. However, if you forget to stop the measurement, it will stop automatically after 40 minutes.

In the **⌚** mode, simply long-press the **TEST** button to start the measurement; it stops automatically at the end of the programmed duration.

3.3.5. ALARM



Before the insulation measurement, pressing the **•••••** key activates the alarm.

The alarm threshold is displayed, along with the **🔔** and **•••••** symbols.

Press the **TEST** key. If the measurement exceeds the threshold, the **☑** symbol is displayed.

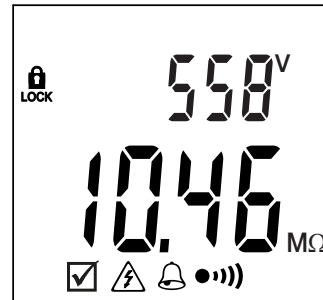
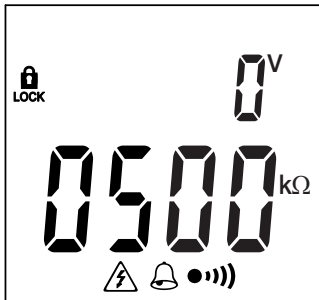

The alarm thresholds can be programmed (see §3.9). There is one for each test voltage.

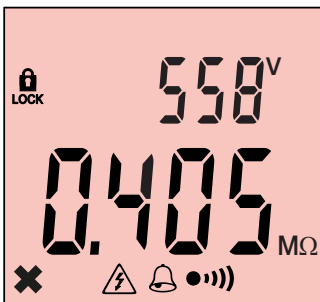

On the other hand, if the measurement is below the threshold, the instrument emits a continuous beep, the backlighting lights red, and the **✖** symbol is displayed.



A second press on the **•••••** key deactivates the alarm.

3.3.6. ERROR INDICATION

- If the measurement departs from the measurement range, the instrument so reports by displaying **LO** (if the insulation resistance is too low to allow generation of the voltage) or **>4200MΩ** (for a test voltage of 250 or 500V) or **>11.00GΩ** (for a test voltage of 1000V).
- If the object to be tested is at a hazardous voltage, the  symbol is displayed, the instrument emits a pulsed beep, and pressing the **TEST** button is impossible.
- If the instrument fails to generate a voltage, check the fuse (see §5.3).

3.4. CONTINUITY MEASUREMENT

3.4.1. DESCRIPTION OF THE MEASUREMENT PRINCIPLE

The instrument generates a 200mA direct current between the + and COM terminals. It then measures the voltage present between these two terminals and from it deduces the value of $R = V/I$.

3.4.2. MAKING A MEASUREMENT

To comply with the IEC 61557 standard, continuity measurements must be made with a positive current, then with a negative current. The 2 measurements must then be averaged. The reversal of the current serves to compensate for any residual electromotive forces and, more important, to check that the continuity is in fact duplex.

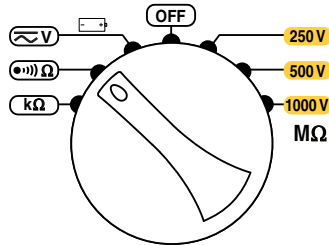

Set the switch to $\bullet\Omega$.

Use the leads to connect the object to be tested to the terminals of the instrument.

 The object to be tested must not be live.

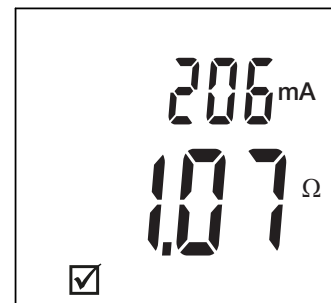
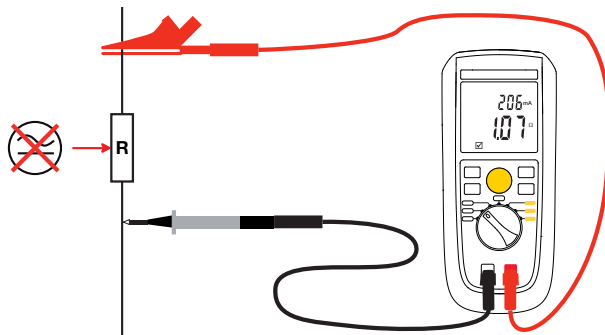

To make sure that there is no voltage, make a voltage measurement before the continuity measurement.

When the first measurement has been made, note the value and reverse the leads.

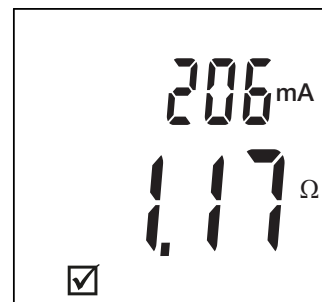
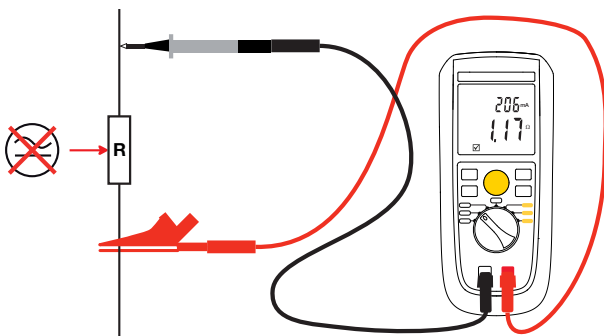

Note the second value and calculate the average.

 The measurement results can be thrown off by the impedances of circuits connected in parallel or by transient currents.

3.4.3. COMPENSATION OF THE MEASUREMENT LEADS

For best measurement accuracy, compensate the resistance of the measurement leads.

To do this, short-circuit the measurement leads. The instrument displays the resistance of the leads.

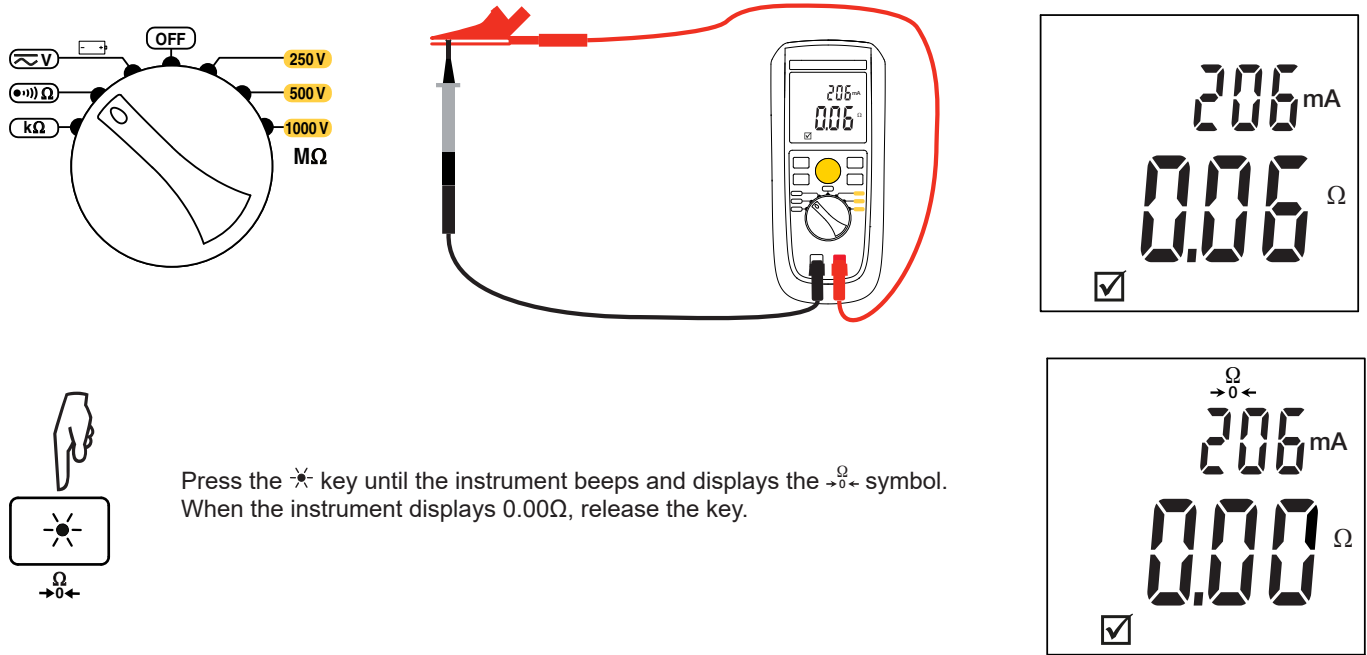

The leads are also compensated for resistance measurements. The compensation is retained even after the instrument is switched off.

If the resistance of the leads is $>5\Omega$, compensation is impossible.

i If you change the leads without redoing the compensation, the reading can become negative.

The backlighting then lights red and the \times symbol is displayed. Carry out a compensation with the new leads.

3.4.4. ELIMINATING THE COMPENSATION OF THE MEASUREMENT LEADS

To eliminate the compensation of the leads, leave the leads open and press the $\rightarrow 0 \leftarrow$ key until the instrument beeps and the $\rightarrow 0 \leftarrow$ symbol disappears.

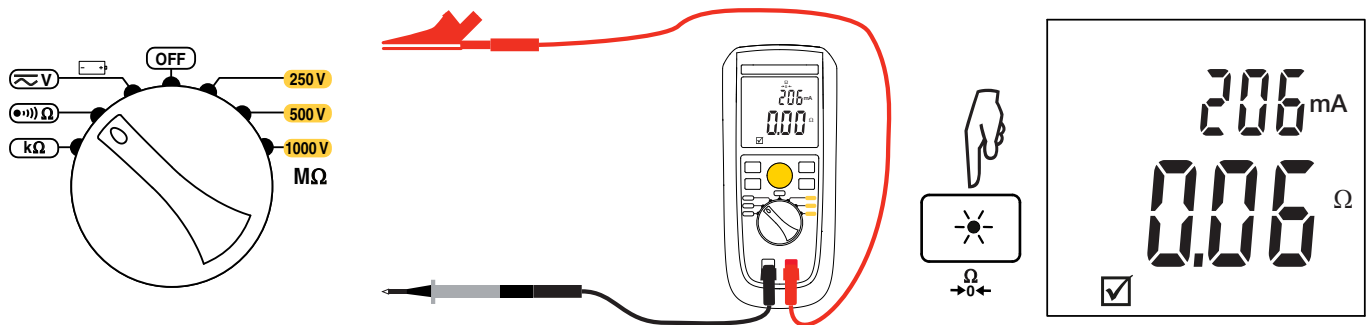

3.4.5. ALARM



The alarm is always active in continuity measurement.

The instrument gives you a choice of two alarm thresholds: 1Ω or 2Ω . See §3.9.

If the measurement is below the threshold, the symbol is displayed.

If the measurement exceeds the threshold, the backlighting lights red and the **X** symbol is displayed.



To activate the audible alarm signal, press the  key. The  symbol is displayed and the beep is emitted when the measurement is below the threshold. This lets you check that the continuity measurement is OK just by listening, without looking at the display unit.

3.4.6. ERROR INDICATION

- If the measurement departs from the measurement range, the instrument so reports by displaying **>42.00Ω**.
- When the measurement current is $<200\text{mA}$, the measurement made is still correct but is no longer compliant with the standard.
- If there is a voltage exceeding 0.4V on the object to be tested, the instrument displays **NOISE**.
- If the object to be tested is at a hazardous voltage, $>30\text{V}$, the  symbol is displayed and the instrument emits a pulsed beep.

3.5. RESISTANCE MEASUREMENT

3.5.1. DESCRIPTION OF THE MEASUREMENT PRINCIPLE

The device generates a DC voltage between the + and COM terminals. It then measures the voltage present between these two terminals and from it deduces the value of $R = V/I$.

3.5.2. MAKING A MEASUREMENT

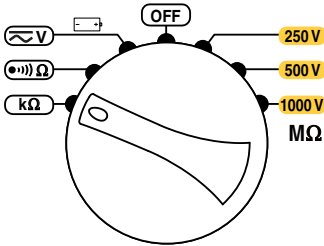

Set the switch to the kΩ position.

Use the leads to connect the object to be tested to the terminals of the instrument.

 The object to be tested must not be live.

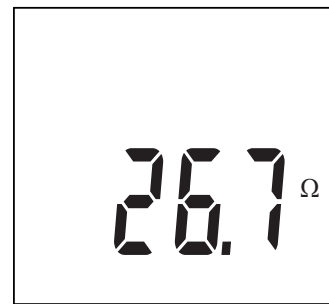
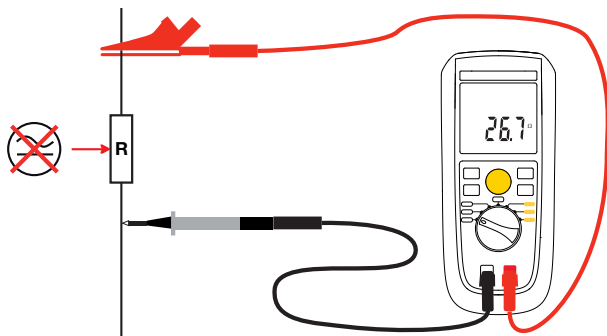

To make sure that there is no voltage, you can make a voltage measurement before the continuity measurement. Otherwise, the instrument will report the presence of a voltage if there is one.

If the leads have been compensated for continuity, this compensation will be used in resistance measurements..

3.5.3. DMR MODE

The DMR mode (Differential Mode Resistance), or relative mode, is for installers of in-floor heating. The purpose is to check that all the resistances of a given installation are the same to within a few percent (generally 5%).

- Start by setting the threshold in % (see §3.9).
- Make the first measurement and press the **TEST** button to record it. This will be the reference measurement.

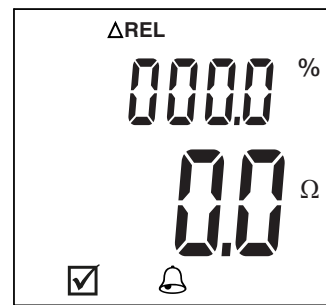

At each new measurement, the instrument indicates the difference between the new reading and the reference measurement, along with the difference in %.

If the difference is below the programmed threshold, the symbol is displayed.

If the difference exceeds the programmed threshold, the backlighting lights red and the ✘ symbol is displayed.

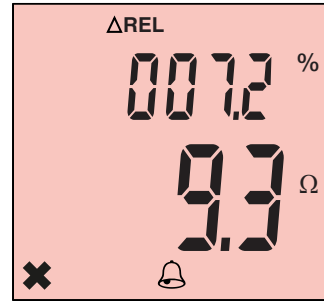
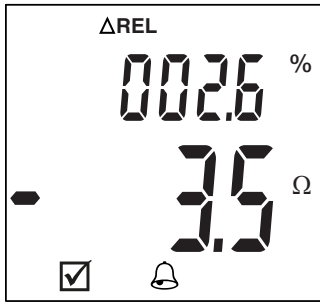

Pressing the  key activates the beep. When the difference exceeds the threshold, the instrument emits a continuous beep. This lets you check all of the resistances without looking at the display unit.



To exit from the DMR function, press the **TEST** button.

3.5.4. ERROR INDICATION

- If the measurement departs from the measurement range, the instrument so reports by displaying **>420.0kΩ**.
- If there is a voltage of more than 0.4V on the object to be tested, the instrument displays **NOISE**.
- If the object to be tested is at a hazardous voltage, >30V, the  symbol is displayed and the instrument emits a pulsed beep.

3.6. HOLD FUNCTION





Pressing the **HOLD** key freezes the display of the measurement. This can be done in all functions.

To unfreeze the display, press the **HOLD** key again.

3.7. BACKLIGHTING



Pressing the  key switches on the backlighting of the display unit.

To switch it off, press the  key again. Otherwise, it switches itself off after 2 minutes, unless you have deactivated auto-off (see §3.8).

3.8. SET-UP

To go to the set-up of the instrument, press the **TIMER** key while turning the switch from **OFF** to any other setting. When you hear the beep, release the **TIMER** key.

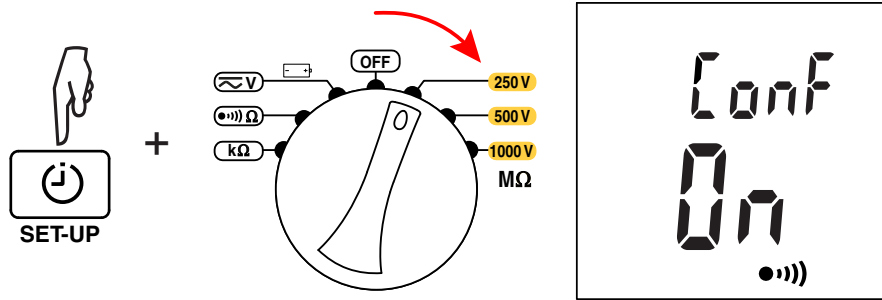

Then use the ▲ and ► keys to scroll and modify the parameters.

		<p>The beep is active.</p> <p>To deactivate it, press ►; the On changes to OFF.</p> <p>The next time the instrument is switched on, the alarm beep will be deactivated.</p>
1 st press on ▲		<p>Permanent mode is deactivated (or auto-off is activated).</p> <p>This means that after 10 minutes with no sign of the user's presence, the instrument switches to standby. Press the TEST button to wake the instrument.</p> <p>To deactivate auto-off, press the ► key; the OFF changes to On.</p> <p>The next time the instrument is switched on, auto-off will be deactivated and the P symbol will be displayed.</p>
2 nd press on ▲		<p>Automatic switching off of the backlighting is activated.</p> <p>This means that, when you light the backlighting, it is switched off after 2 minutes.</p> <p>If you want it to stay on at all times, press the ► key; the OFF changes to On.</p> <p>The next time the instrument is switched on, automatic switching off of the back-lighting will be deactivated.</p>
3 rd press on ▲		<p>Display of the version of the instrument's embedded software.</p>
4 th press on ▲		<p>Return to the first screen.</p>

Switch your instrument off by turning the switch to **OFF**.
All of the changes will be applied the next time the instrument is switched on.

3.9. ALARM FUNCTION

The instrument has 5 alarm thresholds:

Function	Default threshold	Programmable threshold
Insulation 250V	250kΩ	from 50kΩ to 3.999GΩ
Insulation 500V	500kΩ	from 100kΩ to 3.999GΩ
Insulation 1,000V	1,000MΩ	from 200kΩ to 9.99GΩ
Continuity	2Ω	1Ω or 2Ω
Resistance DMR	5%	from 0.1 to 399.9%

To program a threshold, set the switch to the desired function, press the  key and release it when the beep sounds. The instrument displays the current threshold with the first digit blinking.





Use the ▲ key to set the digit and the ► key to go to the next digit. When all 4 digits have been set, choose the unit. Confirm by pressing the **TEST** button.

3.10. PROGRAMMED DURATION

To program the duration of insulation measurements in the programmed duration mode :

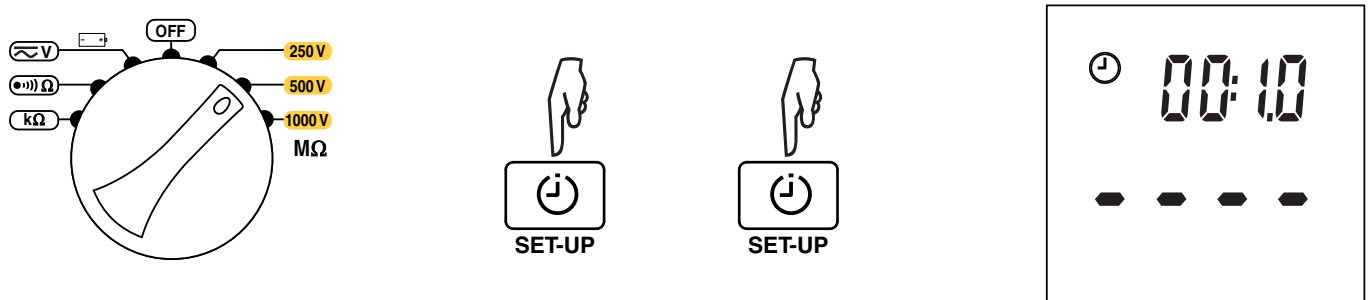
- Set the switch to any insulation setting.
- Press the  key twice. The instrument switches to the programmed duration mode.



- Long-press the  key; release it when the beep sounds. The instrument displays the active alarm threshold.
- Press the  key again. The instrument displays the programmed duration with the first digit blinking.

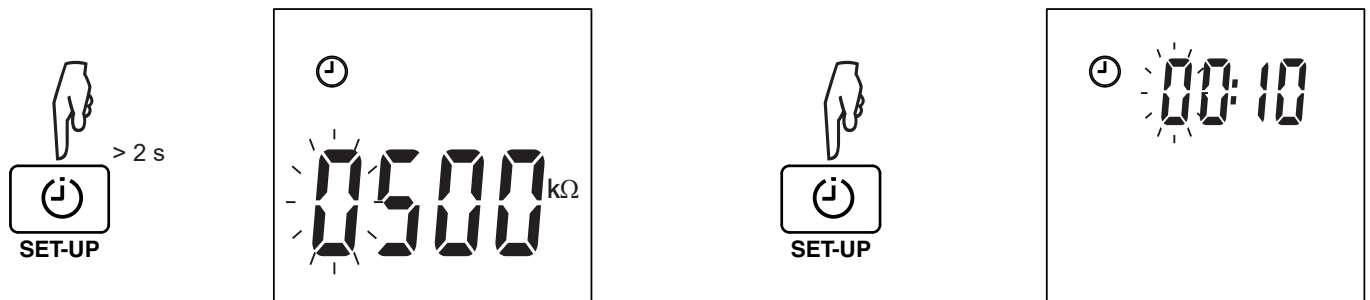

- Use the ▲ key to set the digit and the ► key to go to the next digit. Confirm by pressing the **TEST** button.

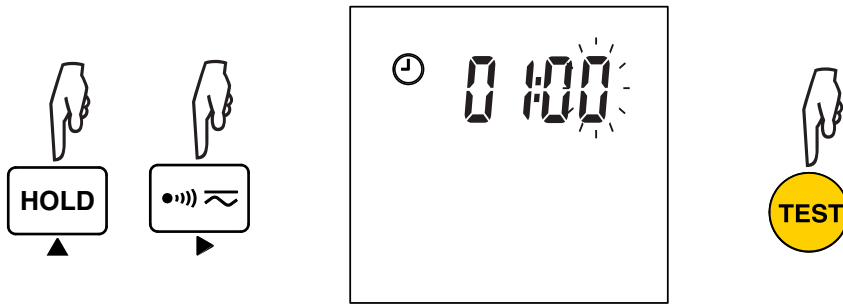

The duration can be programmed from 00:10 to 39:59 (from 10 seconds to 40 minutes).

3.11. AUTOMATIC STOP

After 10 minutes of operation with no sign of the user's presence (key press or rotation of the switch), the instrument switches to standby.

To exit from standby, press the **TEST** button.

Auto-off is disabled during insulation measurements in  **Lock** mode.

This auto-off can be deactivated (see §3.8).

4. TECHNICAL CHARACTERISTICS

4.1. GENERAL REFERENCE CONDITIONS

Quantity of influence	Reference values
Temperature	23 ±3°C
Relative humidity	45 to 75%RH
Supply voltage	8 to 9V
Warm-up time	5 minutes
Electric field	<0.1V/m
Magnetic field	<40A/m

The **intrinsic uncertainty** is the error specified for the reference conditions.

The **operating uncertainty** includes the intrinsic uncertainty plus the effects of variation of the quantities of influence (supply voltage, temperature, interference, etc.) as defined in standard IEC 61557.

The uncertainties are expressed in % of the reading (R) and in number of display points (pt):
 $\pm(a\% R + bpt)$

4.2. ELECTRICAL CHARACTERISTICS

4.2.1. VOLTAGE MEASUREMENTS

Particular reference conditions:

- Peak factor = $\sqrt{2}$ = 1,414 in AC (sinusoidal signal)
- AC component <0.1% in DC measurement
- DC component <0.1% in AC measurement

Voltage measurements

Specified measurement range	1-700 V _{AC+DC}	1-700 V _{DC}
Resolution	1V	1V
Intrinsic uncertainty	$\pm(1,2\% L + 1pt)$	$\pm(1\% L + 1pt)$
Input impedance	10M Ω	

4.2.2. CONTINUITY MEASUREMENTS

Particular reference conditions:

- Resistance of the leads: $\leq 0.01\Omega$ (compensated).
- External voltage in series: zero.
- Common mode voltage: zero.
- Inductance in series with the resistance: $\leq 1nH$.

The compensation of the leads is effective up to 5 Ω .
 The response time for threshold detection <300ms.

Specified measurement range	0.02-2.00 Ω	2.00-39.99 Ω
Resolution	0.01 Ω	0.01 Ω
Measurement current	$\geq 200mA$	between 100 and 200mA
Intrinsic uncertainty	$\pm(1.2\% R + 3pt)$	
No-load voltage	6 V _{DC} <U <9 V _{DC}	

The instrument is protected between the terminals by a fuse.

4.2.3. RESISTANCE MEASUREMENTS

Particular reference conditions:

Resistance of the leads: $\leq 0.1\Omega$ (compensated).
 External voltage in series: zero.
 Common mode voltage: zero.

Specified measurement range	1-399.9 Ω	360-3999 Ω	3.60-39.99k Ω	36.0-420.0k Ω
Resolution	0.1 Ω	1 Ω	10 Ω	100 Ω
Intrinsic uncertainty	$\pm(1.2\% L + 3pt)$			
No-load voltage	4.5V			

4.2.4. INSULATION RESISTANCE MEASUREMENTS

Particular reference conditions:

Capacitance in parallel: $<1nF$.
 External voltage in series: zero.
 Common mode voltage: zero.

Insulation resistance

Specified measurement range at 250V	0.050-3.999M Ω	3.60-39.99M Ω	36.0-399.9M Ω	360-4200M Ω	-
Specified measurement range at 500V	0.100-3.999M Ω	3.60-39.99M Ω	36.0-399.9M Ω	360-4200M Ω	-
Specified measurement range at 1000V	-	0.20-39.99M Ω	36.0-399.9M Ω	360-4200M Ω	3.60-11.00G Ω
Resolution	0.001M Ω	0.01M Ω	0.1M Ω	1M Ω	0.01G Ω
Intrinsic uncertainty	$\pm(1.5\% R + 10pt)$	$\pm(1.5\% R + 10pt)$	$\pm(1.5\% R + 10pt)$	$\pm(4\% L + 10pt)$ and $\pm(4\% L + 5pt)$ at 1000V	$\pm(10\% R + 10pt)$
No-load voltage	$\leq 1.25 \times U_N$				
Nominal current	$> 1mA$				
Short-circuit current	$<15mA$ peak-to-peak				

Typical test voltage vs load curve

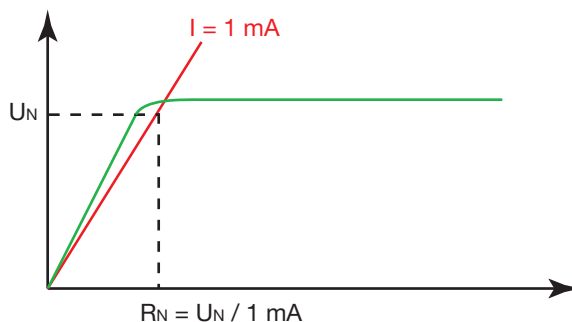

The voltage developed as a function of the resistance measured has the following form:
 The maximum load capacitance is 300nF, but the instrument operates correctly up to 2 μF .

The response time is $<2s$

4.2.5. TIMER

Specified range	0:10-39:59
Resolution	1s
Intrinsic uncertainty	$\pm 1s$

4.2.6. MESURES DE RESISTANCE

4.3. VARIATIONS IN THE RANGE OF USE

4.3.1. VOLTAGE MEASUREMENT

Quantities of influence	Limits of the range of use	Variation of the measurement	
		Typical	Maximum
Temperature	-10 to +50°C	1pt	±(0.3%L/10°C +1pt)
Relative humidity	20 to 80%HR	1pt	±(1%L +2pt)
Supply voltage	6.6 to 9.6V		±(0.1%L +2pt)
Frequency	30 to 440Hz	0.5dB	1dB
Peak factor	1 to 3 (up to 200V)	0%	1%
Series mode rejection at 50/60Hz AC and DC	0 to 1.000V	60dB	
Common mode rejection in AC 30-400 Hz	0 to 1.000 Vac	40dB	

4.3.2. INSULATION MEASUREMENT

Quantities of influence		Limits of the range of use	Variation of the measurement	
			Typical	Maximum
Temperature	R ≤400MΩ	-10 to +50°C	±1000 ppm L/°C	±2000 ppm L/°C
	R <10GΩ			±4000 ppm L/°C
Relative humidity		75 to 90%HR	±2%L	±5%L
		10 to 45%HR	±0.5%L	±3%L
Supply voltage		6.6 to 9.6V	±0.1%L	±1%L
50/60Hz AC voltage superposed on the test voltage (U _N)		0-10V		±(2%L +2pt)
		10-30V		±(5%L +2pt)
Capacitance in parallel on resistance to be measured		1 to 400nF @ I <1mA 400nF to 2μF @ I <1mA	±6%L	±10%L
Common mode rejection in AC 50/60 Hz		0-1000V	5 ppm L/V	15 ppm L/V
Rejection of the electric field in 50/60Hz AC		0-1000V/m	5 ppm L/V/m	15 ppm L/V/m

4.3.3. CONTINUITY MEASUREMENT

Quantities of influence	Limits of the range of use	Variation of the measurement	
		Typical	Maximum
Temperature	-10 to +50°C	±(0.5%L/10°C +2pt)	±(2%L/10°C +2pt)
Relative humidity	20 to 80%HR	1pt	±(2%L +2pt)
Supply voltage	6.6 to 9.6V		±(0.1%L +2pt)
50/60Hz AC voltage superposed on the test voltage	R <2Ω: 0.5 VAC R ≥ 2Ω: 0.4 VAC		±(5%L +10pt)
Common mode rejection in AC 50/60 Hz	0 to 1 000 Vac	50dB	40dB

4.3.4. RESISTANCE MEASUREMENT

Quantities of influence	Limits of the range of use	Variation of the measurement	
		Typical	Maximum
Temperature	-10 to +50°C		±(1%L/10°C +2pt)
Relative humidity	20 to 80%HR		±(3%L +2pt)
Supply voltage	6.6 to 9.6V		±(1%L +2pt)
50/60Hz AC voltage superposed on the test voltage	0-0.4 VAC		±(5%L +10pt)
Common mode rejection in AC 50/60 Hz	0 to 1.000 VAC	50dB	40dB

4.4. INTRINSIC UNCERTAINTY AND OPERATING UNCERTAINTY

The megohmmeters comply with standard IEC 61557, which requires that the operating uncertainty, called B, be less than 30%.

- In insulation, $B = \pm (|A| + 1,15 \sqrt{E_1^2 + E_2^2 + E_3^2})$
 with A=intrinsic uncertainty
 E_1 = influence of the reference position ±90°.
 E_2 = influence of the supply voltage within the limits indicated by the manufacturer.
 E_3 = influence of the temperature between 0 and 35°C.
- In continuity measurement, $B = \pm (|A| + 1,15 \sqrt{E_1^2 + E_2^2 + E_3^2})$

4.5. POWER SUPPLY

The instrument is powered by 6 LR6 or AA batteries.
 The range of operation is from 6.6 to 9.6V.
 The  symbol is displayed below 7.2V.

4.5.1. LIFE BETWEEN CHARGES

Typical life between charges of the device:

Function	Life between charges
Voltage	>200h
Continuity	>3,000 5-second measurements, with a 25s interval, at 1Ω 20,000 8-second measurements, with a 10s interval, at 1Ω
Insulation	1,000 5-second tests, with a 25s interval, at 1MΩ for $U_N = 1000V$
Instrument on standby	>2 months
Instrument off	>1 year

4.6. ENVIRONMENTAL CONDITIONS

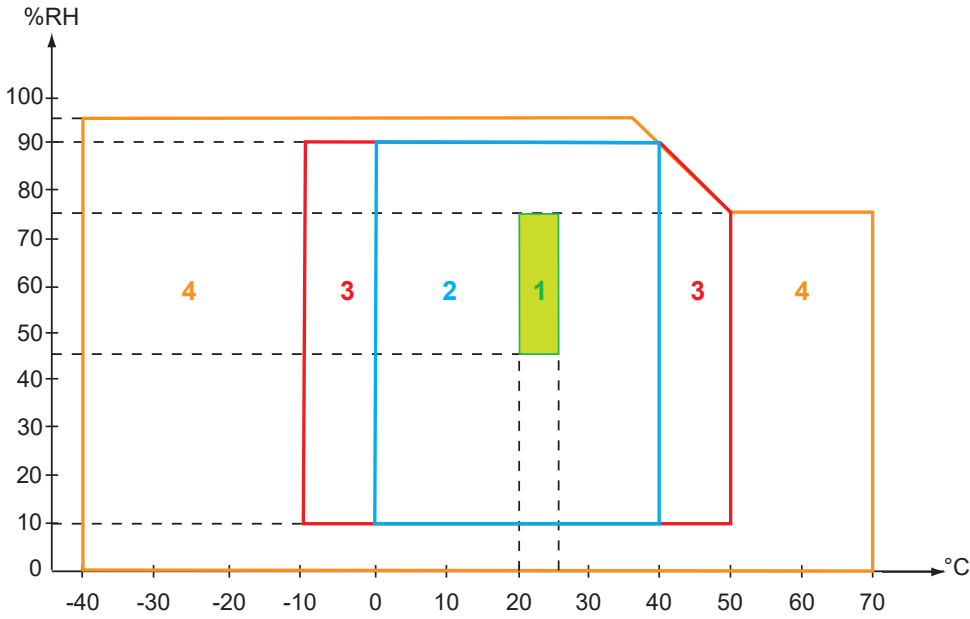

- 1 = Reference range, 20 to 26°C.
- 2 = Specified operating range, 0 to 40°C.
- 3 = Operating range, -10 to 50°C.
- 4 = Storage range (without batteries), -40 to +70°C.

Indoor use.
 Altitude <2.000m
 Pollution degree 2

The specified operating range corresponds to that of the operating uncertainty defined by the IEC 61557 standard.

4.7. MECHANICAL CHARACTERISTICS

Dimensions (L x W x H) 218x95x63mm
 Weight approximately 760g

Inrush protection IP40 per IEC 60529
 IK04 per IEC 50102

Drop test 2 meters per IEC 61010-1

4.8. COMPLIANCE WITH INTERNATIONAL STANDARDS

The device is compliant per IEC 61010-1, IEC 61010-2-030 and IEC 61010-2-034, 600V CAT IV.
 Assigned characteristics: measurement category IV, 600 V with respect to earth.

The device is protected by double or reinforced insulation.

The device is compliant per IEC 61557, parts 1, 2, 4 and 10.

4.9. ELECTROMAGNETIC COMPATIBILITY (CEM)

The instrument is compliant with standard IEC 61326-1.

5. MAINTENANCE



Except for the batteries and the fuse, the instrument contains no parts that can be replaced by personnel who have not been specially trained and accredited. Any unauthorized repair or replacement of a part by an “equivalent” may gravely impair safety.

5.1. CLEANING

Disconnect the unit completely and turn the rotary switch to OFF.

Use a soft cloth, dampened with soapy water. Rinse with a damp cloth and dry rapidly with a dry cloth or forced air. Do not use alcohol, solvents, or hydrocarbons.

5.2. REPLACING THE BATTERIES

When the  symbol starts blinking on the display unit, the batteries must all be replaced.

- Disconnect everything connected to the instrument and switch it off.
- Follow the instructions of §1.3.



Spent primary and storage batteries must not be treated as ordinary household waste. Take them to the appropriate collection point for recycling.

5.3. REPLACING THE FUSE

To check the fuse, short-circuit the continuity measurement terminals.

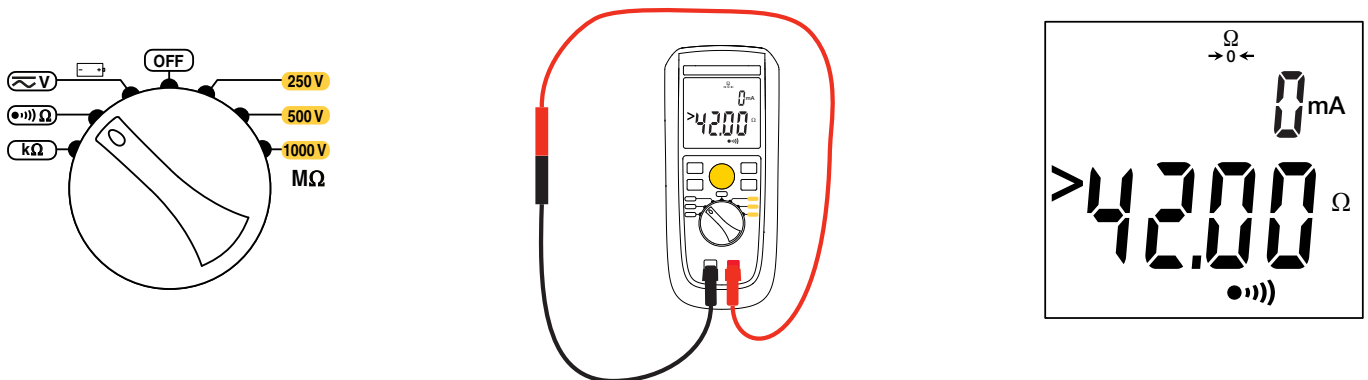

If the display unit indicates **>42.00Ω**, the fuse has blown and must be replaced.

- Disconnect everything connected to the instrument and switch it off.
- Remove the protective sheath as explained in §1.3.
- Then withdraw the case from the sheath.
- Turn the instrument over.
- Use a screwdriver to unscrew the captive screw of the battery compartment cover, then remove the cover.
- Remove the fuse and replace it with the exact type of fuse indicated on the label of the instrument.
: F 200mA 1000V 10kA



To keep the instrument safe, replace the blown fuse only with a fuse having exactly the same characteristics.

- Put the battery compartment cover back in place; make sure that it is completely and correctly closed.
- Screw the captive screw back in.
- Put the sheath back on the instrument, from the bottom

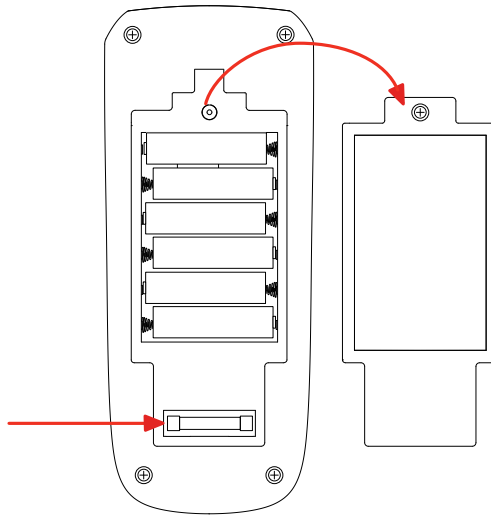

5.4. CALIBRATING THE INSTRUMENT

This must be done by qualified personnel. We recommend doing it once a year.

5.4.1. EQUIPMENT NECESSARY

- An ammeter (mA and μ A) accurate to 0.5% or better
- An 0.1 to 1000V voltage calibrator accurate to 0.1% or better
- One or more resistance boxes with the values:
 - 40 Ω , 4k Ω , 40k Ω , 180k Ω , 300k Ω , 400k Ω , 1.5M Ω with an accuracy of 0.2%,
 - 7M Ω , 40M Ω , 300M Ω , 1G Ω , 1.5G Ω , 3G Ω with an accuracy of 1%.

5.4.2. CALIBRATION PROCEDURE

To enter the adjustment mode, set the switch to **V** and press the 4 function keys simultaneously until the instrument beeps. Release the keys. The instrument displays **CA.1**, the first of the eight steps of the adjustment.

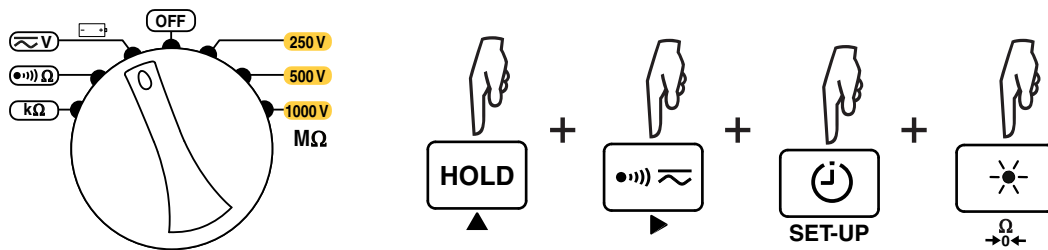

At each step, press the **TEST** key. The instrument performs the adjustment and displays the result (**PASS** or **FAIL**). Press the **▶** key to go to the next step or **▲** to return to the previous step.

CA.1-Adjustment of the voltage offset

Switch set to **V**

Short-circuit the terminals

- 6
- 100
- 500
- 1000

Disconnect the terminals

CA.2-Adjustment of the voltage gain

Switch set to V

Use the calibrator to generate the following DC voltages:

- 6 Calibrator set to 6.00 V_{DC}
- 100 Calibrator set to 100.00 V_{DC}
- 500 Calibrator set to 500.00 V_{DC}
- 1000 Calibrator set to 1000.00 V_{DC}

Disconnect the calibrator

CA.3-Adjustment of the offset for continuity and resistance

Switch set to Ω



Terminals not connected

- OHM1
- OHM2
- OHM3
- OHM4

CA.4-Adjustment of the current generated for continuity and resistance

Switch set to kΩ

Connect the ammeter to the terminals

Use the  and  keys to set the current to the value indicated by the ammeter.

- OHM1 ammeter set to the mA range
- OHM2 ammeter set to the mA range
- OHM3 ammeter set to the μA range
- OHM4 ammeter set to the μA range

Disconnect the ammeter

CA.5-Adjustment of the ground resistor for continuity and resistance measurements

Switch set to kΩ

Short-circuit the terminals

- OHM1
- OHM2
- OHM3
- OHM4

Disconnect the terminals

CA.6-Adjustment of the gain for continuity and resistance measurements

Switch set to kΩ

Connect the resistance box to the terminals

- OHM1 40Ω
- OHM2 4kΩ
- OHM3 40kΩ
- OHM4 400kΩ

Disconnect the terminals

CA.7-Adjustment of the offset for insulation measurements

Switch set to MΩ-250V

- A0 Terminals not connected
- A1 Terminals not connected
- A2 Terminals not connected
- A3 Terminals not connected
- A4 Terminals not connected
- A5 Connect the resistance box to the terminals, value 1GΩ
- A6 Connect the resistance box to the terminals, value 3GΩ

CA.8-Adjustment of the gain for insulation measurements

Switch set to MΩ-250V

- Connect the resistance box to the terminals
- A0 80kΩ
- A1 300kΩ
- A2 1,5MΩ
- A3 7MΩ
- A4 40MΩ
- A5 300MΩ
- A6 1,5GΩ

Disconnect the resistance box.

Switch the instrument off by setting the switch to **OFF**.
Your instrument is now adjusted.

5.4.3. CHECKING THE INSTRUMENT

To check that the adjustment is correct, check the following measurement points:

- Voltage 230V_{DC}
- Voltage 230V_{AC}
- Resistance 10Ω
- Resistance 100Ω
- Resistance 1kΩ
- Resistance 10kΩ
- Resistance 100kΩ
- Insulation 10MΩ at 1000V
- Insulation 100MΩ at 1000V
- Insulation 1GΩ at 1000V
- Insulation 10GΩ at 1000V

Your instrument is now ready to be used.

6. WARRANTY

Except as otherwise stated, our warranty is valid for **24 months** starting from the date on which the equipment was sold. Extract from our General Conditions of Sale, provided on request.

The warranty does not apply in the following cases:

- Inappropriate use of the equipment or use with incompatible equipment.
- Modifications made to the equipment without the explicit permission of the manufacturer's technical staff.
- Work done on the device by a person not approved by the manufacturer.
- Adaptation to a particular application not anticipated in the definition of the equipment or not indicated in the user's manual.
- Damage caused by shocks, falls, or floods.

FRANCE

Chauvin Arnoux Group

190, rue Championnet

75876 PARIS Cedex 18

Tél : +33 1 44 85 44 85

Fax : +33 1 46 27 73 89

info@chauvin-arnoux.com

www.chauvin-arnoux.com

INTERNATIONAL

Chauvin Arnoux Group

Tél : +33 1 44 85 44 38

Fax : +33 1 46 27 95 69

Our international contacts

www.chauvin-arnoux.com/contacts

