



Safe Gates

**Regulations overview
Safety for gates and doors
Notice on the EN 12453
Certification**

Edition 2018

Notes for the use of this guide – Safe gates

The technical information contained in this guide have been drafted for informational purposes only. Microtronics S.r.l is not to be held responsible for potential damages to persons and/or things that may result directly or indirectly from the practical application of wrong or non-corresponding information.

It is expressly forbidden the reproduction, even if partial, of what is contained in the following pages, unless prior written authorisation by Microtronics S.r.l – Copyright 2006 – 2018

TOPICS COVERED

■ Overview on regulations and European Directives	Page 1
■ Directives and regulations on automatic gates and doors	Page 2
■ Requirements and responsibilities – Do not get lost in the deep waters of regulations	Page 3
■ Procedure for the installation and certification of gates and doors	Page 4
■ Realisation of the Technical File	Page 5
■ Maintenance register – Facsimile	Page 7
■ Declaration of CE conformity – Facsimile	Page 8
■ CE marking – Conclusions	Page 9
■ Risk assessment – In-depth analysis	Page 10
■ Simplified risk assessment form – Sliding gate	Page 11
■ Kinds of automatic gates and doors	Page 14

THE EUROPEAN REGULATIONS

Automatic gates and doors are regulated by the Machine Directive; during the last 20 years there has been a gradually updating of the regulations that **control the essential safety requirements of the products**. Here is an updated overview:

THE REGULATIONS are European laws, that once they have been transposed by the single countries, they become national laws.

THE COMPLIANCE of a product with a Directive is declared when a product respects the essentials requirements described in the Directive.

THE CE MARKING of a product is subject to compliance with all the applicable Directives.

THE TECHNICAL REGULATIONS define the minimum safety requirements and the construction criteria imposed by the Directives.

The obligation of the CE marking implies that the builder assumes the responsibility and declares the compliance of the product with the European Directives. In the case of industrial, commercial and garage gates and doors, the general regulation of reference is the **EN 13241-1**, that properly respected, permits the builder to benefit from the presumption of compliance with the following regulations:

CONSTRUCTION PRODUCTS REGULATION CPR 305/2011 ex89/106/EEC

The Construction Products Regulation **CPR** n° 305/2011 (that has substituted the Directive 89/106/EEC on the construction products CPD) lists the harmonized conditions for the correct sale of construction products. The Directive establishes the concepts and the application of the CE marking, essential condition for the companies that have to adopt the simplified procedure with consequent reduction of the costs. Recently has been added also the Declaration of Performance **DoP**, a particular “self-declaration” of the builder, who assumes the responsibility for the conformity of the construction product.

MACHINERY DIRECTIVE 2006/42/EC – Power operated gates and doors

The Machinery Directive **2006/42/EC** requires that automatic gates and doors **must be considered like actual Machineries**, and as such they must comply with specific safety standards. This applies for new installations, whereas the already present installations must be adjusted (if necessary). Recently has been added and updated also the definition of the “**Partly Completed Machinery**”.

DEFINITION OF MACHINERY: group of stationary and moveable parts (at least one moveable), connect and/or assembled one another (also sturdily) and actioned by electrical systems or by power actuators with the aim of perform well determined applications (movements, transformations, generations).

DEFINITION OF PARTLY COMPLETED MACHINERY: group of parts and/or systems which cannot perform a specific application; a partly completed machinery has an autonomy function and it is designed to be part of a machinery or of a bigger plant.

ELECTROMAGNETIC CONFORMITY DIRECTIVE EMC 2014/30/UE – Motorized gates and doors

The Electromagnetic Conformity Directive EMC requires that the electromagnetic interferences created by the electronic equipment must be limited to not interfere with other equipment (that should themselves have an adequate level of immunity against the electromagnetic interferences).

LISTS OF THE REGULATIONS GOVERNING THE INDUSTRY OF AUTOMATIC GATES AND DOORS

The former group (in blue) regards mainly the installation, maintenance and certification, whereas the latter's (in orange and grey) are to be used mainly from the builder.

EN 13241:2016	Support regulations for industrial, commercial and garage doors and gates (CE conformity)
EN 12453:2017	Safety in use of powered gates and doors – Requirements and test methods (completes the ex EN12445)
EN 16005:2013	Pedestrian power operated doors – Requirements and test methods
EN 60335-2-95:2015	Single residential garage doors with vertical moving
EN 12978:2009	Safety devices for power operated doors and gates – Requirements and test methods
EN 12489:2002	Requirements of resistance to water penetration of manually actioned doors, gates and barriers
EN 12604:2017	Mechanical aspects of manually actioned doors, gates and barriers
EN 12605:2001	Test methods of manually actioned doors, gates and barriers
EN 12653:2008	Installation and use of doors, gates and barriers
EN 12433-1	Terminology - Types of doors
EN 12433-2	Terminology - Parts of doors
EN 12444	Resistance to wind load - Testing and calculation
EN 12427	Air permeability - Test method

FULFILLMENTS FOR THE INSTALLER OF AUTOMATIC GATES AND DOORS

The Machinery Directive 2006/42/EC transposed to all intents and purposes by all the countries members of the European Union, is today the reference point for the **obligations of making the machineries safe**. So, let's start from this important extract of the text of the Directive:

...the responsibility of the CE marking lies with the installer who has assembled the automation in place, creating a machinery that is one of a kind and that differentiates itself from the serial products for several constructive, structural and environmental aspects....

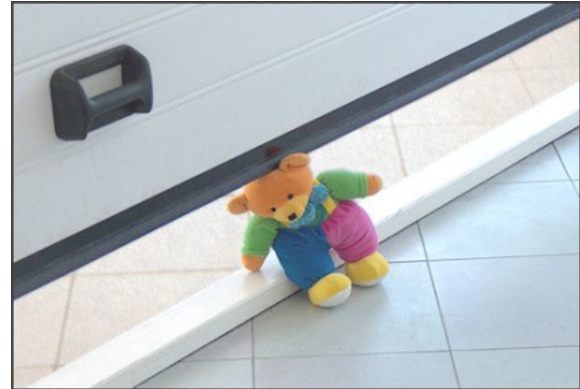

“

... clearly, the responsibility of potential damages to persons and/or things caused by the gate itself, lies directly with the final installer, because he has built the machinery, assembling ex-novo various electromechanical elements (engine, gate, warning and protection devices, etc.) in a final configuration that is never a serial product, but it is every time a new mac ...

”

DO NOT GET LOST IN THE DEEP WATERS OF REGULATIONS – HOW TO CERTIFY A “SAFE GATE/DOOR”

To obtain the presumption of conformity with the Machinery Directive, and so the CE marking, the professional who installs an automatic gate or door must, make reference to the harmonized regulation **EN 12453** that describes the construction requirements of the door and the tests that must be carried out in situ to certify its operating safety.

Among the obligations of the installer there is the one of compile the Technical File of the machinery, that contains the verification of the Essential Requirements, the risk assessment and the reports of the tests made in situ to check the operation of the safety devices; first of all, the system of limitation of the operating forces, by means of the specific measurement equipment required by the EN12453 standard.

In the following paragraphs will be analysed in detail the passages that are useful for the installer, from the certification of the automation to the creation of the maintenance register; it is a general procedure useful for all kinds of automatic gates and doors (see on page 14, kind of automatic gates and doors).

Specific guides on regulations can be downloaded from Microtronics' website (www.microtronics.it)

PROCEDURE FOR THE INSTALLATION AND CERTIFICATION OF AUTOMATIC GATES AND DOORS

- **Works execution in accordance with best practice**
 - Issue of the Declaration of Conformity
- **Realisation of the Technical File**
 - Sketch of the overall door/gate
 - Schema of the electrical connections and of the control circuits
 - Risk assessment with adopted solutions
 - Impact force measurements with corresponding print report
 - Declaration of Conformity of every single component
 - Instructions for use and general safety warnings
 - Maintenance register
 - Compilation and print of the Declaration of CE Conformity
- **Application of the plate with the CE marking**



“

It is important to underline that the application of the regulations should not be considered as a heavy bureaucratic burden, but as an opportunity to promote and **requalify the work of the installer of automatic gates and doors**; not only in terms of improvement of the quality of the service provided, but also with a view to a new big potential market, that is the **making safe**, obligatory also for all the pre-existing automatic gates and doors.

”

Below there is the detailed procedure:

WORKS EXECUTION IN ACCORDANCE WITH BEST PRACTICE

Normally the Declaration of Conformity is issued by the installer or by an electrician that is authorised to issue certificates. After having create a plant in accordance with best practice, it is necessary to certify the work with the specific form (see example next).

Together with the Declaration of Conformity is compulsory to attach at least the following documents:

- Project of the electric plant (if compulsory)
- Report with the materials used
- Schema of the created plant
- Copy of the certificate of the recognition of the technical-professional qualifications

**DICHIARAZIONE DI CONFORMITA' DELL'IMPIANTO
ALLA REGOLA DELL'ARTE
Rilasciata al committente dall'impresa installatrice**
(Art. 7, comma 1, D.M. 22 gennaio 2008, n. 37)

Il sottoscritto
titolare o legale rappresentante dell'impresa (ragione sociale)
operante nel settore con sede in via
n comune (prov) tel.
part. IVA

iscritta nel registro delle imprese (d.P.R. 7/12/1995, n. 581)
della Camera C.I.A.A. di n.

iscritta all'albo Provinciale delle imprese artigiane (l. 8/8/1985, n. 443) di
n esecutrice dell'impianto (descrizione schematica)

inteso come:
 nuovo impianto trasformazione ampliamento manutenzione straordinaria
 altro (1)

REALISATION OF THE TECHNICAL FILE

The Technical File includes **all the necessary documentation** for the certification of the automatic gate/door (e.g. electrical schemes, drawings, CE declaration, risk assessment, tests reports, etc.). The Technical File must be kept by the installer/builder for at least 10 years. (N.B it must be available for the competent authorities).

■ Sketch of the overall door/gate

This document could be included in the initial Project; however, it is possible to realise it with specific software or it could be also hand drawn in a simple squared paper.

■ Schema of the electrical connections and of the control circuits

Also this documentation could be already represented in the Project or be in the last pages of the user manual, or it could be provided by the manufacturer of the automation.

■ Risk assessment with adopted solutions

The risk assessment deals with the main safety problems related to the mechanical devices of the automation in movement. The impact/crush force produced by the electric engine is potentially dangerous for people or thing that are in the affected area.

In this regard, the regulation **EN12453:2017** “*Industrial, commercial and garage gates and doors – Safety in use of power operated doors. Requirements and test methods*” describes in detail all the possible situations of injury that must be taken in account for the adoption of the appropriate preventive measures: it goes from the already mentioned risk of impact/crush, but also to the risks of: dragging, shearing, hooking, etc... up to the problems that may arise when the electrical grid shuts down or when this last should return unexpectedly.

The regulation suggests the most suitable measures to make the door/gate safe, such as for example, the implementation of safety distances, the installation of protective barriers, the elimination of mechanical parts that are dangerously protruding and the adoption of automatic systems for the limitation of the forces.

N.B. In the paragraph **In-depth Risks Assessment** there is the concrete example of a classical **sliding gate**; for all the other kinds of gates and doors it is possible to download the specific guides from Microtronics' website.

■ Impact force measurements and corresponding print report

The impact forces (related to the main edge of the gate/door) have to be measured with the specific instrument (see Microtronics' **BlueForce Smart**), described in detail in the regulation EN12453. The instrument must have specific (mechanical and constructive) characteristics and a well determined precision, because the tests must give concrete, reliable and reproducible results.

For every kind of automatic gate/door must be carried out a certain number of tests at determined distances and positions. BlueForce Smart, thanks to its advanced software and to the free **App** for mobile devices, allows to have close at hand all the specific points and distances that are listed in the regulation EN 12453.

■ Declarations of Conformity of the single components

Often the automation in its complex is composed of more electrical or electromechanical parts assembled together. If the parts come from different manufacturers, it will be necessary to give the appropriate documentation (CE Declaration, manuals etc.) and also the **Declaration of Incorporation**, in the case there is an activation/actualization system considered a **partly completed machinery** (see on page 2 of the Directive 2006/42/CE).

■ Instructions for use and general safety warning

Normally the instructions for use (that can include also electrical schemas, CE declarations, mechanical representations etc.) are provided by the manufacturer. The instructions have all the necessary information for the user to utilize properly the automatic gate/door and they must include also the **modalities of maintenance** and the indications of the **risks and of the safety**.

■ Maintenance Register

The maintenance is of the **utmost importance** for the proper functioning of the automatic gate/door. In case the automatic door/gate is installed for a private user, therefore with poor flow of persons or things, it is possible to follow the indication of maintenance written in the instructions for use; however, at customer's request it is possible to integrate an actual maintenance register. The power operated doors/gates installed in areas with "high density of pedestrian crossing" (public places, companies, hospitals) require **necessarily the Maintenance Register** that must contain clearly these information:

- Customer data, technical data of the door/gate
- Indication of the date of first installation (or following maintenance)
- List of the controls/operations that must be done
- Space for the description of the activities of maintenance/repair
- Space for the description of the residual risks and of the foreseeable misuse

Please note that the Maintenance Register must be kept by the user and it must be available in the case of inspections by the authorized agencies or by the competent authorities.

The most important operations related to the maintenance register are:

- The tests of the "mechanical" and "electrical" safety requirements (see details in the paragraph "Risks assessment")
- The observance of the impact force limits and corresponding tests with the specific instrument described in the En12453
- The operation of the safety devices of the "D" and "E" types (see details in the paragraph "Risk assessment")

Note: according to the latest safety regulations, the regular maintenance of machines, plants and equipment is compulsory; for this reason, it could be necessary a Maintenance Contract, drawn to safeguard user and installer and the responsibility between the parties.

With the updating of the Directive **99/44/EC** have been put in practice the rules about the relationships seller-customer. The automatic gate/door is considered as a consumer good and thus the installer must remember also the duration of the warranty period and the potential substitution of defective components.

Follows facsimile Maintenance Register.



REGISTRO DI MANUTENZIONE

Il presente registro deve essere reso disponibile alle autorità competenti ed autorizzate. Il contenuto deve elencare i dati tecnici dell'automazione e le registrazioni delle attività di manutenzione e di riparazione.

Data Installazione Data Avviamento

Timbro con i dati dell'installatore

Nome Cliente, Indirizzo:

Descrizione Chiusura Aut.: n° di ante:

Ubicazione: n° Identificativo:

Modalità di Funzionamento: Tipo di Alimentazione:

Elenco dei rischi residui e dell'uso improprio prevedibile / eventuali note :

Firma Cliente / Responsabile:

Firma Installatore:

LISTA DEI CONTROLLI EFFETTUATI

- Stato / Funzionamento generale dell'automazione / stabilità meccanica
- Stato / Funzionamento di organi meccanici (ruote, cardini, cerniere)
- Funzionamento dello sblocco meccanico manuale

- Impianto elettrico: stato della centralina, interruttori, fine corsa, motore
- Funzionamento radiocomandi / ricevitore
- Funzionamento dispositivi di avviso (lampeggiante)

- Stato / Funzionamento dispositivi di sicurezza, bordi sensibili, fotocellule
- Controllo della limitazione delle forze (utilizzo dello strumento idoneo)

- Presenza dei cartelli indicatori / Targhetta CE

Tipologia dell'intervento: Manutenzione Riparazione

Note o Descrizioni Aggiuntive:

Data :

Firma Cliente / Responsabile:

Firma Installatore:

LISTA DEI CONTROLLI EFFETTUATI

- Stato / Funzionamento generale dell'automazione / stabilità meccanica
- Stato / Funzionamento di organi meccanici (ruote, cardini, cerniere)
- Funzionamento dello sblocco meccanico manuale

- Impianto elettrico: stato della centralina, interruttori, fine corsa, motore
- Funzionamento radiocomandi / ricevitore
- Funzionamento dispositivi di avviso (lampeggiante)

- Stato / Funzionamento dispositivi di sicurezza, bordi sensibili, fotocellule
- Controllo della limitazione delle forze (utilizzo dello strumento idoneo)

- Presenza dei cartelli indicatori / Targhetta CE

Tipologia dell'intervento: Manutenzione Riparazione

Note o Descrizioni Aggiuntive:

Data :

Firma Cliente / Responsabile:

Firma Installatore:

LISTA DEI CONTROLLI EFFETTUATI

- Stato / Funzionamento generale dell'automazione / stabilità meccanica
- Stato / Funzionamento di organi meccanici (ruote, cardini, cerniere)
- Funzionamento dello sblocco meccanico manuale

- Impianto elettrico: stato della centralina, interruttori, fine corsa, motore
- Funzionamento radiocomandi / ricevitore
- Funzionamento dispositivi di avviso (lampeggiante)

- Stato / Funzionamento dispositivi di sicurezza, bordi sensibili, fotocellule
- Controllo della limitazione delle forze (utilizzo dello strumento idoneo)

- Presenza dei cartelli indicatori / Targhetta CE

Tipologia dell'intervento: Manutenzione Riparazione

Note o Descrizioni Aggiuntive:

Data :

Firma Cliente / Responsabile:

Firma Installatore:

... continues REALISATION OF THE TECHNICAL FILE

■ Realisation and print of the Declaration of CE Conformity

The Declaration of CE Conformity lists all the applicable regulations (2006/42/EC) and the indication of the regulations or of the documents used to verify the conformity.

N.B. a copy of the CE Declaration must be given also to the customer.

<div style="border: 1px solid black; display: inline-block; padding: 5px 20px; font-weight: bold;">DICHIARAZIONE DI CONFORMITA' CE</div>	
	
■ IL SOTTOSCRITTO	
Nome:	
Indirizzo:	
■ IN QUALITA' DI RESPONSABILE PER LA MESSA IN FUNZIONE, DICHIARA CHE IL PRODOTTO:	
Tipo:	
Modello:	
■ RISULTA IN CONFORMITA' A QUANTO PREVISTO DALLE SEGUENTI DIRETTIVE COMUNITARIE: <small>(Comprese tutte le modifiche applicabili)</small>	
Direttiva Macchine 2006/42/CE	
Direttiva Compatibilità Elettromagnetica 2004/108/CE	
Direttiva Bassa Tensione 2006/95/CE	
Direttiva R&TTE 99/05/CE	
■ INOLTRE DICHIARA CHE SONO STATE APPLICATE LE NORME ARMONIZZATE E LE SPECIFICHE TECNICHE: <small>(Comprese tutte le modifiche applicabili)</small>	
<input type="checkbox"/> EN 13241-1: Cancelli e porte industriali, commerciali e residenziali - Norma di prodotto	
<input type="checkbox"/> EN 12453: Porte e cancelli industriali, commerciali e da garage - Sicurezza in uso di porte motorizzate Requisiti e metodi di prova	
<input type="checkbox"/> EN 16005: Porte pedonali motorizzate - Requisiti e metodi di prova	
<input type="checkbox"/> EN 60335-2-95: Porte da garage singole residenziali a movimento verticale	
<input type="checkbox"/> EN 12978: Dispositivi di sicurezza per porte e cancelli automatizzati	
<input type="checkbox"/> EN 12604: Requisiti meccanici di: porte, cancelli e barriere ad azionamento manuale	
<input type="checkbox"/> EN 12605: Metodi di prova di: porte, cancelli e barriere ad azionamento manuale	
<input type="checkbox"/>	
LUOGO:	DATA:
NOME DEL RESPONSABILE LEGALE:	
FIRMA:	
<small>Microtronics S.r.l. non si assume alcuna responsabilità su compilazioni non corrispondenti o errate</small>	

... continues REALISATION OF THE TECHNICAL FILE

THE CE MARKING

On automatic gate/door must be applied the plate with the references for the CE marking (see example next).

Note: it is possible that the gate/door has been automated later, consequently some data could be difficult to find; in any case it is always possible to insert the following data:

- CE marking
- Name and address of the builder
- Kind of automation
- Serial number (if present)
- Year of production
- Reference Regulations

 **microtronics**TM
Professional Instruments



COSTRUTTORE:

INDIRIZZO:

- Tipologia:
- Numero di serie:
- Dimensioni :
- Peso:
- Anno di produzione:
- Norme di Riferimento: UNI EN 13241-1, 2006/42/CE
2006/95/CE, 2004/108/CE, 305/2011
- Numero DoP

CONCLUSIONS (DO NOT GET LOST IN THE DEEP WATERS OF REGULATIONS)

To conclude, let's summarise the essential points for the certification of an automatic gate/door and then some advices and basic precautions that the installer should adopt from the beginning to be sure to minimize the electrical and mechanical risks but above all, the ones related to the impact and crush forces.

- Work execution in accordance with best practice with the corresponding certification of conformity
- Realisation of the Technical File with all the necessary documentation
- Compilation of the Risks Assessment (it can be made with the help of Microtronics' simplified forms)
- Carry out of the impact force measurements (thanks to the **BlueForce Smart** and its software)
- Compilation of the Maintenance Register (see facsimile on page 7)
- Compilation of the CE Certificate and of the CE plate (see facsimile on page 8)

ADVICES FOR THE INSTALLER

- Advise the customer in the choice of the kind of door/gate, preferring, if possible, the lightest models with a simple structure, without sharp borders, dangerous protrusions or slots with the risk of entrapment.
- Install an engine/control unit of latest generation, with electronic control of the force
- Follow the assembly instructions of the engine and of potential safety devices suggested by the manufacturer of the automation.
- Certify the automation with "common sense", then prepare the documentation required by the regulation and attach the one of the purchased product.

RISK ASSESSMENT

The Risk Assessment is compulsory for preventing the accidents in the areas where there is a powered operated gate/door, unfortunately in relation with hazards could correspond different risks, consequently it is necessary to implement all the activities to eliminate or reduce as much as possible the level of the risk in the interested area and in the proximity of the automatic gate/door.

The Risk Assessment is composed of different technical documents (drawings, references to regulations, test reports, safety measures, etc..), for this reason it is recommended to attend specific courses on power operated gate/door or to use specific software.

Microtronics has realised some **Simplified Guides** (for every kind of gate/door) in which the list of the controls and the technical descriptions are already set, all you need is to check the defined sentences and to complete with your data.



This is the content of a Simplified Guide:

- **LEGEND (necessary for the correct compilation)**
 - General instructions for the compilation
 - List of the kind of risks caused by the movement of the leaf/leaves
 - Table of the minimum protection levels of the main edge
 - Graphic of the parameters of the impact force measurements
 - List of the solutions to be adopted to eliminate/reduce the kind of risks

- **Risk Assessment – Page 1, with:**
 - Space for the data of the customer and of the installer
 - Drawing of the gate/door on squared paper, necessary to identify the installed components
 - List of the used components (brand, model, etc...)

- **Risk Assessment – Page 2, with:**
 - List of the mechanical and structural hazards
 - Schema of the powered operated gate/door with the kind of hazards enumerated
 - Table with the list of the hazards and the adopted solutions.

- **Risk Assessment – Page 3, with:**
 - Description of the measurement limits of the impact forces
 - Description of the measurement positions of the impact forces
 - Table with the conclusive verifications related to safety
 - Space for the notes about the non-applicable verifications

Following it is represented the **Simplified Form** for the Risk Assessment of a **Sliding Gate**.

N.B. the form of the sliding gate can not be applied to the other kinds of gates/doors.



ANALISI DEI RISCHI - CANCELLO SCORREVOLE

IN CONFORMITA' ALLA DIRETTIVA MACCHINE: 2006/42/CE - NORME APPLICABILI: EN 13241 - EN 12453 - EN 12878

Nome Cliente:
 Indirizzo:
 Descrizione Chiusura Aut.:
 Ubicazione: n° Identificativo:

Timbro con i dati dell'installatore

LOCALIZZAZIONE DEI COMPONENTI ELETTRICI / ELETTRONICI

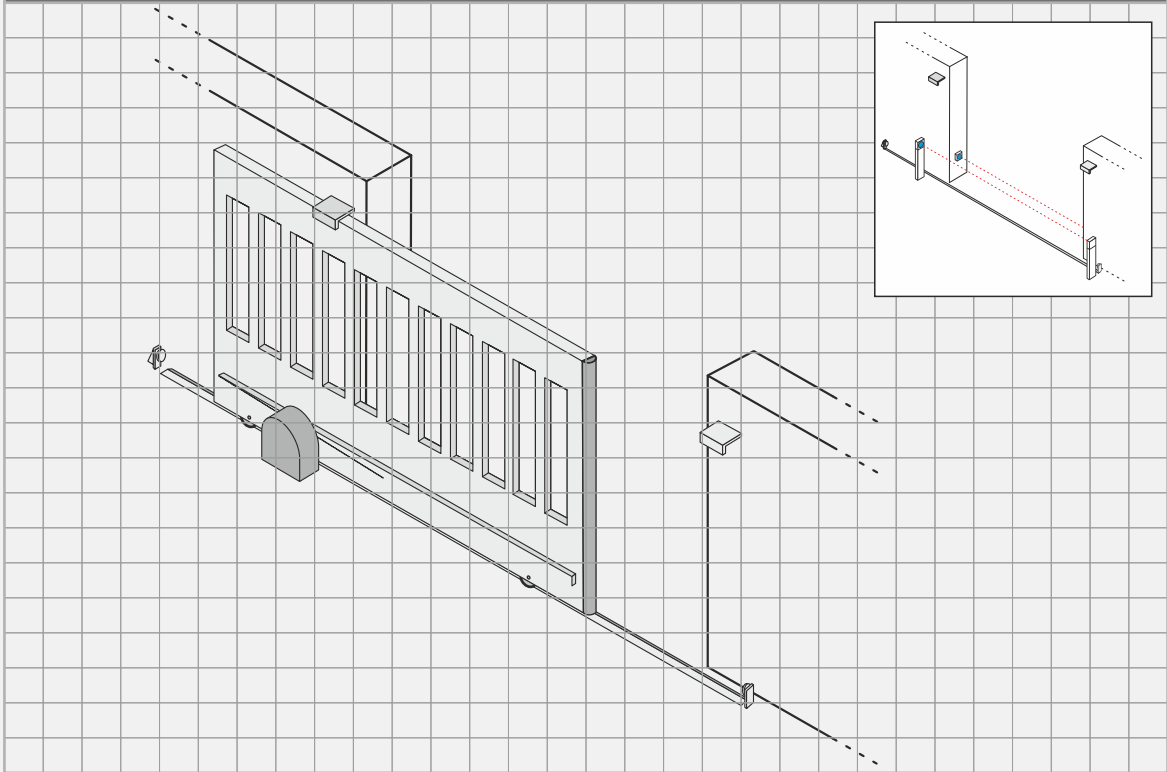

ELENCO COMPONENTI ELETTRICI / ELETTRONICI UTILIZZATI

NOME COMPONENTE	MARCA - MODELLO - TIPO
1 Motore
2 Centralina comando
3 Centralina ricevitore
4 Antenna ricevitore
5 Lampeggiante 1
6 Lampeggiante 2
7 Fotocellule interne
8 Fotocellule esterne
9 Comando a chiave / pulsante
10 Comando a tastiera / scheda
11 Bordo sensibile anteriore
12 Bordo sensibile posteriore
13 Pedana sensibile
14
15

ELENCO RISCHI MECCANICI STRUTTURALI

- | | | |
|--------------------------|--------------------------|---|
| OK | NON APPLICABILE | |
| ↑ | ↑ | |
| <input type="checkbox"/> | <input type="checkbox"/> | Stato e funzionamento generale dell'automazione |
| <input type="checkbox"/> | <input type="checkbox"/> | Solidità e stabilità della struttura e degli organi meccanici di sostegno |
| <input type="checkbox"/> | <input type="checkbox"/> | Stato e usura di ruote/cuscinetti/cardini e/o sistemi di scorrimento |
| <input type="checkbox"/> | <input type="checkbox"/> | Stato e fissaggio del motore o degli organi adibiti al movimento |
| <input type="checkbox"/> | <input type="checkbox"/> | Soglie o guide/rotaie (se più alte di 5 mm devono essere livellate o evidenziate) |
| <input type="checkbox"/> | <input type="checkbox"/> | Stato e solidità dei fermi meccanici di fine corsa |

LOCALIZZAZIONE E IDENTIFICAZIONE DELLE TIPOLOGIE DI RISCHIO

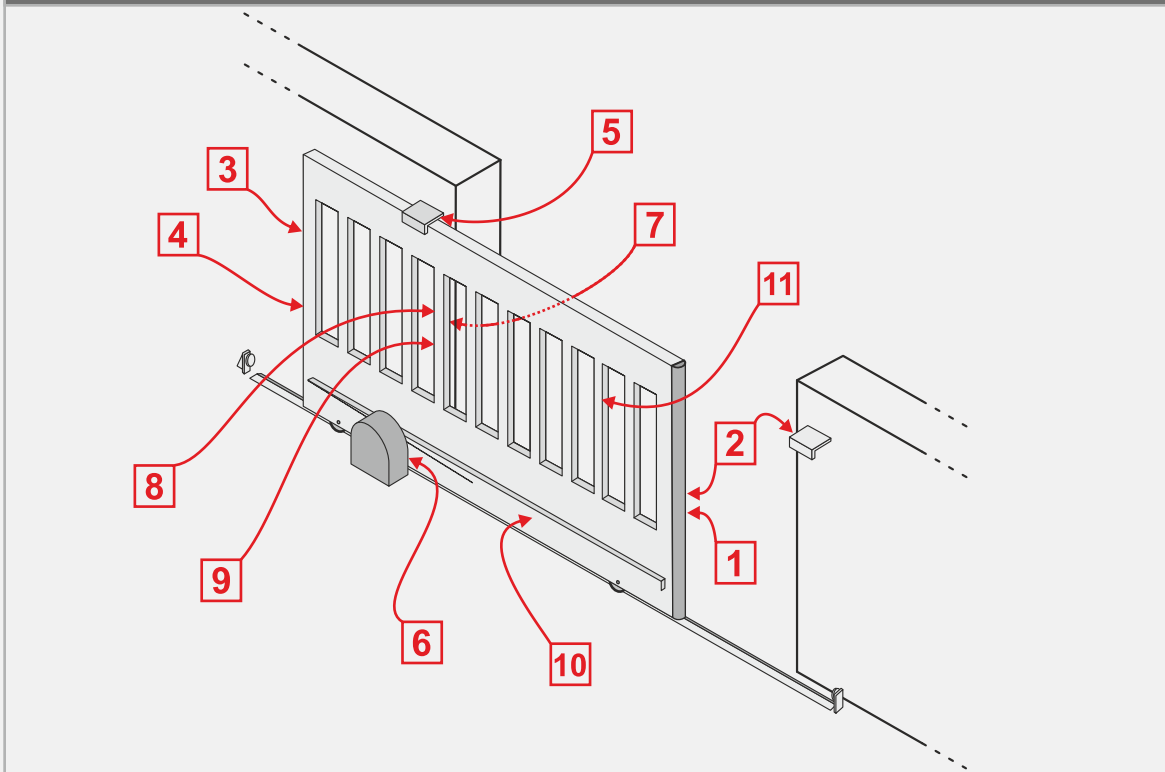

ELENCO DEI RISCHI - SOLUZIONI ADOTTATE

OK	NON APPLICABILE	TIPO RISCHIO	DESCRIZIONE DELLA PROTEZIONE / CONTROLLO APPLICATO
<input type="checkbox"/>	<input type="checkbox"/>	1 Impatto/Spinta Anteriore
<input type="checkbox"/>	<input type="checkbox"/>	2 Schiacciamento Anteriore
<input type="checkbox"/>	<input type="checkbox"/>	3 Impatto/Spinta Posteriore
<input type="checkbox"/>	<input type="checkbox"/>	4 Schiacciamento Posteriore
<input type="checkbox"/>	<input type="checkbox"/>	5 Convogliamento
<input type="checkbox"/>	<input type="checkbox"/>	6 Convogliamento
<input type="checkbox"/>	<input type="checkbox"/>	7 Cesoiamento
<input type="checkbox"/>	<input type="checkbox"/>	8 Cesoiamento
<input type="checkbox"/>	<input type="checkbox"/>	9 Taglio
<input type="checkbox"/>	<input type="checkbox"/>	10 Uncinamento
<input type="checkbox"/>	<input type="checkbox"/>	11 Uncinamento
<input type="checkbox"/>	<input type="checkbox"/>	<input type="checkbox"/>

IMPATTO E SCHIACCIAMENTO SUL BORDO PRINCIPALE DI CHIUSURA - MISURE D'IMPATTO

LIMITI DELLE FORZE D'IMPATTO

Aperture tra bordi di chiusura tra 50mm e 500 mm - **FD max. 400N**

Aperture tra bordi di chiusura superiori a 500 mm - **FD max. 1400N**

POSIZIONI E DISTANZE PER MISURA DELLE FORZE D'IMPATTO

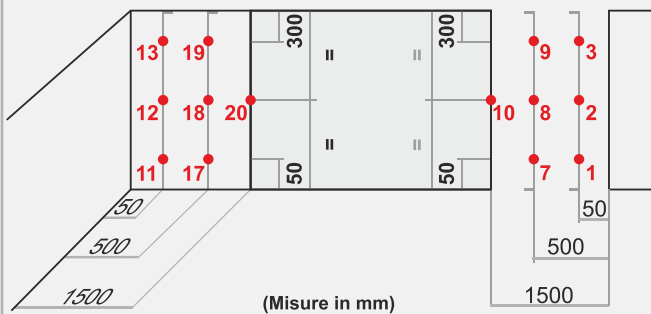

MISURA D'IMPATTO

(con lo strumento BlueForce Smart)

Ogni misura deve essere ripetuta **tre volte** per ogni punto di misura ed alle relative distanze (vedi immagine a lato), il valore utile è la media delle tre prove. Se si utilizza il software BlueForce è consigliabile allegare il **Report di Stampa** con le misure effettuate.



AVVERTENZE

- **NON** è necessario effettuare la misura sulla parte posteriore del cancello se la distanza di sicurezza tra il bordo e l'eventuale muro/ostacolo è: **≥ di 500 mm.**
- **NON** è necessario effettuare la misura di forza sul bordo principale se l'azione viene effettuata da un "uomo presente" con un comando "senza ritenuta" e l'automazione è sempre "a vista".
- **NON** è necessario effettuare la misura di forza sul bordo principale, se sono stati installati dei dispositivi di sicurezza tipo "E" (descritti nella EN 12978, chiamati anche sensori di presenza o barriere fotoelettriche).

VERIFICHE CONCLUSIVE RELATIVE ALLA SICUREZZA E ALL'AFFIDABILITA'

- | | |
|-------------------------------|--|
| OK

NON
APPLICABILE | <input type="checkbox"/> <input type="checkbox"/> Verificare il regolare funzionamento delle fotocellule interne ed esterne con i parallelepipedi di prova
<input type="checkbox"/> <input type="checkbox"/> Verificare che sia presente un sistema di sblocco manuale/meccanico (che permetta la chiusura/apertura manuale dell'anta)
<input type="checkbox"/> <input type="checkbox"/> Verificare che l'impianto elettrico sia protetto da un sezionatore/interruttore elettrico e che non sia accessibile involontariamente
<input type="checkbox"/> <input type="checkbox"/> Verificare che il selettore o il comando manuale non sia posizionato in una zona pericolosa per l'utilizzatore
<input type="checkbox"/> <input type="checkbox"/> Verificare che il gruppo di azionamento/motore riprenda il suo regolare funzionamento dopo una interruzione (blocco alimentazione)
<input type="checkbox"/> <input type="checkbox"/> Verificare che il gruppo di azionamento/motore sia conforme alle Norme EN12453 ed EN12978
<input type="checkbox"/> <input type="checkbox"/> Se il gruppo di azionamento/motore è di tipo "Idraulico" verificare che sia conforme alla Norma EN982
<input type="checkbox"/> <input type="checkbox"/> Se il gruppo di azionamento/motore è di tipo "Pneumatico" verificare che sia conforme alla Norma EN983
<input type="checkbox"/> <input type="checkbox"/> Verificare che nel Fascicolo Tecnico siano presenti le conformità CE dei componenti dell'automazione
<input type="checkbox"/> <input type="checkbox"/> Verificare che nel Fascicolo Tecnico (per i componenti interessati) sia presente la conformità EMC Compatibilità Elettromagnetica
<input type="checkbox"/> <input type="checkbox"/> Verificare che nel Fascicolo Tecnico (per i componenti interessati) sia presente la conformità R&TTE Trasmissioni/Frequenze Radio
<input type="checkbox"/> <input type="checkbox"/>
<input type="checkbox"/> <input type="checkbox"/>

<input type="checkbox"/> <input type="checkbox"/> Verificare che siano presenti dei segnali/cartelli da ritenersi necessari per evidenziare dei rischi residui non protetti e per segnalare eventuali usi non conformi prevedibili, ad es: |
|-------------------------------|--|



NOTE RELATIVE ALLE VERIFICHE NON APPLICABILI

.....

.....

.....

.....

.....

.....

.....

.....

.....

.....

Data: Firma Cliente: Firma Installatore: Pag. 3 di 3

Sliding Gate

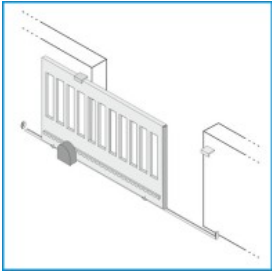

Swing Gates

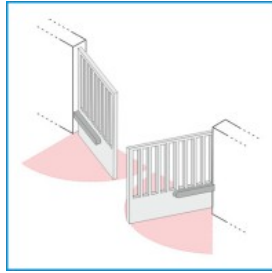

Barrier

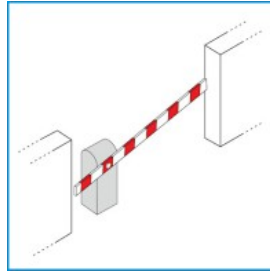

Tilting Door

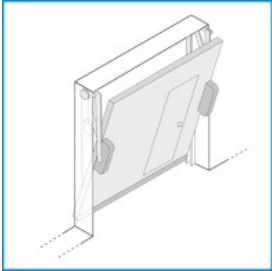

Folding Door

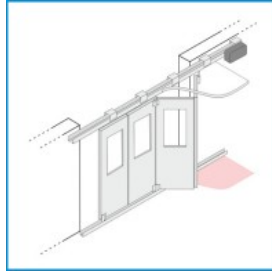

Sectional Rigid Door

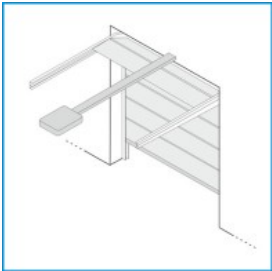

Vertical Rolling Shutter

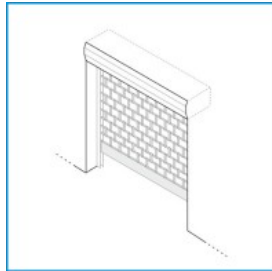

Flexible Sectional Door

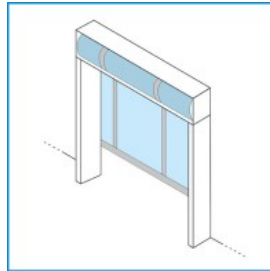

Pedestrian Swing Door

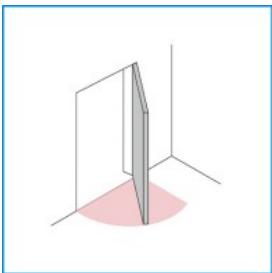

Pedestrian Sliding Door

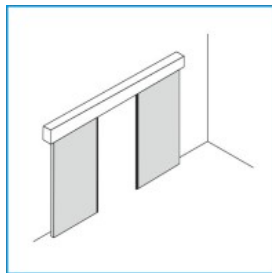

Pedestrian Rotating Door

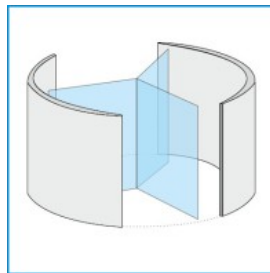

Power-operated windows

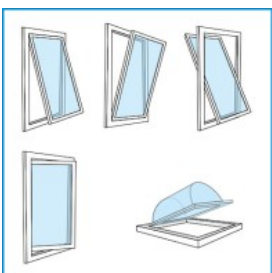

Safe Gates

Edition 2018

All rights reserved
Copyright 2006 – 2018
MICROTRONICS SRL