



BEST PRACTICES IN **ELECTRICAL INTEGRATION** OF THE FLEXIFORCE™ SENSOR

Thin, customizable FlexiForce sensors measure normal compressive forces in your device. While every application is unique, there are some universal considerations and general best practices to consider to achieve optimal performance of the FlexiForce™ sensor in your application.

This document is intended to illustrate electrical design concepts to consider while integrating FlexiForce sensors into a product or device. Refer to the "FlexiForce Integration Guide" for more detailed information, and contact Tekscan for recommendations on electrical design specific to your application.

NOTE: The specific circuits in this document are not the only circuit designs that can be used with FlexiForce sensors. We encourage you to engage with our Applications Engineering team early in your process.

TABLE OF CONTENTS

- 1** Circuit Selection (Pages 3-7)
 - Inverting Op-Amp Circuit (Page 4)
 - Non-Inverting Op-Amp Circuit (Page 5)
 - Voltage Divider Circuit (Page 6)
 - Advantages & Disadvantages of Recommended Circuits (Page 7)

- 2** Develop Sensitivity Adjustment and Calibration Procedure (Page 8)

- 3** Calibration Walk-Through Example (Page 9)

- 4** Additional Resources; What's Next (Page 10)

1 CIRCUIT SELECTION

TEKSCAN RECOMMENDS CHOOSING FROM ONE OF THREE CIRCUITS TO OPERATE FLEXIFORCE SENSORS

**INVERTING
OP-AMP CIRCUIT**
(DUAL SOURCE)

**NON-INVERTING
OP-AMP CIRCUIT**
(SINGLE SOURCE)

VOLTAGE DIVIDER

CONSIDERATIONS

The Inverting circuit, the Non-Inverting circuit, and the Voltage Divider have several methods that can be employed to adjust the sensitivity to increase or decrease the maximum force that can be measured over the full-scale dynamic range. This sensitivity adjustment of the circuit should be used for two purposes:

- Adjustment of the maximum force rating for the circuit to fit the applied force of the application
- Account for variation between different sensors – FlexiForce sensors have an inherent part-to-part variation.*
- A duty cycle is recommended for extending sensor life, regardless of chosen circuit. Apply a duty cycle of 50% or less. Lower duty cycles can potentially increase battery and sensor life.
- Choose electrical components best suited for the application (i.e. Op-Amp). Considerations include power supply, speed, precision, and power consumption. **Data in this document was collected using the MCP6004.**

If your application cannot allow for a duty cycle, refer to the recommended DC reference voltage values in the following sections.

**CONSULT THE "MECHANICAL BEST PRACTICES GUIDE" DOCUMENTATION REGARDING EFFECTS OF:
INTERFACE MATERIAL | LOAD CONCENTRATION | ENVIRONMENT**

*+/-40% lower resistance - higher circuit output | +/-40% higher resistance - lower circuit output

INVERTING OP-AMP CIRCUIT (DUAL SOURCE)

Adjustable feedback resistance: Using a potentiometer (analog or digital) as feedback resistor to change force sensitivity.

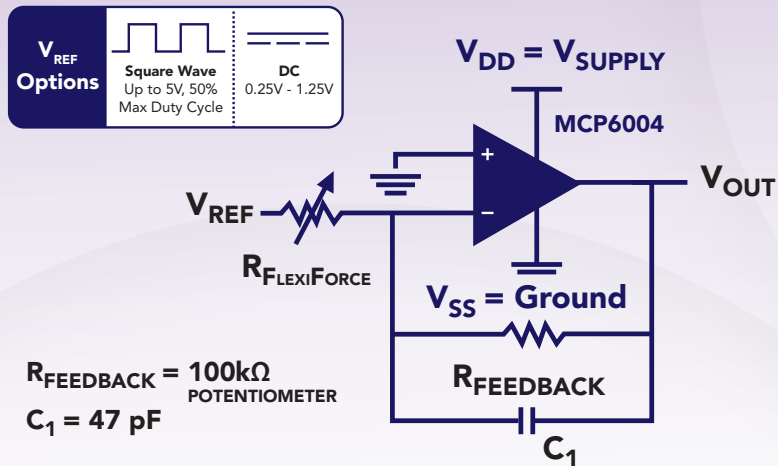

100K POTENTIOMETER AND 47 pF ARE GENERAL RECOMMENDATIONS; YOUR SPECIFIC SENSOR MAY BE BEST SUITED WITH A DIFFERENT POTENTIOMETER AND CAPACITOR. TESTING SHOULD BE PERFORMED TO DETERMINE THIS.

POLARITY OF V_{REF} MUST BE OPPOSITE THE POLARITY OF V_{SUPPLY}.

NOTE: MAX CURRENT RATING FOR FLEXIFORCE SENSORS IS 2.5 mA.

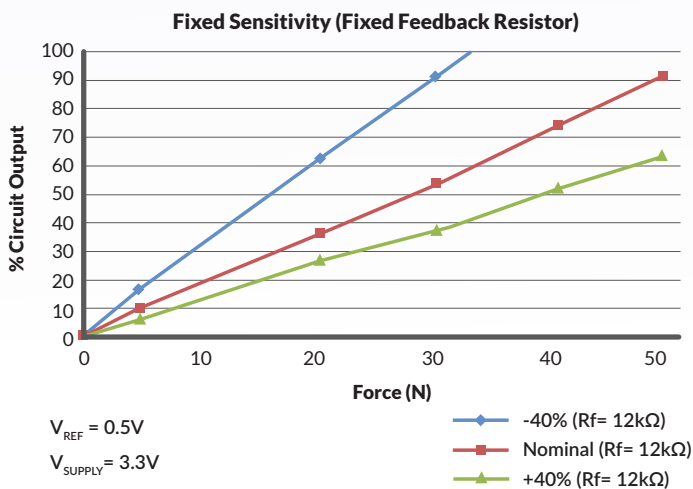

MORE SENSITIVE SENSORS SATURATE BEFORE MAX FORCE.

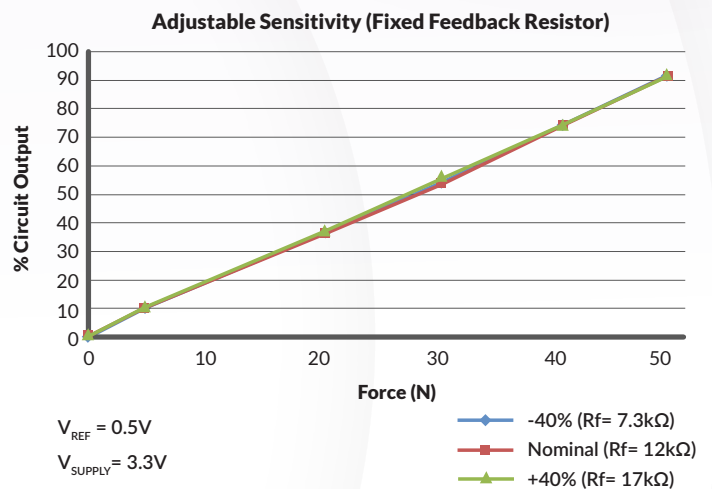

ALL SENSORS OPERATE WITHIN DYNAMIC FORCE RANGE.

Adjustable drive voltage of a Inverting Op-Amp circuit: This method of adjustable sensitivity can be implemented by using voltage divider or Digital to Analog Converter (DAC) to adjust the reference voltage so that the maximum force can be measured throughout the variation of Tekscan sensors. Consult the "FlexiForce Integration Guide" for models & graphs.

NON-INVERTING OP-AMP CIRCUIT (SINGLE SOURCE)

A Non-Inverting configuration has a fixed offset, and can be used with a single power supply.

Adjustable feedback resistance: Using a potentiometer (analog or digital) as feedback resistor to change force sensitivity.

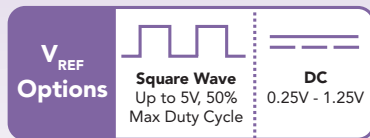

$$R_{\text{FEEDBACK}} = 100\text{k}\Omega \text{ POTENTIOMETER}$$

$$C_1 = 47 \text{ pF}$$

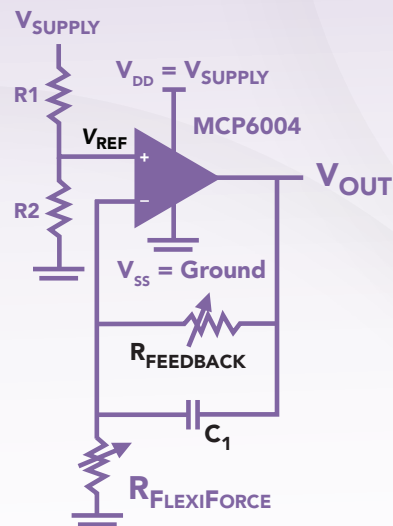

100K POTENTIOMETER AND 47 pF ARE GENERAL RECOMMENDATIONS; YOUR SPECIFIC SENSOR MAY BE BEST SUITED WITH A DIFFERENT POTENTIOMETER AND CAPACITOR. TESTING SHOULD BE PERFORMED TO DETERMINE THIS.

NOTE: MAX CURRENT RATING FOR FLEXIFORCE SENSORS IS 2.5 mA.

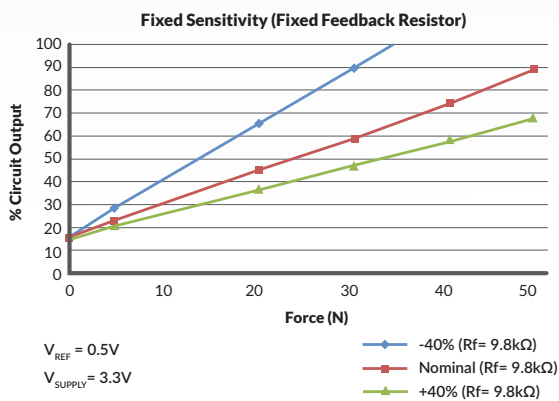

MORE SENSITIVE SENSORS SATURATE BEFORE MAX FORCE.

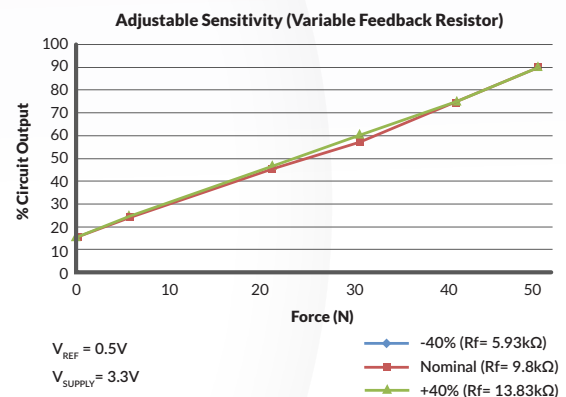

ALL SENSORS OPERATE WITHIN DYNAMIC FORCE RANGE.

Adjustable drive voltage of a Non-Inverting Op-Amp circuit: This method of adjustable sensitivity can be implemented by using voltage divider or Digital to Analog Converter (DAC) to adjust the reference voltage so that the maximum force can be measured throughout the variation of Tekscan sensors. Consult the "FlexiForce Integration Guide" for models & graphs.

VOLTAGE DIVIDER

Adjustable in-line resistance: Use a potentiometer to adjust R_1 to increase or decrease force sensitivity.

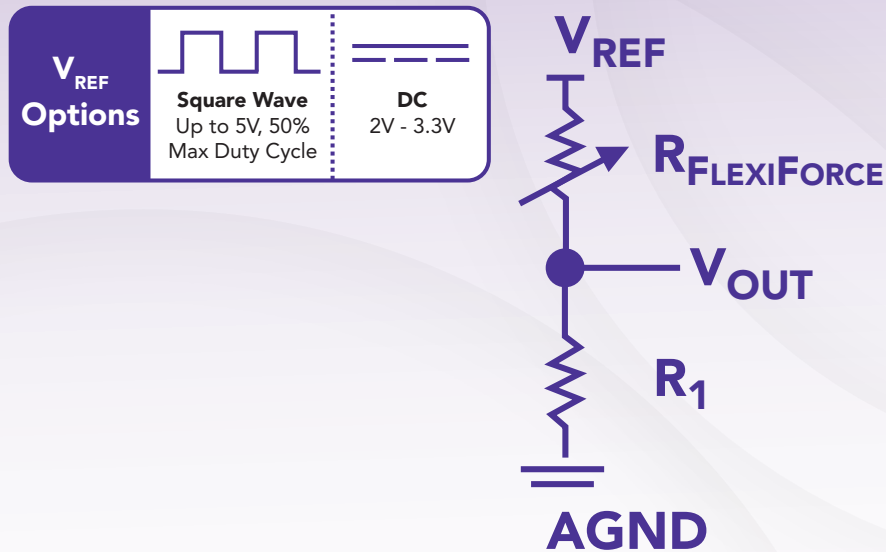

Voltage Divider with Adjustability

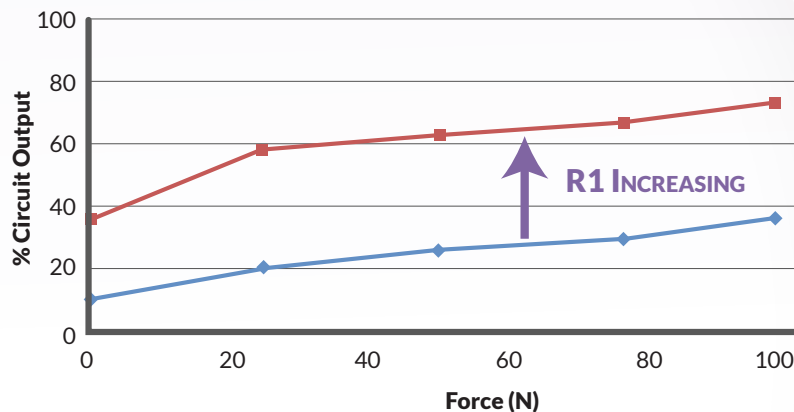

NOTE: MAX CURRENT RATING FOR FLEXIFORCE SENSORS IS 2.5 mA.

If your application cannot allow for a duty cycle, use a minimum DC reference voltage of 3.3V or less.

Adjustable drive voltage of a Voltage Divider circuit: This method of adjustable sensitivity can be implemented by using a Digital to Analog Converter (DAC) to adjust the reference voltage so that the maximum force can be measured throughout the variation of Tekscan sensors. **Consult the "FlexiForce Integration Guide" for models & graphs.**

ADVANTAGES & DISADVANTAGES OF RECOMMENDED CIRCUITS

INVERTING OP-AMP CIRCUIT (DUAL SOURCE)

ADVANTAGES

Excellent linearity in voltage output with respect to force applied throughout the dynamic range of the circuit.

Dynamic range ($\sim 0-V_{\text{supply}}$)

DISADVANTAGES

Slightly more complex circuit design and more expensive than the Voltage Divider.

Requires dual power supplies.

NON-INVERTING OP-AMP CIRCUIT (SINGLE SOURCE)

ADVANTAGES

Excellent linearity in voltage output with respect to force applied throughout the dynamic range of the circuit.

Can be powered with a single power supply.

DISADVANTAGES

Slightly more complex circuit design and more expensive than the Voltage Divider.

Dynamic range ($V_{\text{ref}}-V_{\text{supply}}$)

VOLTAGE DIVIDER

ADVANTAGES

Inexpensive & simple.

Single supply.

DISADVANTAGES

Less linear output compared to the Inverting or Non-Inverting circuit.

No isolation to the rest of the circuit.

ADDITIONAL RECOMMENDATIONS

- All adjustable resistors shown on previous pages can use either digital or analog potentiometers.
- Lower reference voltages (0.25-0.75V) reduce power consumption, and provide more force range and resolution adjustability.
- Mechanical design heavily influences sensor behavior, and should be complete before finalizing circuit designs. Consult the "Mechanical Best Practices Guide" documentation regarding effects of:
 - Interface material
 - Load concentration
 - Environment

THESE ARE COMMON CIRCUIT EXAMPLES; OTHER DESIGN OPTIONS MAY BE AVAILABLE.
CONSULT WITH TEKSCAN APPLICATIONS ENGINEERS BEFORE FINALIZING EMBEDDED CIRCUIT DESIGNS.

2 DEVELOP SENSITIVITY ADJUSTMENT AND CALIBRATION PROCEDURE

Sensitivity adjustment: Use the circuit's sensitivity adjustment method to set the output of the circuit to 80%-90% of full-scale at maximum applied force.

Calibration: Apply known force to the sensor to correlate voltage output to engineering units (lbs, N, psi, etc). Because of the inherent part-to-part variation in FlexiForce sensors, independent/individual sensor calibration is crucial for achieving accurate results.

Before calibration:

1. Fully assemble device to be in the same state or as similar as possible, to when it will be used in the field
2. If possible, condition the sensor. We generally recommend loading the sensor to 120% of maximum expected force and cycling 3-5 times for 10 seconds at a time
3. Adjusting the sensitivity of the circuit to max output at 120% max load, or 80-90% output at 100% load allows some overhead for spikes in force/pressure. This process ensures that the circuit does not saturate before your maximum expected force. Using one of the circuits and a circuit design process previously described in Sections 1 & 2 will help ensure the circuit sensitivity can be properly adjusted throughout the range of possible sensor resistances.

During calibration:

USE COMPLETED ASSEMBLY,
OR AS CLOSE TO COMPLETED
AS POSSIBLE

USE FORCE LEVELS WITHIN
THE EXPECTED APPLICATION
FORCE RANGE

USE THE SAME LOAD
DURATION AS EXPECTED
DURING THE APPLICATION

3 CALIBRATION WALK-THROUGH EXAMPLE

CONDITION THE SENSOR (RECOMMENDED)

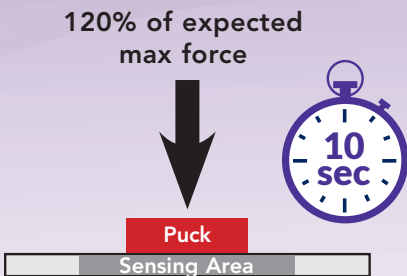

Conditioning is only required prior to factory calibration.

Apply & remove force at 120% of the expected max force 3-5 times, 10 seconds each time.

ADJUST CIRCUIT SENSITIVITY TO 90% OF CIRCUIT'S MAX OUTPUT

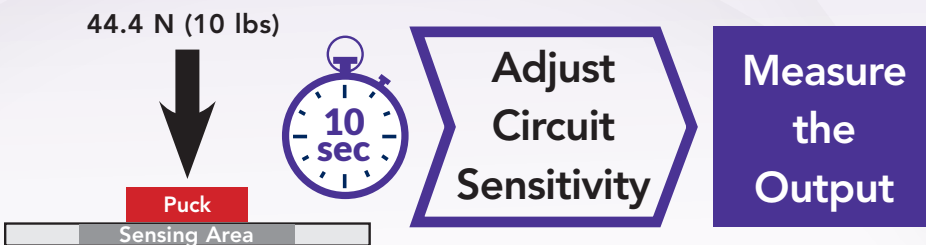

Apply max expected force. Adjust sensitivity so that output is 90% of the circuit's maximum output. Remove force.

Refer to Section 2 of this document, or the "FlexiForce Integration Guide" for sensitivity adjustment methods.

NOTE: IN THIS EXAMPLE, THE CIRCUIT SATURATES AT 3.3V. MAX EXPECTED LOAD IS 44.4 N (10 LBS).

PLOT FORCE VS RECORDED OUTPUT

We generally recommend a two-to-three point calibration. First record the circuit output with the sensor unloaded, then:

1. Apply a low calibration point of 10% max load
2. (Optional) Apply a mid calibration point at 50% max load, if desired
3. Apply a high calibration point at 100% of max load

Record circuit output at each load.

In this example, we are recording circuit output with the sensor unloaded, then applying 4.4 N, 22.2 N, and 44.4 N (1 lb, 5 lbs, and 10 lbs, respectively) sequentially at the expected loading time interval.

Force (N (lbs))	Circuit Output (V)
0 (0)	0.51
4.4 (1)	0.75
22.2 (5)	1.70
44.4 (10)	2.96

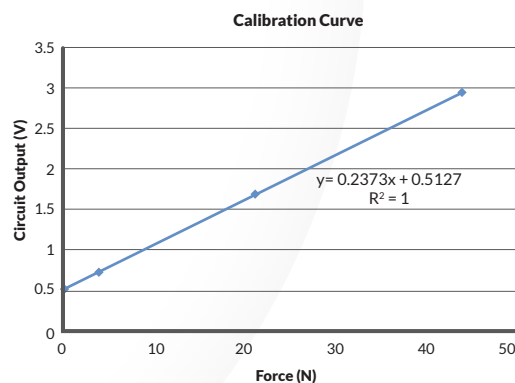

NOTE: CALIBRATION CAN ALSO BE CARRIED OUT AS A FUNCTION OF ADC COUNTS IF ADC IS BEING USED.

4

ADDITIONAL RESOURCES

BEST PRACTICES IN MECHANICAL INTEGRATION

The complete **“Best Practices in Mechanical Integration”** guide provides key recommendations to consider during the prototyping phase of your OEM project. This includes:

- Applying load concentrators to ensure even loading
- Recommendations to minimize shear force and preserve sensor sensitivity
- Methods for mounting the sensor, and more!

FLEXIFORCE INTEGRATION GUIDE

For in-depth OEM integration recommendations, download the complete **“FlexiForce Integration Guide.”** This guide is intended to help you optimize design, reduce costs, and streamline the overall sensor design & embedding process from prototype to production.

The **“FlexiForce Integration Guide”** includes additional electrical considerations to help with your OEM project, including:

- Characterizing sensor performance
- Soldering
- Effects of temperature on circuit and calibration
- Sensor/circuit duty cycle
- Design walk-thru examples, and more!

WHAT'S NEXT?

Are you considering embedding a FlexiForce sensor into your product? Contact our Application Engineering team today to help bring your OEM project to life.

CONTACT US: 1.800.248.3669 / +1.617.464.4283

WWW.TEKSCAN.COM/FLEXIFORCE

