

# GX 1030











**Function/Arbitrary Waveform Generator**

Thank you for purchasing a **GX 1030 Function/Arbitrary Waveform Generator**.

For best results from your device:

- **read** this user's manual carefully,
- **comply with** the precautions for use.

	WARNING, risk of DANGER ! The operator should refer to this user's manual whenever this danger symbol appears.
	The instrument should be operating continuously for more than 30 minutes within specified operating temperature range (18°C ~ 28°C).
	WARNING! Risk of electric shock. The voltage on the parts marked with this symbol may be dangerous.
	Earth.
	Chassis ground
	The CE marking indicates compliance with the European Low Voltage Directive (2014/35/EU), Electromagnetic Compatibility Directive (2014/30/EU), and Restriction of Hazardous Substances Directive (RoHS, 2011/65/EU and 2015/863/EU).
	The UKCA marking certifies that the product is compliant with the requirements that apply in the United Kingdom, in particular as regards Low-Voltage Safety, Electromagnetic Compatibility, and the Restriction of Hazardous Substances.
	The rubbish bin with a line through it indicates that, in the European Union, the product must undergo selective disposal in compliance with Directive WEEE 2012/19/EU. This equipment must not be treated as household waste.

**Definitions of the measurement categories**

- Measurement category IV corresponds to measurements taken at the source of low-voltage installations. Example: power feeders, meters and protection devices.
- Measurement category III corresponds to measurements on building installations. Example: distribution panel, circuit-breakers, machines or fixed industrial devices.
- Measurement category II corresponds to measurements taken on circuits directly connected to low-voltage installations. Example: power supply to domestic electrical appliances and portable tools.

**Definitions of overvoltage categories**

- Overvoltage category IV concerns equipment installed where the power supply enters a building, or nearby, between the point of entry and the main distribution frame. This equipment can include electricity meters and primary overvoltage protection devices.  
Overvoltage category III concerns equipment that is part of the electrical installation of a building. This equipment includes sockets, fuse panels, and some network installation control devices.
- Overvoltage category II concerns equipment designed to be supplied from the electrical installation of the building. It includes both equipment connected by plugs and equipment connected permanently.

# CONTENTS

<b>1. DELIVERY CONDITION</b> .....	<b>5</b>
<b>2. PRESENTATION</b> .....	<b>6</b>
2.1. Key features .....	6
2.2. Output connections.....	6
2.3. Impedance adaptation .....	6
<b>3. DESCRIPTION OF THE INSTRUMENT</b> .....	<b>7</b>
3.1. Getting started .....	7
3.2. Handle adjustment.....	8
3.3. The Front/Rear Panel and User Interface .....	9
<b>4. FUNCTIONAL DESCRIPTION</b> .....	<b>11</b>
4.1. To select the waveform .....	11
4.2. To Set Modulation/Sweep/Burst .....	14
4.3. To Turn On/Off Output .....	15
4.4. To Use Numeric Input .....	15
4.5. To Use Common Function Keys .....	16
<b>5. FUNCTIONAL DESCRIPTION - HOW TO MEASURE THE DIFFERENT WAVEFORMS ?</b> .....	<b>17</b>
5.1. To Set Sine Waveform .....	17
5.2. To Set Square Waveform.....	20
5.3. To Set Ramp Waveform.....	21
5.4. To Set Pulse Waveform .....	22
5.5. To Set Noise Waveform .....	24
5.6. To Set DC Waveform .....	26
5.7. To Set Arbitrary Waveform.....	26
5.8. To Set Harmonic Function .....	33
5.9. To Set Modulation Function .....	34
5.10. To Set Sweep Function.....	42
5.11. To Set Burst Function.....	45
<b>6. TO STORE AND RECALL</b> .....	<b>48</b>
6.1. Storage System .....	49
6.2. File Type .....	49
6.3. File Operation .....	50
<b>7. TO SET UTILITY FUNCTION</b> .....	<b>52</b>
7.1. System settings .....	53
7.2. Test/Cal .....	58
7.3. Frequency Counter.....	61
7.4. Output.....	62
7.5. CH Copy/Coupling.....	64
7.6. Remote Interface .....	66
7.7. Sync Output.....	71
7.8. Clock Source .....	72
7.9. Phase Mode .....	72
7.10. Overvoltage Protection .....	73
<b>8. TROUBLE SHOOTING</b> .....	<b>74</b>
<b>9. TECHNICAL SPECIFICATIONS</b> .....	<b>74</b>
9.1. General .....	74
9.2. Waveforms specifications .....	75
9.3. Output Specification .....	75
9.4. DC Offset.....	76
9.5. Waveform Output.....	76
9.6. Modulation .....	76
9.7. Sweep CH1 / CH2 .....	77
9.8. Burst CH1/CH2.....	77
9.9. Reference clock Input/Output .....	77
9.10. Auxiliary In/Out Characteristics.....	77
<b>10. REFERENCE CONDITIONS</b> .....	<b>78</b>
10.1. Environmental conditions .....	78
10.2. Mechanical characteristics .....	78
10.3. Conformity to international standards / Electrical safety.....	79
10.4. Electromagnetic compatibility .....	79
<b>11. MAINTENANCE</b> .....	<b>79</b>
11.1. Cleaning.....	79
11.2. Updating of the internal software .....	79
<b>12. WARRANTY</b> .....	<b>80</b>

# PRECAUTIONS FOR USE

This instrument is designed to be powered by a mains voltage of category II. The main energy sources are 120 V eff or 240 V eff. Use only the power cord supplied with the unit.

Carefully read the following safety precautions to avoid any personal injuries or damages to the instrument and any product connected to it. To avoid potential hazards, please use the instrument as specified.

Failure to observe the safety instructions may result in electric shock, fire, explosion, or destruction of the instrument and of the installations.

Observe all terminal ratings. To avoid fire or electric shock, please observe all ratings and sign instructions on the instrument. Before connecting the instrument, please read the manual carefully to gain more information about the ratings.

- The operator and/or the responsible authority must carefully read and clearly understand the various precautions to be taken in use. Sound knowledge and a keen awareness of electrical hazards are essential when using this instrument.
- If you use this instrument other than as specified, the protection it provides may be compromised, thereby endangering you.
- Do not use the instrument if it seems to be damaged, incomplete, or poorly closed.
- Before each use, check the condition of the insulation on the leads, housing, and accessories. Any item of which the insulation is deteriorated (even partially) must be set aside for repair or scrapping.
- Ground the Instrument. The instrument is grounded through the protective ground conductor of the power line. To avoid electric shock, the ground conductor must be connected to the earth ground. Make sure the instrument is grounded correctly before connecting its input or output terminals.
- Do not alter or remove the grounding. Without grounding, all conductive elements (including control buttons) can cause electrocution. Failure to follow these instructions may result in injury or death.
- Before using your device, check that it is perfectly dry. If it is wet, it must be thoroughly dried before being connected or being operated in any way.
- Use personal protection equipment systematically.
- When handling the leads, test probes, and crocodile clips, keep your fingers behind the physical guard.
- Connect the signal wire correctly. The potential of the signal wire ground is equal to the earth, therefore do not connect the signal wire to a high voltage. Do not touch the exposed contacts or components.
- Use properly rated power line connections. Use only the specified power line which has been approved by your local regulatory agency.
- All troubleshooting and metrological checks must be performed by competent and accredited personnel.
- When using the device, keep your fingers behind the physical guard.
- Avoid circuit or wire exposure. Do not touch exposed contacts or components when the power is on.
- The safety of any system in which this device is incorporated is the responsibility of the system integrator.
- Unless otherwise specified, grounding on the front or rear panel of the unit is only indicative and is not without risk.
- Do not use the device in an explosive or flammable atmosphere.
- Comply with the environmental conditions of use:
  - Do not operate in wet/damp conditions.
  - Do not operate:
    - in an explosive atmosphere.
    - In a harmful or corrosive environment, in the presence of smoke, flammable gases or vapors and fine particles
    - If the temperature is different from the operating temperature specified in this manual.
    - At a high altitude that would alter atmospheric pressure or if the ambient gas is not air.
    - In environments where air circulation is difficult, even if temperatures are within specifications.
    - In full sun.
- Keep the surface of the instrument clean and dry.

This instrument is designed for use in a place with a degree of pollution 2. The operating temperature is between 0°C and 40°C, Operating humidity must be 90% relative humidity at < 35°C and 60% relative humidity at 35°C – 40°C non-condensing. The measurement may be distorted if carried out in a non-compliant environment. The measurement may be distorted if carried out in an environment subject to rapid variations in temperature, humidity or brightness, mechanical vibration or shock, electrical noise or disturbance, high magnetic or electrical field.

This instrument contains one or more fans. For the continued safe use of the appliance, it is essential that the air inlets and exhaust ports are not obstructed by dust or debris that could reduce the airflow. Leave a gap of at least 25mm around each side of the instrument that contains air inlets and air exhaust ports. If the instrument is installed in a test bay, position the power devices above the instrument to reduce circuit heating. Do not use the instrument if you cannot verify the proper operation of the fan(s) (note that some fans may have an intermittent operating cycle). Do not insert any objects into or out of the fan.

- For safe use of the device
  - Do not place heavy objects on the instrument.
  - Do not obstruct the instrument's cooling airflow.
  - Do not place a hot soldering iron on the instrument.
  - Do not pull the instrument by the power cord or its test cables.
  - Never move the instrument when cables are connected to an application

### Power input voltage

The instrument has a universal power supply that accepts a mains voltage and a frequency between:

- 100 - 240 V ( $\pm 10\%$ ), 50 - 60 Hz ( $\pm 5\%$ )
- 100 - 127 V, 45 - 440 Hz

Before connecting to a mains outlet or power source, ensure that the ON/OFF switch is set to OFF and verify that the power cord and extension cord are compatible with the voltage/current range and that the circuit capacity is sufficient. Once the checks are done, connect the cable firmly.

The mains power cord included in the package is certified for use with this instrument. To change or add an extension cable, make sure that it meets the power requirements of this instrument. Any use of unsuitable or dangerous cables will void the warranty.

## 1. DELIVERY CONDITION

---

Check to make sure that all the items you ordered have been supplied.

Delivered in a cardboard box with:

- 1 Quick start guide paper
- 1 user's manual in pdf on website
- 1 PC software SX-GENE on website
- 1 multilingual safety sheet
- 1 compliance attestation
- A power cord that fits the standards 2p+T
- 1 USB cable.

For accessories and spares, visit our web site:

[www.chauvin-arnoux.com](http://www.chauvin-arnoux.com)



## 2. PRESENTATION

The **GX 1030** is a dual-channel function/arbitrary waveform generator with specifications of up to 30 MHz maximum bandwidth, 150 MSa/s sampling rate and 14-bit vertical resolution.

The proprietary EasyPulse technology helps to solve the weaknesses inherent in traditional DDS generators when generating pulse waveforms, and the special square wave generator is capable of generating square waveforms with up to 30 MHz frequency and low jitter.

With these advantages, **GX 1030** can provide users with a variety of high fidelity and low jitter signals and can meet the growing requirements of complex and extensive applications.

### 2.1. KEY FEATURES

- Dual-channel, with bandwidth up to 30 MHz and amplitude up to 20 Vpp
- 150 MSa/s sampling rate, 14-bit vertical resolution, and 16 kpts waveform length
- Innovative Easy Pulse technology, capable of generating lower jitter
- Pulse waveforms, brings a wide range and extremely high precision in pulse width and rise/fall times adjustment
- Special circuit for a Square wave, which can generate Square wave with frequencies up to 60 MHz and jitter less than 300 ps + 0.05 ppm of period
- A variety of analog and digital modulation types: AM, DSB-AM, FM, PM, FSK, ASK, PSK and PWM
- Sweep and Burst functions
- Harmonic waveforms generating function
- Waveforms combining function
- High precision Frequency Counter
- 196 kinds of built-in arbitrary waveforms
- Standard interfaces: USB Host, USB Device(USBTMC), LAN (VXI-11)
- LCD 4.3" display 480X272 points

### 2.2. OUTPUT CONNECTIONS

The function generator output circuits operate as a voltage source with an impedance of 50 ohms. At higher frequencies, an incorrectly loaded output can cause errors without the output waveform. In addition, loads with an impedance less than 50 ohms will reduce the amplitude of the waveform while loads with an impedance greater than 50 ohms will increase the amplitude of the waveform.

Excessive distortion or errors caused by incorrect terminators are less noticeable at low frequencies, especially with sinusoidal or triangular waveforms. Follow these precautions to ensure the integrity of the waveform :

- Use 50  $\Omega$  coaxial cables and good quality connectors.
- Make all connections as short as possible.
- Use good attenuators, if necessary, to reduce the amplitudes of waveforms applied to sensitive circuits.
- Use 50  $\Omega$  terminations or suitable impedance devices to avoid reflection.
- Make sure that attenuators and terminators can withstand the proper power.

If there is a DC voltage in the output load, use a serial coupling capacitor with the load. The time constant of the coupling capacitor and the load must be long enough to maintain the pulse plateau.

### 2.3. IMPEDANCE ADAPTATION

If the wave generator is connected to a high impedance, such as an input impedance of 1 M $\Omega$  (in parallel with a capacitor) at the input of an oscilloscope, connect the coaxial cable to a 50 attenuator, to a 50  $\Omega$  terminator and the oscilloscope. The attenuator isolates the input capacity of the device and allows a correct adaptation of the output of the generator.

# 3. DESCRIPTION OF THE INSTRUMENT

## 3.1. GETTING STARTED

### 1. Check Power Supply

Make sure that the supply voltage is correct before turning on the instrument. The supply voltage range shall comply with the specifications.

### 2. Power Supply Connection

Connect the power cord to the receptacle on the rear panel and press the ON switch to turn on the instrument. A start screen will appear on the screen during initialization followed by the main screen display.

### 3. Auto Check

Press Utility, and select the Test/Cal option.



Then select the SelfTest option. The device has 4 automatic test options: check the screen, keys, LEDs and internal circuits.



### 4. Output Check

Follow the steps below to perform a quick check of settings and output signals.

Turn the device on and set it to the default settings. To do this, press Utility, then System, then Set To Default.

1. Connect the BNC output of CH1 (green) to an oscilloscope.
2. Press the Output key on the BNC output of CH1 to start the output and observe a wave according to the above parameters.
3. Press the Parameter key.
4. Press Freq or Period in the menu and change the frequency using the numeric keypad or rotary button. Observe the change on the scope display.
5. Press Amplitude and use the rotary button or numeric keyboard to change the amplitude. Observe the change on the scope display.
6. Press DC Offset and use the rotary button or numeric keyboard to change the Offset DC. Observe the changes on the display when the scope is set for DC coupling.
7. Now connect the CH2 (yellow) BNC output to an oscilloscope and follow steps 3 and 6 to control its output. Use CH1/CH2 to switch from one channel to another.

### 3.2. HANDLE ADJUSTMENT

To adjust the handle position of the **GX 1030**, please grip the handle by the sides and pull it outward. Then, rotate the handle to the desired position.

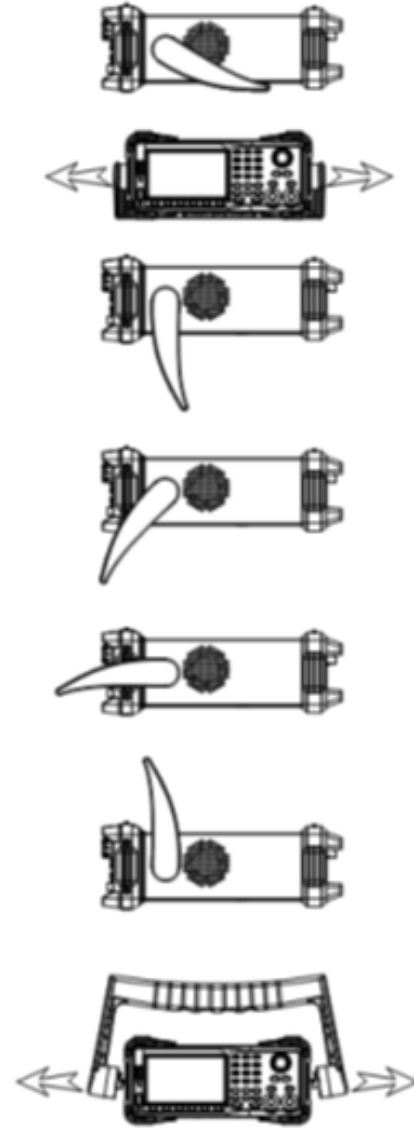

Figure 1: Viewing Position and Carrying Position



### 3.3. THE FRONT/REAR PANEL AND USER INTERFACE

This chapter will provide a brief introduction and description for the operation and functions of the front/rear panel.

The **Front Panel GX 1030** has a clear and simple front panel which includes a 4.3 inch screen, menu softkeys, numeric keyboard, knob, function keys, arrow keys and channel control area.

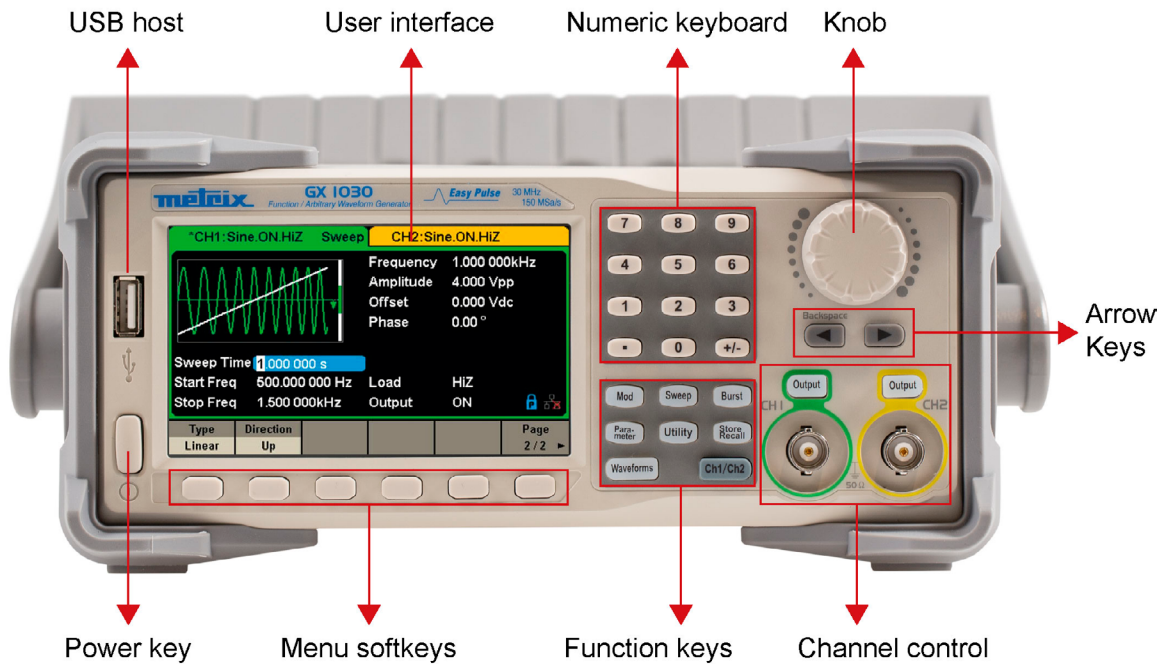

Figure 2: Front Panel of GX 1030

The **Rear Panel** provides multiple interfaces, including Counter, 10 MHz In/Out, Aux In/Out, LAN, USB Device, Earth Terminal and AC Power Supply Input.

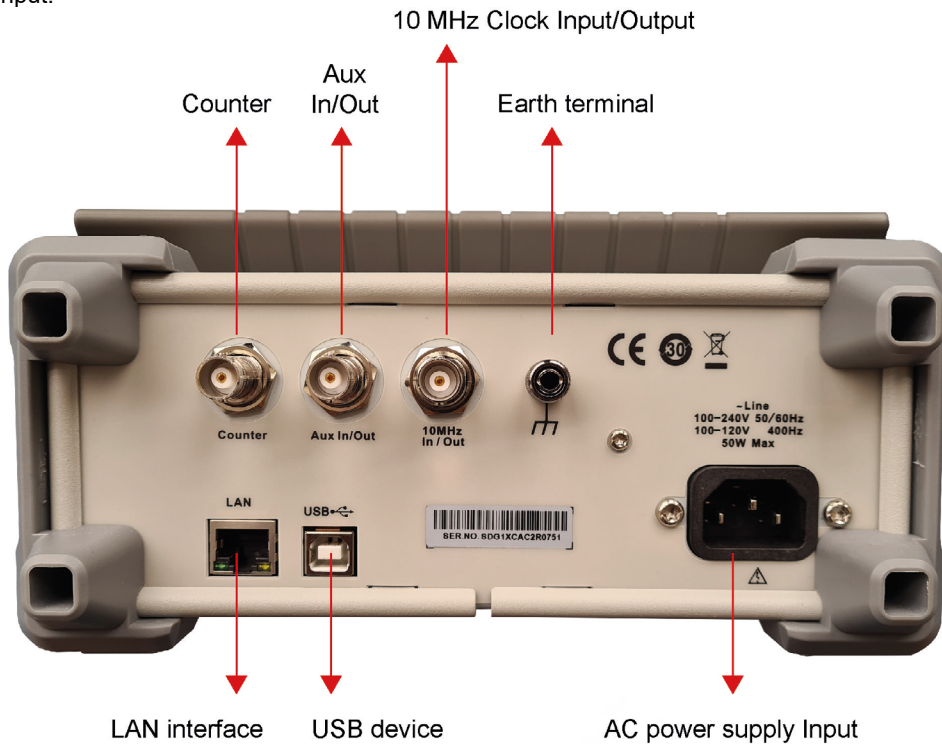
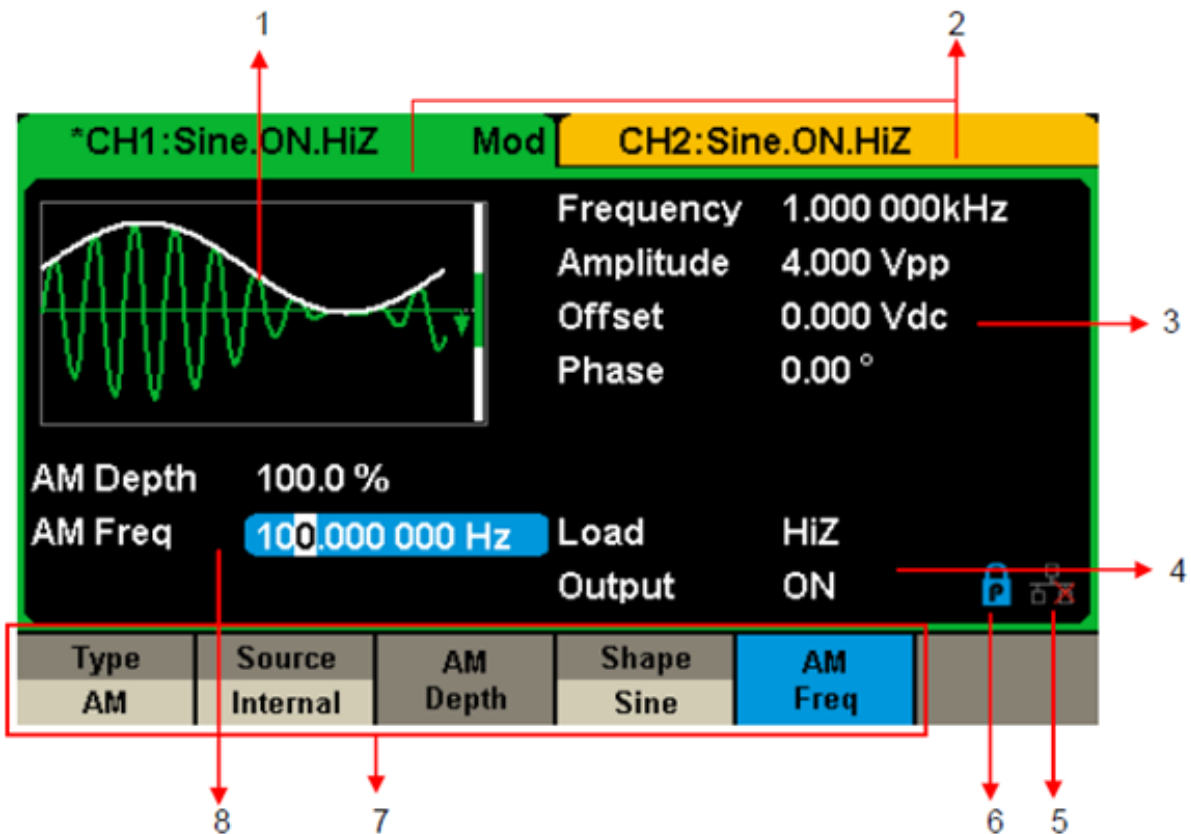

Figure 3: Rear Panel of GX 1030

**User Interface**

**GX 1030** can only display parameters and waveform information for one channel at a time.

The picture below shows the interface when CH1 chooses AM modulation of a sine waveform. The information displayed may vary depending on the function selected



**Figure 4: User Interface**

**1. Waveform Display Area**

Displays the currently selected waveform of each channel.

**2. Channel Status Bar**

Indicates the selected status and output configuration of the channels.

**3. Basic Waveform Parameters Area**

Shows the current waveform's parameters of each channel. Press Parameter and select the corresponding softkey to highlight the parameter to configure. then use number keys or knob to change the parameter value.

**4. Channel Parameters Area**

Displays the load and output load, as selected by the user.

**Load** ---- Value of the output load, as selected by the user.

Press Utility → Output → Load, then use the softkeys, number keys or knob to change the parameter value; or continue pressing the corresponding output key for two second to switch between High Impedance and 50 Ω.

High Impedance: display HiZ

**Load:** display impedance value (the default is 50 Ω and the range is 50 Ω. to 100 kΩ).

**Note:** This setting does not actually change the instrument's output impedance of 50 Ω but rather is used to maintain amplitude accuracy into different load values.

**Output:** Channel output state.

After pressing corresponding channel output control port, the current channel can be turned on/off.

**5. LAN Status icon**

**GX 1030** will show different prompt messages based on the current network status.



This mark indicates LAN connection is successful.



This mark indicates there is no LAN connection or LAN connection is unsuccessful.

**6. Mode Icon**



This mark indicates current mode is Phase-locked.



This mark indicates current mode is Independent.

**7. Menu**

Shows the menu corresponding to the displayed function. For example, Figure 4 shows the parameters of AM modulation.

**8. Modulation Parameters Area**

Shows the parameters of the current modulation function. After selecting the corresponding menu, use number keys or knob to change the parameter value.

## 4. FUNCTIONAL DESCRIPTION

### 4.1. TO SELECT THE WAVEFORM

Press **[Waveforms]** to enter the menu as Figure 5 shows. The example below will help familiarize with the waveform selection settings.

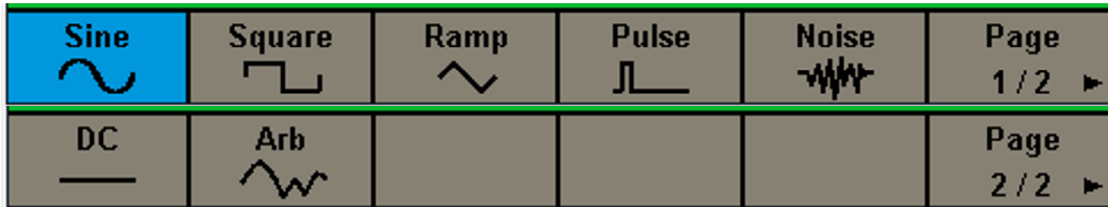

**Figure 5 Waveform Selections**

1. Press **[Waveforms]** key and then press **[Sine]** softkey. The **GX 1030** can generate sine waveforms with frequencies from 1  $\mu$ Hz to 30 MHz. By setting Frequency/Period, Amplitude/High level, Offset/Low level and Phase, a sine waveform with different parameters can be generated

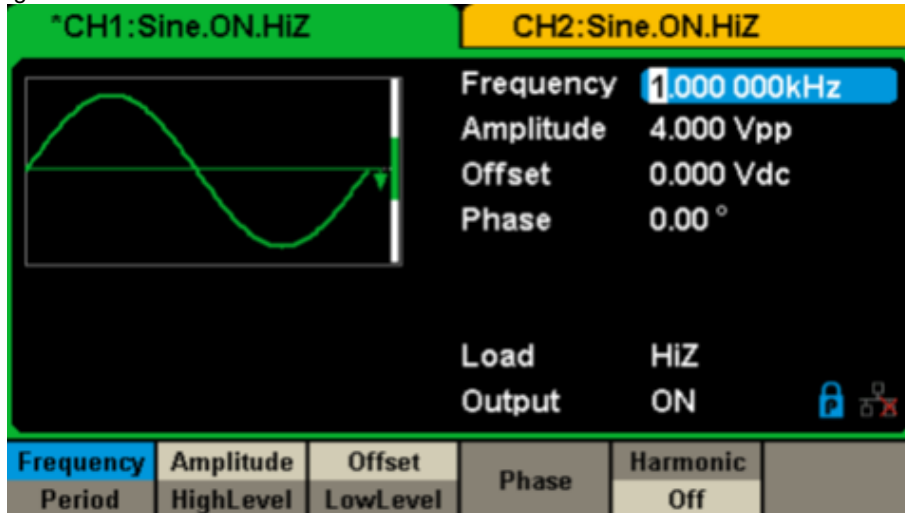

**Figure 6: Sine Display Interface**

2. Press **[Waveforms]** key and then press **[Square]** softkey. The generator can generate square waveforms with frequencies from 1  $\mu$ Hz to 30 MHz and variable duty cycle. By setting Frequency/Period, Amplitude/High level, Offset/Low level, Phase and DutyCycle, a square waveform with different parameters can be generated

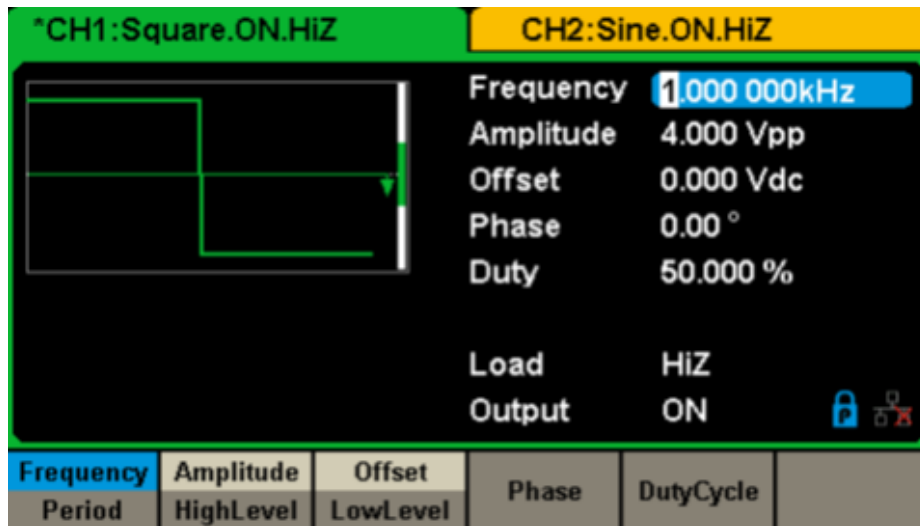

Figure 7: Square Display Interface

3. Press **[Waveforms]** key and then press **[Ramp]** softkey. The generator can generate ramp waveforms with frequencies from 1  $\mu$ Hz to 500 kHz and variable symmetry. By setting Frequency/Period, Amplitude/High level, Offset/Low level, Phase and Symmetry, a ramp waveform with different parameters can be generated.

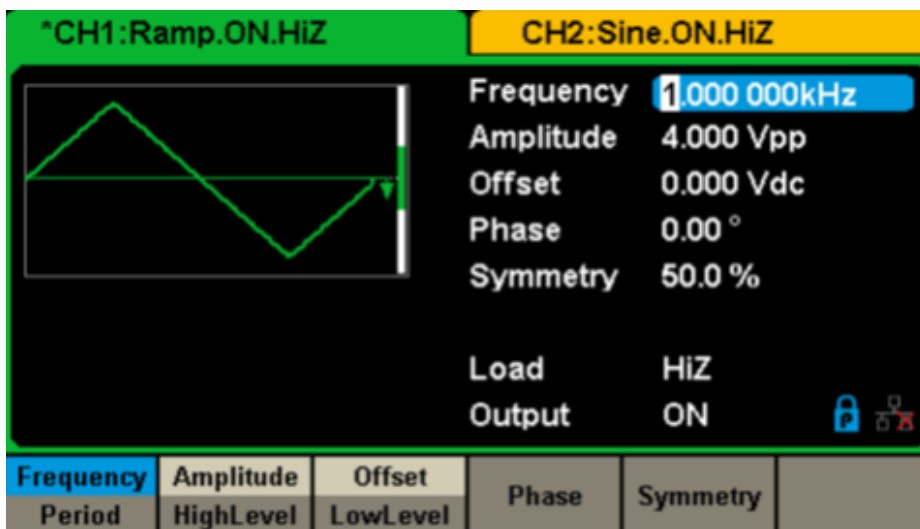

Figure 8: Ramp Display Interface

4. Press **[Waveforms]** key and then press **[Pulse]** softkey. The generator can generate pulse waveforms with frequencies from 1  $\mu$ Hz to 12.5 MHz and variable pulse width and rise/fall times. By setting Frequency/Period, Amplitude/High level, Offset/Low level, PulWidth/Duty, Rise/Fall and Delay, a pulse waveform with different parameters can be generated.

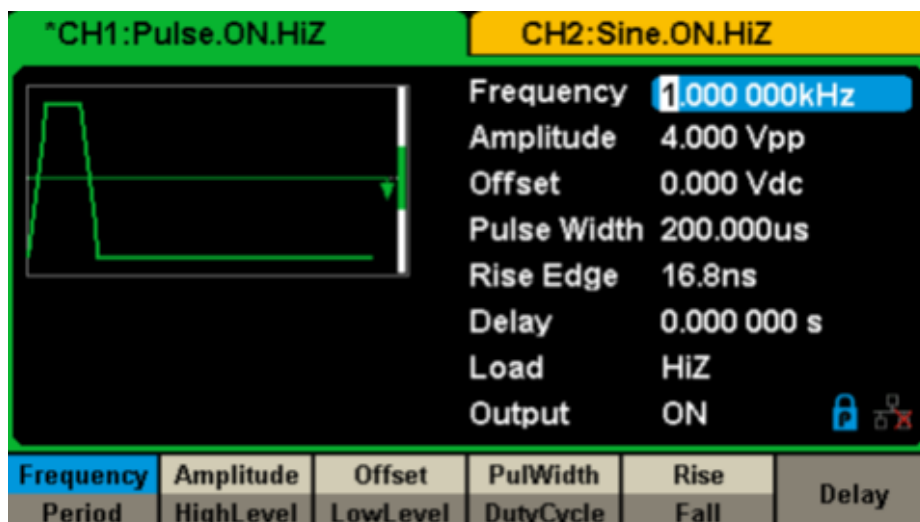

Figure 9: Pulse Display Interface

5. Press **[Waveforms]** key and then press **[Noise Stdev]** softkey. The generator can generate noise with a 60 MHz bandwidth. By setting Stdev and Mean, noise with different parameters can be generated.

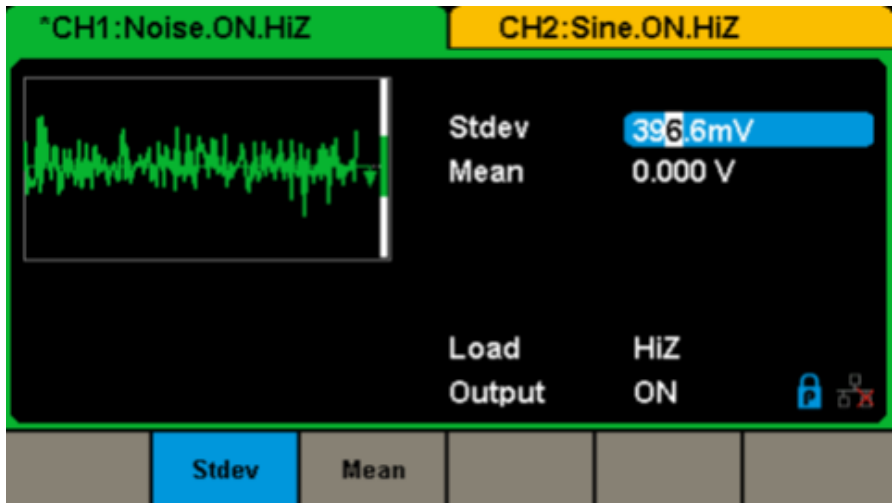

Figure 10: Noise Display Interface

6. Press **[Waveforms]** key and then press **[Page 1/2]**, last press the DC softkey. The generator can generate a DC signal with a level up to  $\pm 10$  V into a HighZ load or  $\pm 5$  V into a 50  $\Omega$  load.

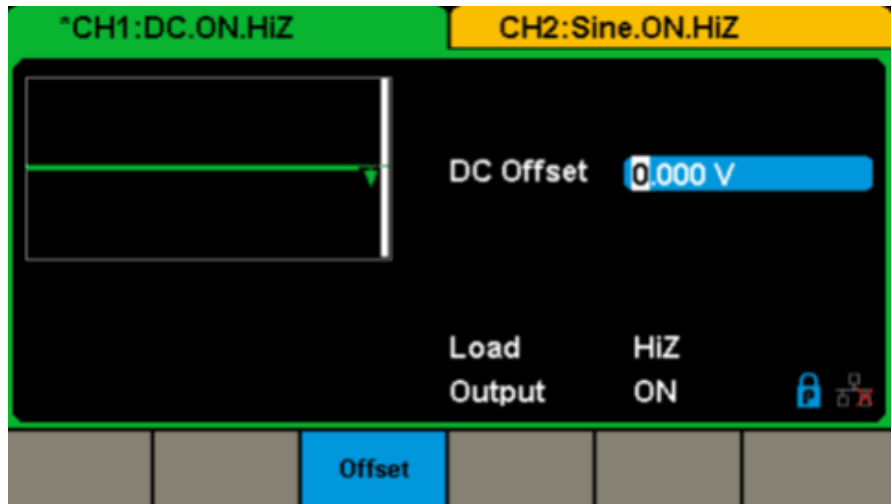

Figure 11: DC Display Interface

7. Press **[Waveforms]** key and then press **[Page 1/2]**, lastly press the **[Arb]** softkey. The generator can generate repeatable arbitrary waveforms with 16 K points and frequencies up to 6 MHz. By setting Frequency/Period, Amplitude/High level, Offset/Low level and Phase, an arbitrary waveform with different parameters can be generated.

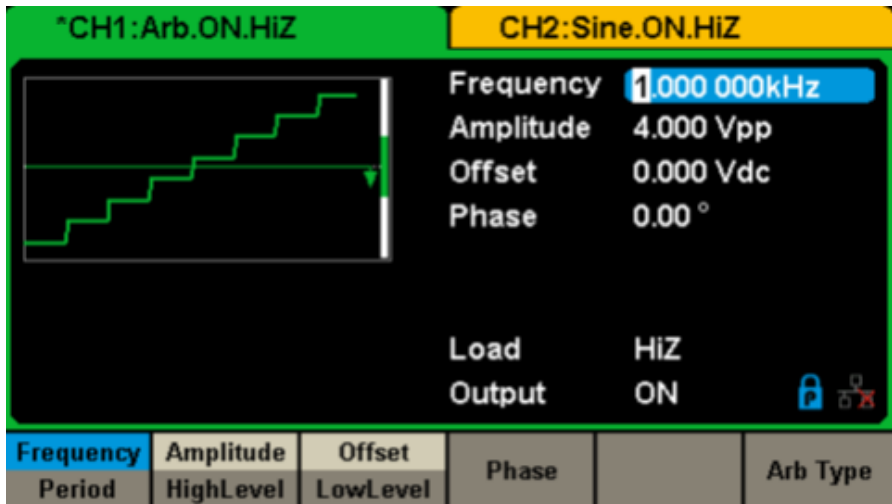

Figure 12: Arbitrary Waveform Display Interface

## 4.2. TO SET MODULATION/SWEEP/BURST

As shown in Figure 13, there are three keys on the front panel which are used for modulation, sweep and burst settings. The instructions below will help to explain these functions.

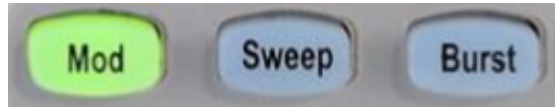

Figure 13: Modulate/Sweep/Burst Key

1. Press **[Mod]**, the **Modulation** function will be enabled.

The modulated waveform can be changed by modifying the parameters such as **Type**, Source, AM Depth, AM Freq, Shape, etc.

The **GX 1030** can modulate waveforms using AM, FM, PM, ASK, FSK, PSK, PWM and DSB-AM, etc. Pulse waveforms can only be modulated using PWM. Noise and DC waveforms cannot be modulated.

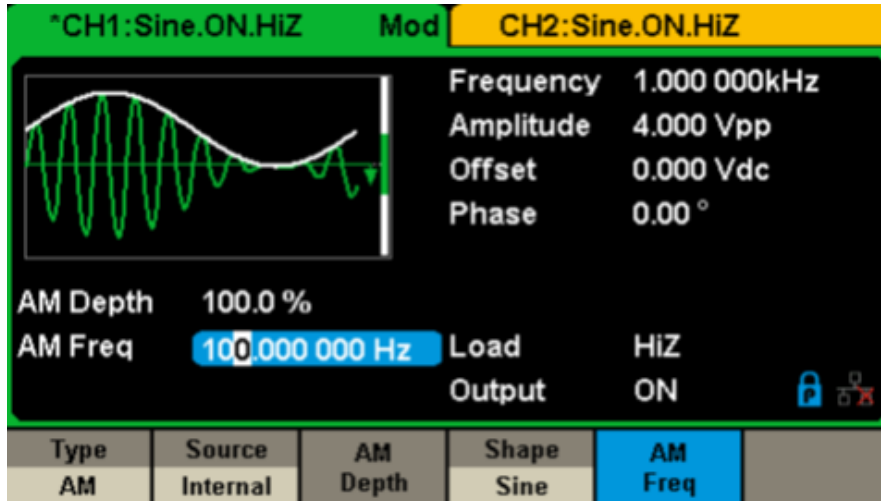

Figure 14: Modulation Display Interface

2. Press **[Sweep]**, the Sweep function will be enabled.

Sine, square, ramp and arbitrary waveforms support the sweep function. In sweep mode, the **GX 1030** can generate signals with variable frequency.

The available range of sweep time is from 1 ms to 500 s. The trigger source can be Internal, External or Manual.

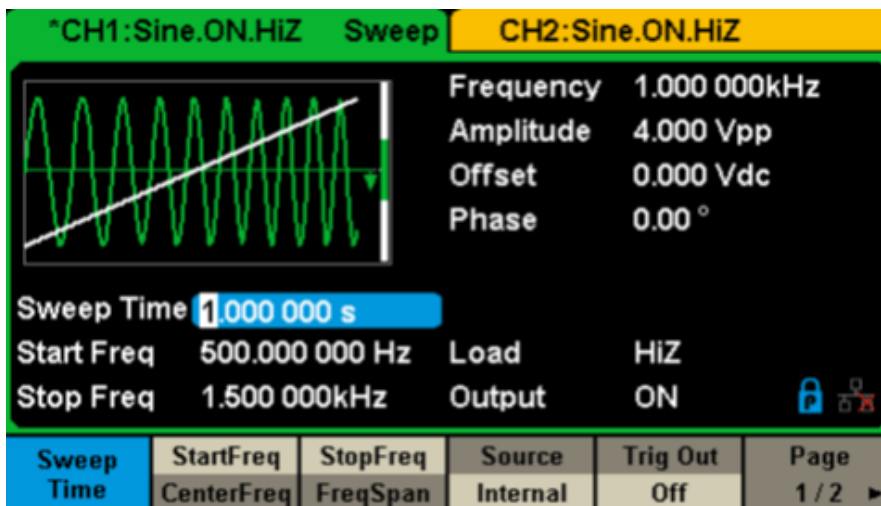

Figure 15: Sweep Waveform Display Interface

3. Press **[Burst]**, the Burst function will be enabled.

Burst signals for sine, square, ramp, pulse or arbitrary waveforms may be generated. Start Phase ranges from 0° to 360° and Burst Period ranges from 1 μs to 1000 s.

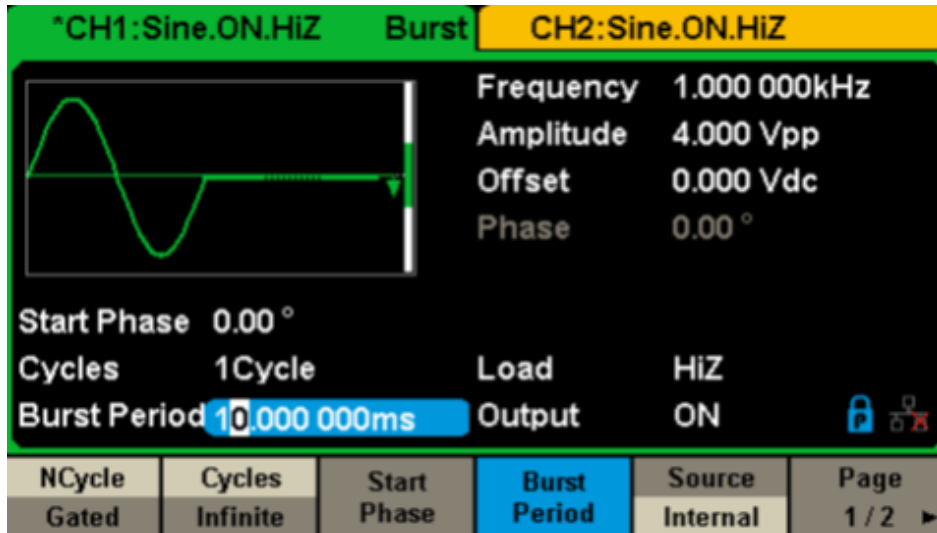

Figure 16: Burst Waveform Display Interface

### 4.3. TO TURN ON/OFF OUTPUT

As shown in Figure 17, there are two keys on the right side of the operation panel which are used to enable / disable the output of the two channels. Choose a channel and press the corresponding Output key, the key backlight will be lighted and the output will be enabled. Press the Output key again, the key backlight will be extinguished and the output will be disabled. Keep pressing the corresponding output key for two seconds to switch between High Impedance and 50  $\Omega$  load.



Figure 17: Output Keys

### 4.4. TO USE NUMERIC INPUT

As shown in



Figure 18: Front Panel Digital Input

There are three sets of keys on the front panel, which are arrow keys, knob and numeric keyboard.

The instructions below will help to familiarize you with the digital input selection.

1. The numeric keyboard is used to enter the parameter's value.
2. The knob is used to increase (clockwise) or decrease (counterclockwise) the current digit when setting parameters.
3. When using knob to set parameters, the arrow keys are used to select the digit to be modified.  
When using numeric keyboard to set parameters, the left arrow key is used as a Backspace function.

## 4.5. TO USE COMMON FUNCTION KEYS

As shown in Figure 19, there are five keys on the operation panel which are labeled [Parameter], [Utility], [Store/Recall], [Waveforms], and [Ch1/Ch2]. The instructions below will help to familiarize you with these functions.



**Figure 19: Waveforms Utility and Parameter Key**

1. The **Parameter** key makes it convenient for the operator to set the parameters of basic waveforms directly.
2. The **Utility** key is used to set the auxiliary system function, such as output configurations, interface setting, system setting information, performing the instrument self-test and reading the calibration information, etc.
3. The **Store/Recall** key is used to store and recall waveform data and configuration information.
4. The **Waveforms** key is used to select basic waveforms.
5. The **Ch1/Ch2** key is used to switch the currently selected channel between CH1 and CH2. After start-up, CH1 is selected as default. At this point, press the key to select CH2.



# 5. FUNCTIONAL DESCRIPTION

## HOW TO MEASURE THE DIFFERENT WAVEFORMS ?

### 5.1. TO SET SINE WAVEFORM

Press **[Waveforms]** key to select the **waveform** function and then press the **[Sine softkey]**. The sine waveform parameters are set by using the sine operation menu.

The parameters available for sine waveforms include frequency/period, amplitude/high level, offset/low level and phase. Different sine signals can be generated by setting these parameters.

As shown in Figure 20, in the soft key menu, select Frequency. The frequency parameter area is highlighted in the parameter display window, and users can set the frequency value here.

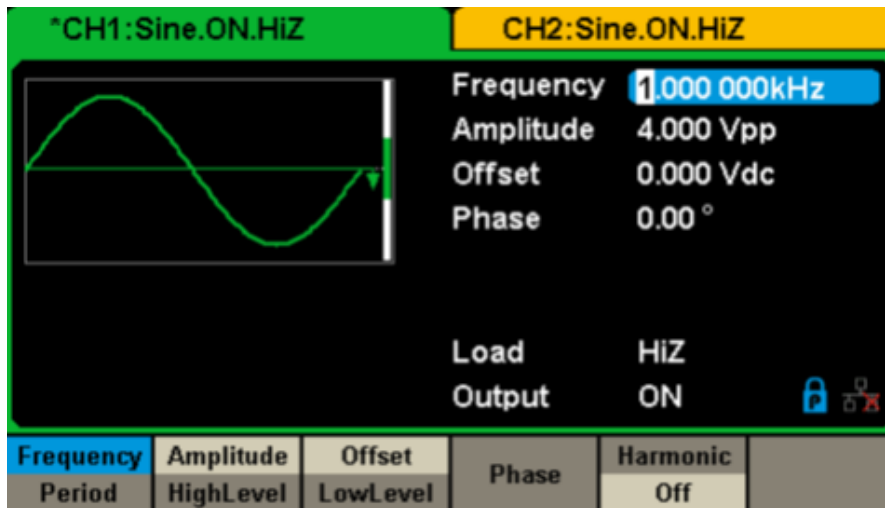

Figure 20: Sine Parameters Display Interface

Function menu	Explanations
Frequency / Period	Set the signal frequency or period. The current parameter will be switched with a second press.
Amplitude / HighLevel	Set the signal amplitude or high level. The current parameter will be switched with a second press.
Offset/LowLevel	Set the signal offset or low level. The current parameter will be switched with a second press.
Phase	Set the phase of the signal.

#### Menu Explanations of Sine Waveform

##### To Set the Frequency/Period

Frequency is one of the most important parameters of basic waveforms. For different instrument models and waveforms, the available ranges of frequency are different.

For detailed information, please refer to specifications.

The default frequency is 1 kHz.

1. Press **[Waveforms]** → **[Sine]** → **[Frequency]**, to set the frequency parameter.

The frequency shown on the screen when the instrument is powered on is the default value or the set value of last power down. If Period (rather than Frequency) is the desired parameter, press Frequency/Period again to enter the Period mode. The current value for the waveform's period is now displayed in inverse color. Press the Frequency/Period key once again to return to the Frequency entry mode.

##### 2. Input the desired frequency.

Use the numeric keyboard to input the parameter value directly, and press the corresponding key to select the parameter unit. Or use the arrow keys to select the digit to edit, and then use the knob to change its value.

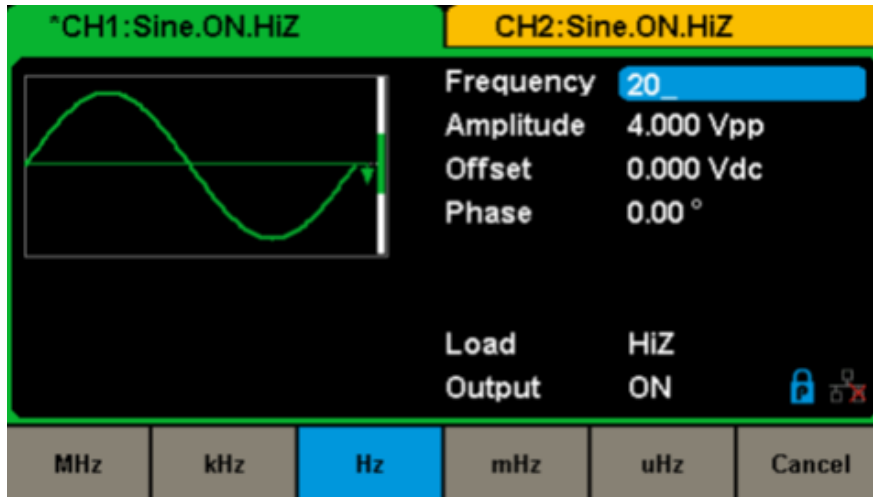

Figure 21: Setting the Frequency

**Note:** When using the numeric keyboard to enter the value, the left arrow key can be used to move the cursor backward and delete the value of the previous digit.

**To Set the Amplitude**

The amplitude setting range is limited by the Load and Frequency/Period settings. For detailed information, please refer to specifications.

1. Press **[Waveforms]** → **[Sine]** → **[Amplitude]**, to set the amplitude.

The amplitude shown on the screen when the instrument is powered on is the default value or the set value of last power down. If setting the waveform's high level is desired, press the Amplitude/HighLevel key again to switch into the high level parameter (the current operation is displayed in inverse color).

2. Input the desired amplitude.

Use the numeric keyboard to input the parameter value directly, and press the corresponding key to select the parameter unit. Or use the arrow keys to select the digit to edit, and then use the knob to change its value

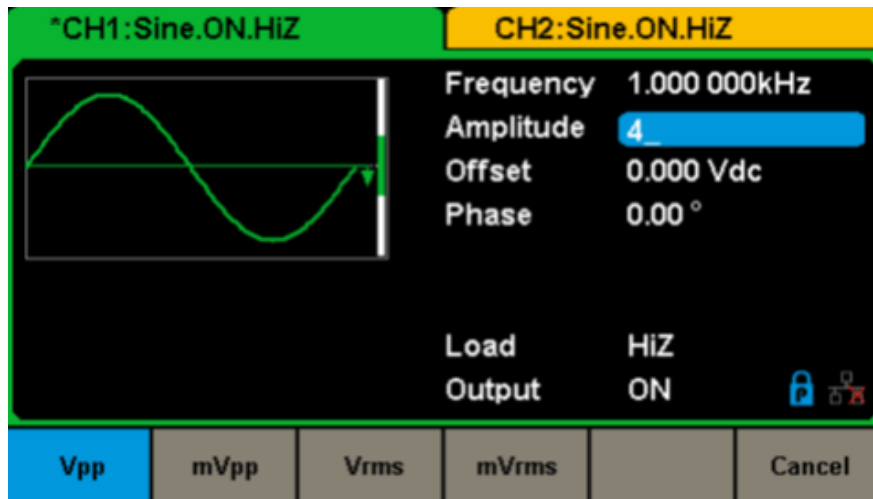

Figure 22: Setting the Amplitude

**To Set the Offset**

The offset setting range is limited by the **Load** and **Amplitude/HighLevel** settings. For detailed information, please refer to specifications. The fault value is 0 VDC.

1. Press **[Waveforms]** → **[Sine]** → **[Offset]**, to set the offset.

The offset shown on the screen when the instrument is powered on is the default value or the set value of last power down. If you want to set the waveform by low level, press the Offset/LowLevel key again, to switch into the low level parameter (the current operation is displayed in inverse color).

2. Input the desired offset.

Use the numeric keyboard to input the parameter value directly, and press the corresponding key to select the parameter unit. Or use the arrow keys to select the digit to edit, and then use the knob to change its value.

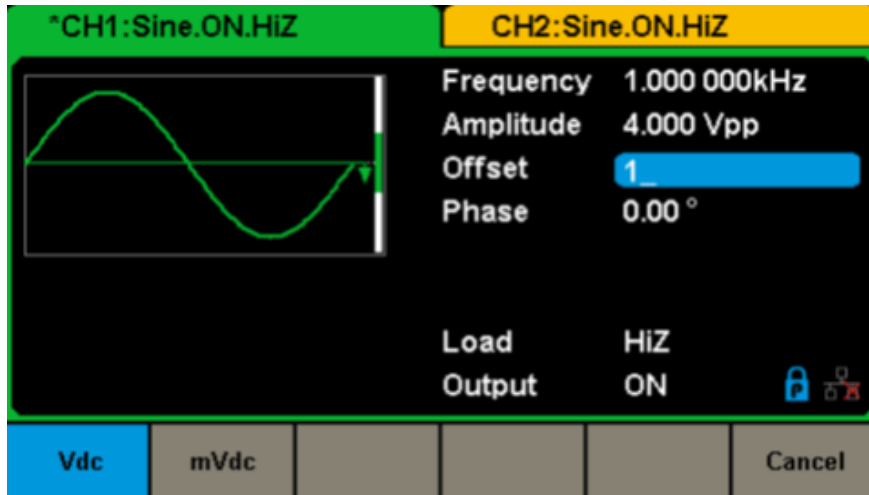

Figure 23: Setting the Offset

**To Set the Phase**

1. Press **[Waveforms]** → **[Sine]** → **[Phase]**, to set the phase.

The Phase shown on the screen when the instrument is powered on is the default value or the set value of last power down.

2. Input the desired phase.

Use the numeric keyboard to input the parameter value directly and press the corresponding key to select the parameter unit. Or use the arrow keys to select the digit to edit, and then use the knob to change its value.

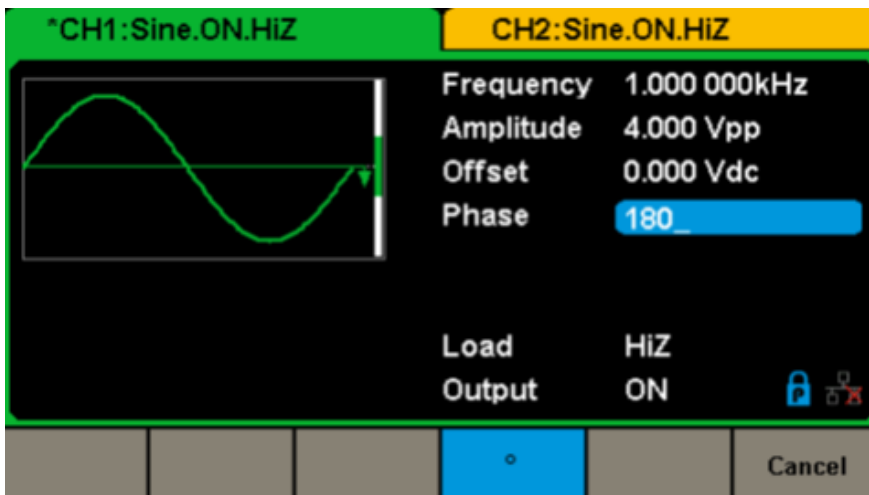

Figure 24: Setting the Phase

**Note:** When the independent mode is enabled, the phase parameter cannot be modified.

## 5.2. TO SET SQUARE WAVEFORM

Press **[Waveforms]** key to select the waveform function, and press the **[Square]** softkey.

The square waveform parameters are set by using the Square operation menu.

The parameters of square waveforms include frequency/period, amplitude/high level, offset/low level, phase and duty. As shown in Figure 25, select DutyCycle.

The duty cycle parameter area is highlighted in the parameter display window, and users can set the duty cycle value here.

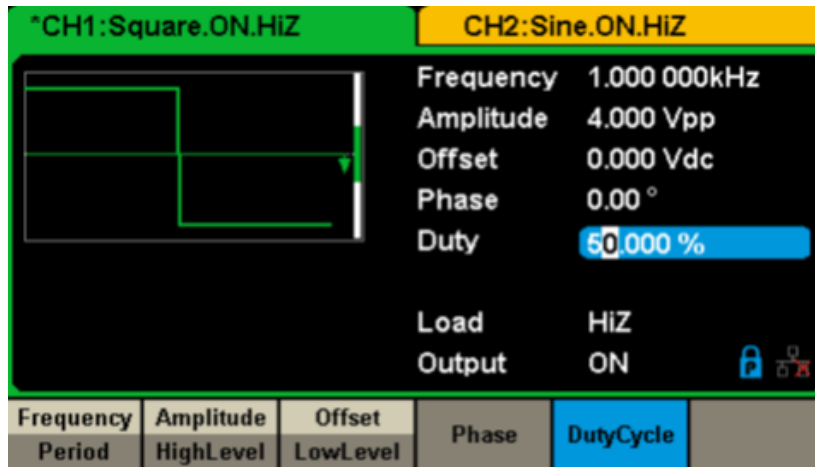

Figure 25: Square Parameters Display Interface

Function menu	Explanations
Frequency / Period	Set the signal frequency or period. The current parameter will be switched with a second press.
Amplitude / HighLevel	Set the signal amplitude or high level. The current parameter will be switched with a second press.
Offset/LowLevel	Set the signal offset or low level. The current parameter will be switched with a second press.
Phase	Set the phase of the signal.
DutyCycle	Set the duty cycle for square waveform

### Menu Explanations of Square Waveform

#### To Set the Duty Cycle

**Duty Cycle:** The ratio of the amount of time the pulse is in the high state and the waveform's period.

The **Duty Cycle** setting range is limited by the Frequency/Period setting.

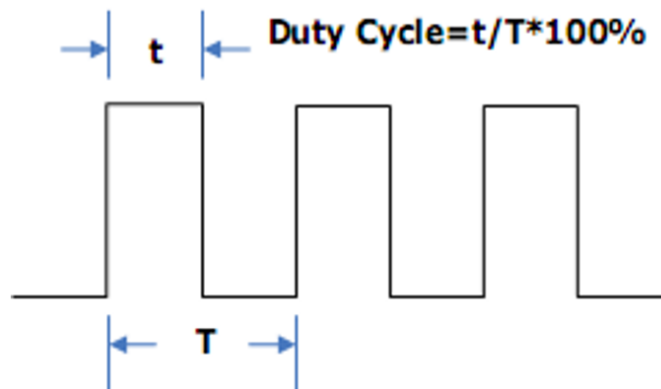

For detailed information, please refer to specifications.

The default value is 50 %

1. Press **[Waveforms]** → **[Square]** → **[DutyCycle]**, to set the duty cycle.

The duty cycle shown on the screen when the instrument is powered on is the default value or the set value of last power down.

2. Input the desired **Duty Cycle**.

Use the numeric keyboard to input the parameter value directly and press the corresponding key to select the parameter unit. Or use the arrow keys to select the digit to edit, and then use the knob to change its value. The generator will change the waveform immediately.

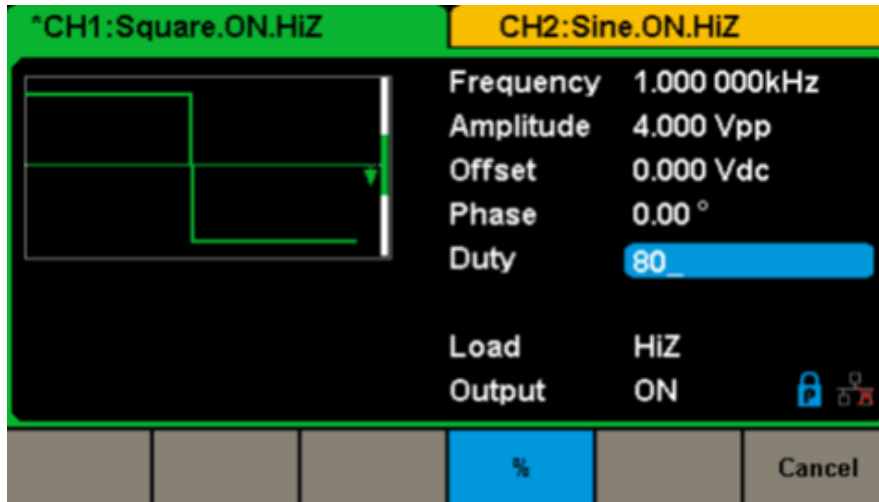

Figure 26: Setting the Duty Cycle

**Note:** The methods of setting other parameters of square signal are similar to sine waveform function.

### 5.3. TO SET RAMP WAVEFORM

Press **[Waveforms]** key to select the waveform function, and press the Ramp softkey. The ramp waveform parameters are set by using the ramp operation menu.

The parameters for ramp waveforms include frequency/period, amplitude/high level, offset/low level, phase and symmetry. As shown in Figure 27, in the soft key menu, select Symmetry.

The symmetry parameter area is highlighted in the parameter display window, and users can set the symmetry value here.

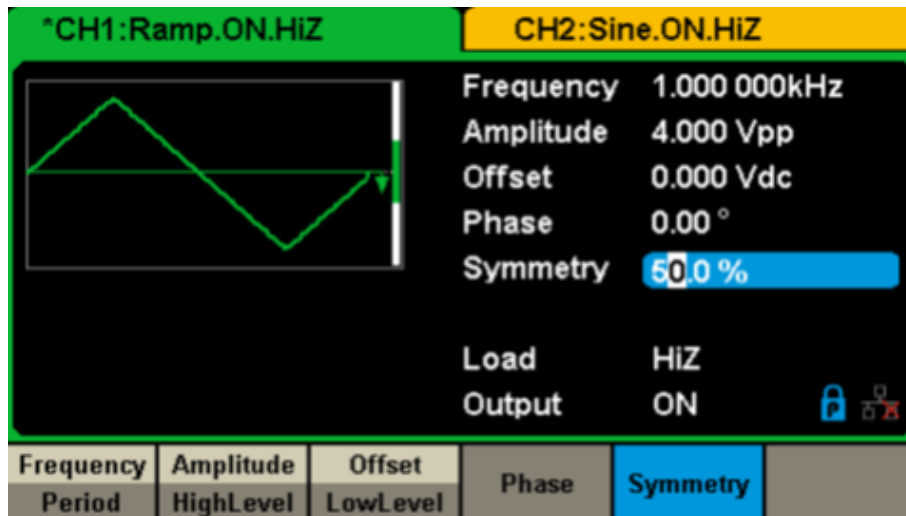

Figure 27: Ramp Parameters Display Interface

Function menu	Explanations
Frequency / Period	Set the signal frequency or period. The current parameter will be switched with a second press.
Amplitude / HighLevel	Set the signal amplitude or high level. The current parameter will be switched with a second press.
Offset/LowLevel	Set the signal offset or low level. The current parameter will be switched with a second press.
Phase	Set the phase of the signal.
Symmetry	Set the symmetry for ramp waveform

Menu Explanations of Ramp Waveform

**To Set the Symmetry:**

The percentage that the rising period takes up the whole Period.

**Input range:** 0 ~ 100 %

**Default Value:** 50 %

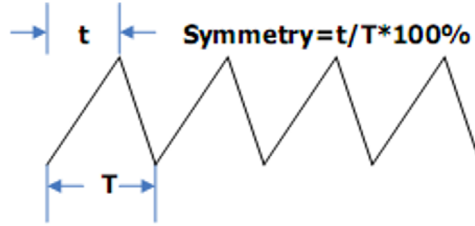

1. Press **[Waveforms]** → **[Ramp]** → **[Symmetry]**, to set the symmetry.

The symmetry shown on the screen when the instrument is powered on is the default value or the set value of the last power down.

2. Input the desired Symmetry.

Use the numeric keyboard to input the parameter value directly, and press the corresponding key to select the parameter unit. Or use the arrow keys to select the digit to edit, and then use the knob to change its value. The generator will change the waveform immediately.

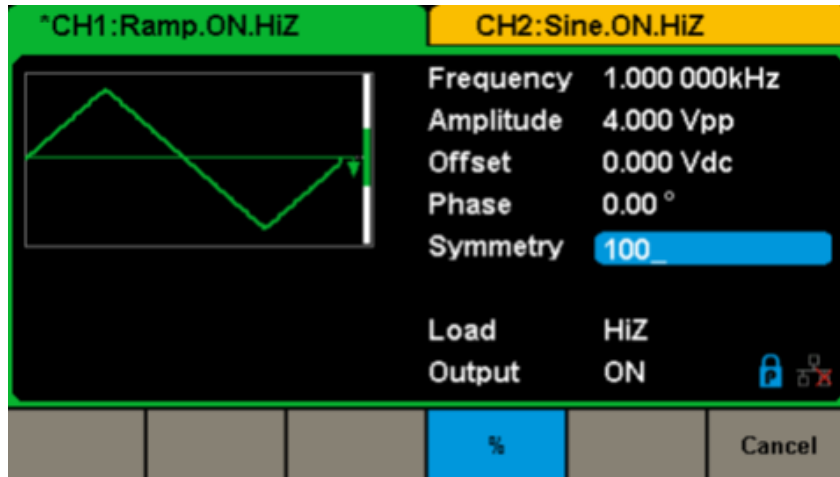

Figure 28: Setting Symmetry

**Note:** The methods of setting other parameters of ramp signal are similar to the sine waveform function.

### 5.4. TO SET PULSE WAVEFORM

Press **[Waveforms]** key to select the waveform function, and press the Pulse softkey. The pulse waveform parameters are set by using the pulse operation menu.

The parameters for pulse waveforms include frequency/period, amplitude/high level, offset/low level, width, rise/fall and delay. As shown in Figure 29, in the soft key menu, select PulWidth. The pulse width parameter area is highlighted in the parameter display window, and users can set the pulse width value here.

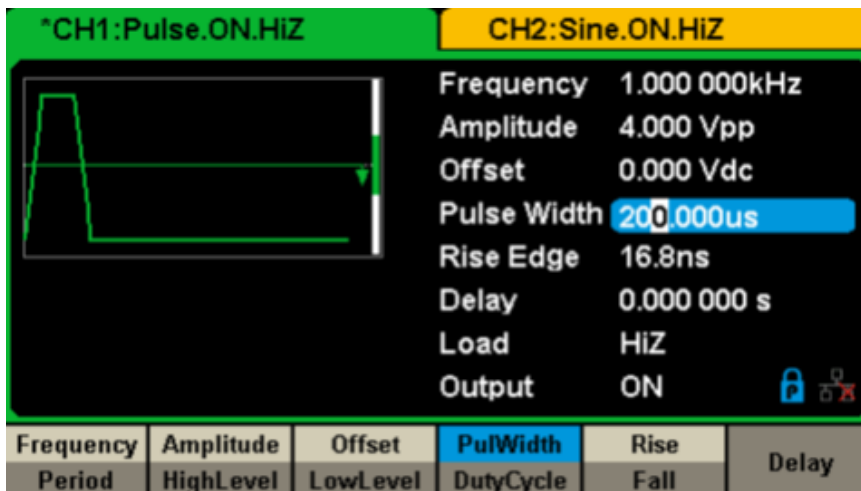

Figure 29: Pulse Parameters Display Interface

Function menu	Explanations
Frequency / Period	Set the signal frequency or period. The current parameter will be switched with a second press.
Amplitude / HighLevel	Set the signal amplitude or high level. The current parameter will be switched with a second press.
Offset/LowLevel	Set the signal offset or low level. The current parameter will be switched with a second press.
PulWidth/DutyCycle	Set the signal pulse width or duty cycle. The current parameter will be switched with a second press.
Rise/Fall	Setting the rise edge or fall edge for pulse waveform. The current parameter will be switched with a second press.
Delay	Setting the delay for pulse waveform.

### Menu Explanations of Pulse Waveform

#### To Set the Pulse Width/DutyCycle

Pulse width is defined as the time from the 50 % threshold of a rising edge amplitude to the 50 % threshold of the next falling edge amplitude (as shown in the figure below).

The pulse width setting range is limited by the **Minimum Pulse Width** and **Pulse Period** setting.

For detailed information, please refer to specifications.

The default value is 200  $\mu$ s. Pulse duty cycle is defined as the percentage that the pulse width takes up in the whole period. Pulse duty cycle and pulse width are correlative. Once a parameter is changed, the other will be automatically changed.

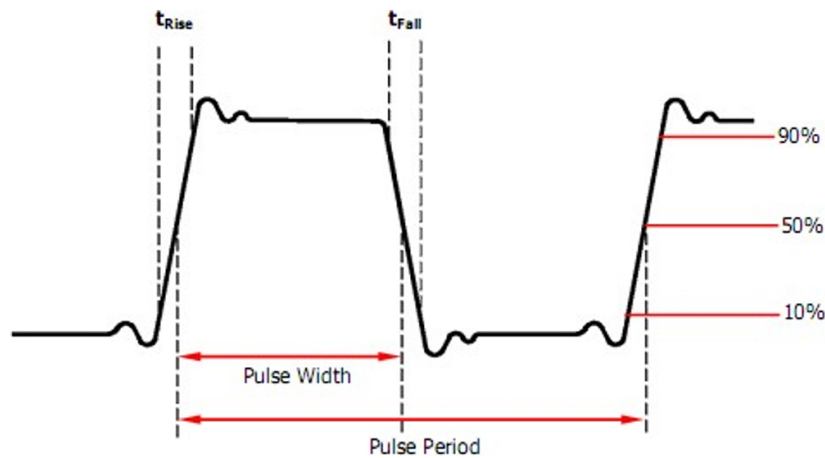

1. Press **[Waveforms]** → **[Pulse]** → **[PulWidth]**, to set the pulse width.

The pulse width shown on the screen when the instrument is powered on is the default value or the set value of last power down. If you want to set the waveform by duty, press the PulWidth/DutyCycle key again, to switch into the duty parameter (the current operation is displayed in inverse color).

2. Input the desired Pulse Width.

Use the numeric keyboard to input the parameter value directly, and press the corresponding key to select the parameter unit. Or use the arrow keys to select the digit to edit, and then use the knob to change its value.

The generator will change the waveform immediately.

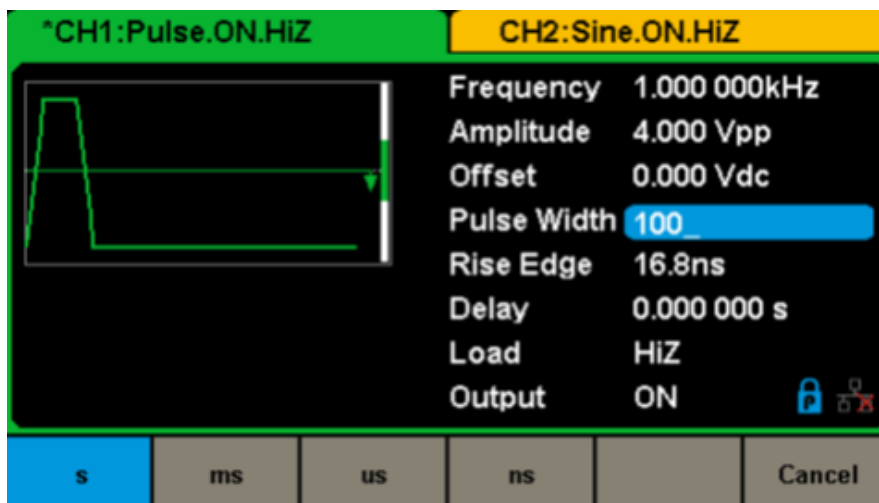

Figure 30: Setting the Pulse Width

### To Set the Rise/Fall Edge

Rise edge time is defined as the duration of the pulse amplitude rising from 10 % to 90 % threshold, while fall edge time is defined as duration of the pulse amplitude moving down from 90 % to 10 % threshold.

The setting of rise/fall edge time is limited by the currently specified pulse width limit. Users can set rise edge and fall edge independently.

1. Press **[Waveforms]** → **[Pulse]** → **[Rise]** to set the rise edge.

The rise edge shown on the screen when the instrument is powered on is the default value or the set value of the last power down. If you want to set the waveform by fall edge, press the Rise/Fall key again, to switch into the fall edge parameter (the current operation is displayed in inverse color).

2. Input the desired rise edge.

Use the numeric keyboard to input the parameter value directly, and press the corresponding key to select the parameter unit. Or use the arrow keys to select the digit to edit, and then use the knob to change its value. The generator will change the waveform immediately.

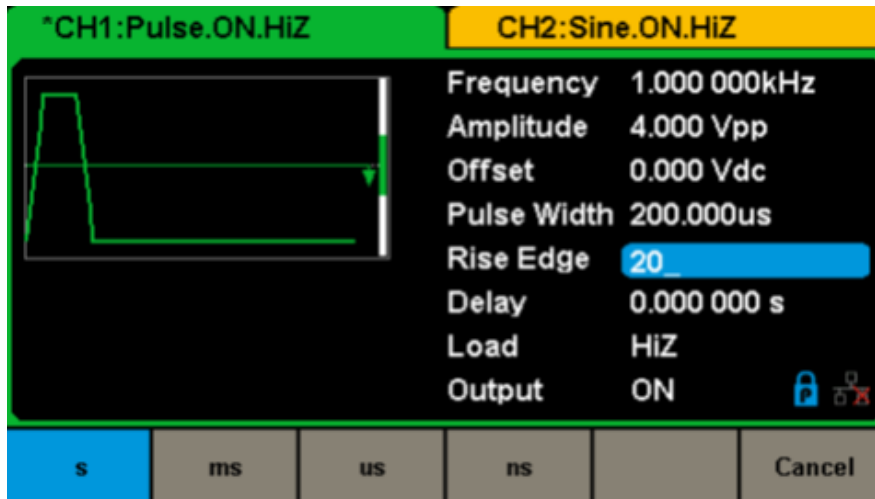

Figure 31: Setting the Rise Edge

**Note:** The methods of setting other parameters of the pulse signal are similar to the sine waveform function.

## 5.5. TO SET NOISE WAVEFORM

Press **[Waveforms]** key to select the waveform function, and press the **[Noise]** softkey. The noise parameters are set by using the noise operation menu.

The parameters for noise include **stdev**, mean and bandwidth. As shown in Figure 32, in the soft key menu, select Stdev. The stdev parameter area is highlighted in the parameter display window, and users can set the stdev value here. Noise is non-periodic signal which has no frequency or period.

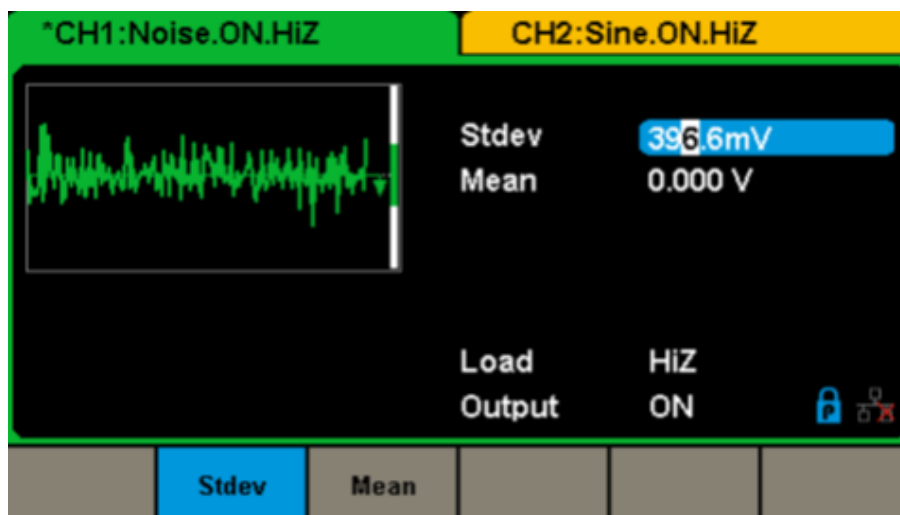

Figure 32: Noise Parameters Display Interface



Function menu	Explanations
Stdev	Setting the stdev for noise waveform.
Mean	Setting the mean for noise waveform

### Menu Explanations of Noise

#### To Set the Stdev

1. Press **[Waveforms]** → **[Noise]** → **[Stdev]**, to set the standard deviation.

The stdev shown on the screen when the instrument is powered on is the default value or the set value of last power down.

2. Input the desired **stdev**.

Use the numeric keyboard to input the parameter value directly, and press the corresponding key to select the parameter unit. Or use the arrow keys to select the digit to edit, and then use the knob to change its value.

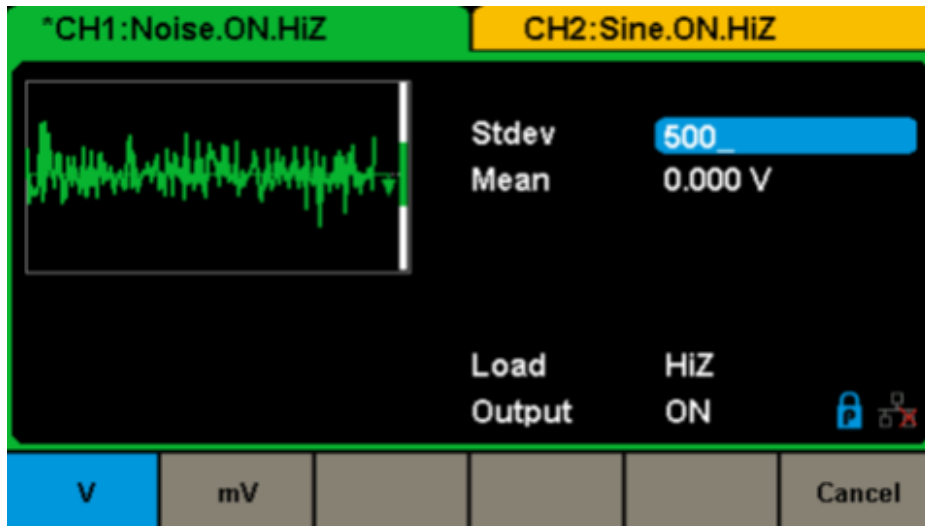

Figure 33: Setting the Stdev

#### To Set the Mean

1. Press **[Waveforms]** → **[Noise]** → **[Mean]**, to set the mean.

The mean shown on the screen when the instrument is powered on is the default value or the set value of the last power down.

2. Input the desired mean.

Use the numeric keyboard to input the parameter value directly, and press the corresponding key to select the parameter unit. Or use the arrow keys to select the digit to edit, and then use the knob to change its value.

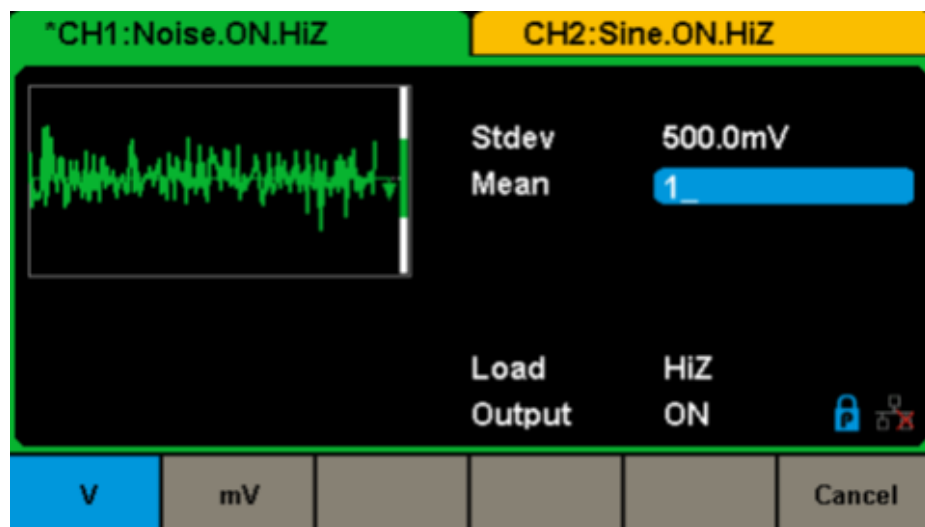

Figure 34: Setting the Mean

## 5.6. TO SET DC WAVEFORM

1. Press [Waveform] → [Page 1/2] → [DC], to enter the following interface.

Please note that there is a "DC offset" parameter in the middle of the screen.

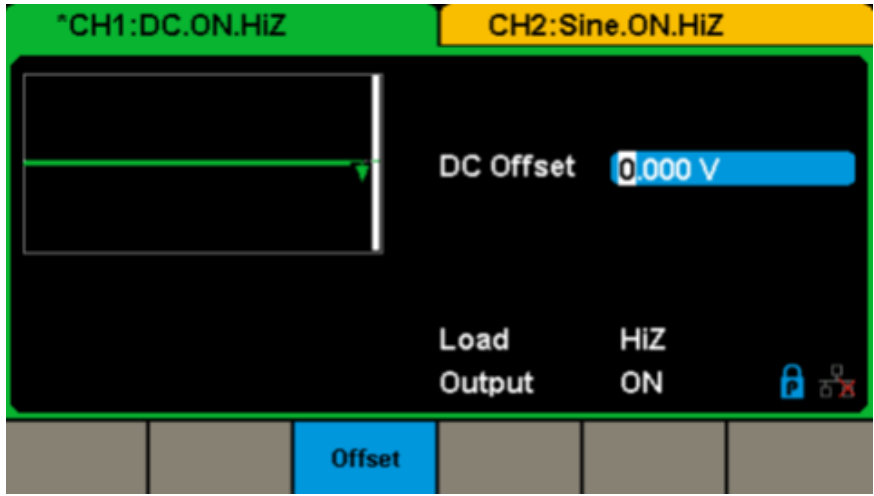

Figure 35: DC Setting Interface

## 5.7. TO SET ARBITRARY WAVEFORM

The Arb signal consists of two types: the system's built-in waveforms and the user-defined waveforms. Built-in waveforms are stored in the internal non-volatile memory. Users may also edit the arbitrary waveform with 16 K data points, namely 16 kpts. Choose [Waveforms] → [Page 1/2] → [Arb]. The parameters include frequency/period, amplitude/high level, offset/low level and phase.

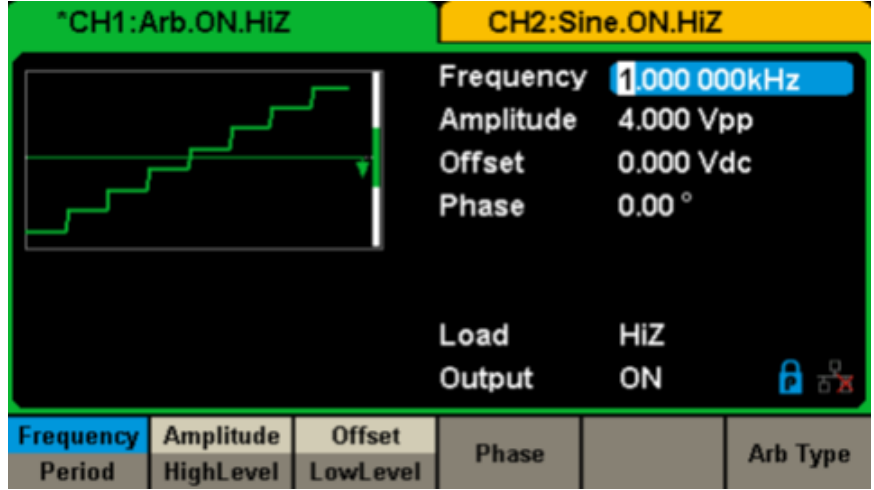

Figure 36: Arb Parameters Display Interface (DDS)

Function menu	Explanations
Frequency / Period	Set the signal frequency or period. The current parameter will be switched with a second press.
Amplitude / HighLevel	Set the signal amplitude or high level. The current parameter will be switched with a second press.
Offset/LowLevel	Set the signal offset or low level. The current parameter will be switched with a second press.
Phase	Set the phase of the signal

Menu Explanations of Arb Waveform (Page 1/2)

**Note:** The methods of setting the parameters of the arbitrary signal are similar to the sine waveform function.

### To select the built-in Arbitrary Waveform

There are plenty of built-in Arbitrary Waveforms and user-defined Arbitrary Waveforms inside the generator. To select one of them, follow the instructions below.

#### 1. To select the Built-in Waveform

Choose [Waveforms] → [Page 2/2] → [Arb] → [Arb Type] → [Buit-in] to enter the following interface, as shown in Figure 37.

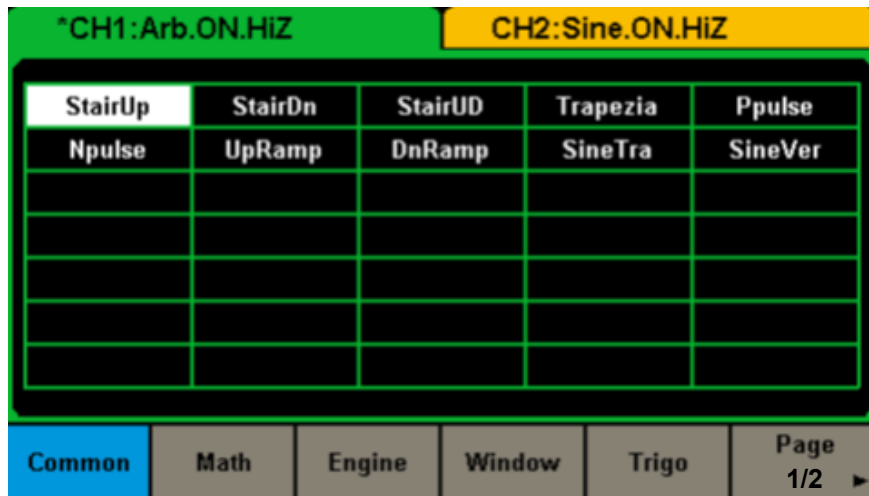

Figure 37: Built-in Arbitrary Waveforms

Press **Common**, **Math**, **Engine**, **Window**, **Trigo** or other menus to switch to the desired category (the selected category in the menu bar is highlighted), then rotate the knob to choose the desired waveform (the selected waveform is highlighted). Select Accept or press the knob to recall the corresponding waveform.

**Table Built-in Waveforms**

<b>Item</b>	<b>Waveform</b>	<b>Explanations</b>
Common	StairUp	Stair-up waveform
	StairDn	Stair-down waveform
	StairUD	Stair-up and down waveform
	Trapezia	Trapezia waveform
	Ppulse	Positive pulse
	Npulse	Negative pulse
	UpRamp	UpRamp waveform
	DnRamp	DnRamp waveform
	SineTra	Sine-Tra waveform
	SineVer	Sine-Ver waveform
Math	ExpFall	ExpFall function
	ExpRise	ExpRise function
	LogFall	LogFall function
	LogRise	LogRise function
	Sqrt	Sqrt function
	Root3	Root3 function
	X^2	X2 function
	X^3	X3 function
	Airy	Airy function
	Besselj	Bessel I function
	Bessely	Bessel II function
	Dirichlet	Dirichlet function
	Erf	Error function
	Erfc	Complementary error function
	ErfcInv	Inverted complementary error function
	ErfInv	Inverted error function
	Laguerre	4-times Laguerre polynomial
	Legend	5-times Legend polynomial
	Versiera	Versiera
	Sinc	Sinc function
	Gaussian	Gaussian function
	Dlorentz	Dlorentz function
	Haversine	Haversine function
	Lorentz	Lorentz function
	Gauspuls	Gauspuls signal
	Gmonopuls	Gmonopuls signal
	Tripuls	Tripuls signal
	Weibull	Weibull distribution
	LogNormal	LogNormal Gaussian distribution
	Laplace	Laplace distribution
	Maxwell	Maxwell distribution
Rayleigh	Rayleigh distribution	
Cauchy	Cauchy distribution	

Engine	Cardiac	Cardiac signal
	Quake	Analog quake waveform
	Chirp	Chirp signal
	TwoTone	TwoTone signal
	SNR	SNR signal
	AmpALT	Gain oscillation curve
	AttALT	Attenuation oscillation curve
	RoundHalf	RoundHalf Waveform
	RoundsPM	RoundsPM Waveform
	BlaseiWave	Time-velocity curve of explosive oscillation
	DampedOsc	Time-displacement curve of damped oscillation
	SwingOsc	Kinetic energy – time curve of swing oscillation
	Discharge	Discharge curve of NI-MH battery
	Pahcur	Current waveform of DC brushless motor
	Combin	Combination function
	SCR	SCR firing profile
	TV	TV signal
	Voice	Voice signal
	Surge	Surge signal
	Radar	Analog radar signal
	Ripple	Ripple wave of battery
	Gamma	Gamma signal
	StepResp	Step-response signal
	BandLimited	Bandwidth-limited signal
	CPulse	C-Pulse
	CWPulse	CW pulse
GateVibr	Gate self-oscillation signal	
LFMPulse	Linear FM pulse	
MCNoise	Mechanical construction noise	
Window	Hamming	Hamming window
	Hanning	Hanning window
	Kaiser	Kaiser window
	Blackman	Blackman window
	GaussiWin	GaussiWin window
	Triangle	Triangle window (Fejer window)
	BlackmanH	BlackmanH window
	Bartlett-Hann	Bartlett-Hann window
	Bartlett	Bartlett window
	BarthannWin	Modified Bartlett-Hann window
	BohmanWin	BohmanWin window
	ChebWin	ChebWin window
	FlattopWin	Flat top weighted window
	ParzenWin	ParzenWin window
	TaylorWin	TaylorWin window
	TukeyWin	TukeyWin (tapered cosine) window

Trigo	Tan	Tangent
	Cot	Cotangent
	Sec	Secant
	Csc	Cosecant
	Asin	Arc sine
	Acos	Arc cosine
	Atan	Arc tangent
	ACot	Arc cotangent
	Cosh	Hyperbolic cosine
	CosInt	Integral cosine
	Coth	Hyperbolic cotangent
	Csch	Hyperbolic cosecant
	SecH	Hyperbolic secant
	SinH	Hyperbolic sine
	SinInt	Integral sine
	TanH	Hyperbolic tangent
	ACosh	Arc hyperbolic cosine
	ASecH	Arc hyperbolic secant
	ASinH	Arc hyperbolic sine
	ATanH	Arc hyperbolic tangent
ACsch	Arc hyperbolic cosecant	
ACoth	Arc hyperbolic cotangent	

Square	SquareDuty01	Square waveform with 1% duty
	SquareDuty02	Square waveform with 2% duty
	SquareDuty04	Square waveform with 4% duty
	SquareDuty06	Square waveform with 6% duty
	SquareDuty08	Square waveform with 8% duty
	SquareDuty10	Square waveform with 10% duty
	SquareDuty12	Square waveform with 12% duty
	SquareDuty14	Square waveform with 14% duty
	SquareDuty16	Square waveform with 16% duty
	SquareDuty18	Square waveform with 18% duty
	SquareDuty20	Square waveform with 20% duty
	SquareDuty22	Square waveform with 22% duty
	SquareDuty24	Square waveform with 24% duty
	SquareDuty26	Square waveform with 26% duty
	SquareDuty28	Square waveform with 28% duty
	SquareDuty30	Square waveform with 30% duty
	SquareDuty32	Square waveform with 32% duty
	SquareDuty34	Square waveform with 34% duty
	SquareDuty36	Square waveform with 36% duty
	SquareDuty38	Square waveform with 38% duty
	SquareDuty40	Square waveform with 40% duty
	SquareDuty42	Square waveform with 42% duty
	SquareDuty44	Square waveform with 44% duty
	SquareDuty46	Square waveform with 46% duty
	SquareDuty48	Square waveform with 48% duty
	SquareDuty50	Square waveform with 50% duty
	SquareDuty52	Square waveform with 52% duty
	SquareDuty54	Square waveform with 54% duty
	SquareDuty56	Square waveform with 56% duty
	SquareDuty58	Square waveform with 58% duty
SquareDuty60	Square waveform with 60% duty	
SquareDuty62	Square waveform with 62% duty	
SquareDuty64	Square waveform with 64% duty	
SquareDuty66	Square waveform with 66% duty	
SquareDuty68	Square waveform with 68% duty	

Square	SquareDuty70	Square waveform with 70% duty
	SquareDuty72	Square waveform with 72% duty
	SquareDuty74	Square waveform with 74% duty
	SquareDuty76	Square waveform with 76% duty
	SquareDuty78	Square waveform with 78% duty
	SquareDuty80	Square waveform with 80% duty
	SquareDuty82	Square waveform with 82% duty
	SquareDuty84	Square waveform with 84% duty
	SquareDuty86	Square waveform with 86% duty
	SquareDuty88	Square waveform with 88% duty
	SquareDuty90	Square waveform with 90% duty
	SquareDuty92	Square waveform with 92% duty
	SquareDuty94	Square waveform with 94% duty
	SquareDuty96	Square waveform with 96% duty
	SquareDuty98	Square waveform with 98% duty
SquareDuty99	Square waveform with 99% duty	
Medical	EOG	Electro-Oculogram
	EEG	Electroencephalogram
	EMG	Electromyogram
	Pulseilogram	Pulseilogram
	ResSpeed	Speed curve of the respiration
	ECG1	Electrocardiogram 1
	ECG2	Electrocardiogram 2
	ECG3	Electrocardiogram 3
	ECG4	Electrocardiogram 4
	ECG5	Electrocardiogram 5
	ECG6	Electrocardiogram 6
	ECG7	Electrocardiogram 7
	ECG8	Electrocardiogram 8
	ECG9	Electrocardiogram 9
	ECG10	Electrocardiogram 10
	ECG11	Electrocardiogram 11
	ECG12	Electrocardiogram 12
	ECG13	Electrocardiogram 13
	ECG14	Electrocardiogram 14
	ECG15	Electrocardiogram 15
	LFPulse	Waveform of the low frequency pulse electrotherapy
Tens1	Waveform 1 of the nerve stimulation electrotherapy	
Tens2	Waveform 2 of the nerve stimulation electrotherapy	
Tens3	Waveform 3 of the nerve stimulation electrotherapy	
Mod	AM	Sectional sine AM signal
	FM	Sectional sine FM signal
	PFM	Sectional pulse FM signal
	PM	Sectional sine PM signal I
	PWM	Sectional PWM signal
Filter	Butterworth	Butterworth filter
	Chebyshev1	Chebyshev1 filter
	Chebyshev2	Chebyshev2 filter



Demo	demo1_375pts	TureArb waveform 1 (375 pts)
	demo1_16kpts	TureArb waveform 1 (16384 pts)
	demo2_3kpts	TureArb waveform 2 (3000 pts)
	demo2_16kpts	TureArb waveform 2 (16384 pts)

1. To select the **Stored Waveform**

Choose **[Waveforms]** → **[Page 1/2]** → **[Arb]** → **[Arb Type]** → **[Stored Waveforms]** to enter the following interface, as shown in Figure 38.

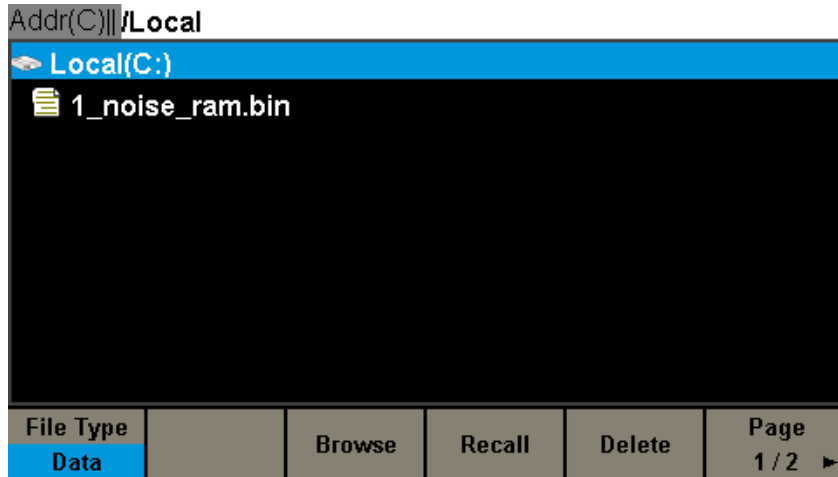

Figure 38: Stored Waveform Display Interface

Rotate the knob to choose the desired waveform. Then select Recall or press the knob to recall the corresponding waveform.

### 5.8. TO SET HARMONIC FUNCTION

The **GX 1030** can be used as a harmonic generator to output harmonics with specified order, amplitude and phase. According to the Fourier transform, a periodic time domain waveform is the superposition of a series of sine waveforms as shown in the equation below:

$$f(t) = A_1 \sin(2\pi f_1 t + \varphi_1) + A_2 \sin(2\pi f_2 t + \varphi_2) + A_3 \sin(2\pi f_3 t + \varphi_3) + \dots$$

Generally, the component with f1 frequency is called fundamental waveform, f1 is fundamental waveform frequency, A1 is fundamental waveform amplitude, and φ1 is fundamental waveform phase. The frequencies of the other components (called harmonics) are all integral multiples of the fundamental waveform. Components whose frequencies are odd multiples of the fundamental waveform frequency are called odd harmonics and components whose frequencies are even multiples of the fundamental waveform frequency are called even harmonics.

Press **[Waveforms]** → **[Sine]** → **[Harmonic]** and choose **On**, then press **[Harmonic Parameter]** to enter the following interface.

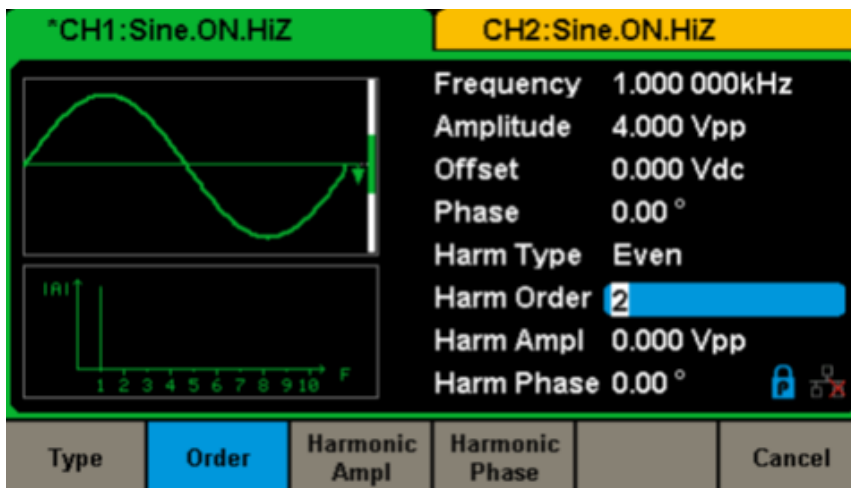

Figure 39: Harmonic Interface

Function menu	Explanations
Type	Set the harmonic type to Even, Odd, All.
Order	Set the order of the harmonic.
Harmonic Ampl	Set the amplitude of the harmonic.
Harmonic Phase	Set the phase of the harmonic.
Cancel	Return to the sine parameters menu.

### Menu Explanations of Harmonic

#### To Select the Harmonic Type

The **GX 1030** can output odd harmonics, even harmonics and user-defined orders of harmonics. After entering the harmonic setting menu, press Type to select the desired harmonic type.

1. Press [**Even**], the instrument will output fundamental waveform and even harmonics.
2. Press [**Odd**], the instrument will output fundamental waveform and odd harmonics.
3. Press [**All**], the instrument will output fundamental waveform and all the user-defined orders of harmonics.

#### To Set the Harmonic Order

After entering the harmonic setting menu, press Order, use the numeric keyboard or knob to input the desired value.

- The range is limited by the maximum output frequency of the instrument and current fundamental waveform frequency.
- Range: 2 to maximum output frequency of the instrument ÷ current fundamental waveform frequency
- The maximum is 16.

#### To Set the Harmonic Amplitude

After entering the harmonic setting menu, press [**Harmonic Ampl**] to set the harmonic amplitude of each order.

1. Press [**Order**] to select the sequence number of the harmonic to be set.
2. Press [**Harmonic Ampl**] to set the amplitude of the harmonic selected. Use the arrow keys and knob to change the value. Or use the numeric keyboard to input the amplitude value and the select the desired unit from the pop-up menu. The units available are Vpp, mVpp and dBc.

#### To select the Harmonic Phase

After entering the harmonic setting menu, press [**Harmonic Phase**] to set the harmonic phase of each order.

1. Press [**Order**] to select the sequence number of the harmonic to be set.
2. Press [**Harmonic Phase**] to set the phase of the harmonic selected. Use the arrow keys and knob to change the value. Or use the numeric keyboard to input the phase value and then select the unit.

## 5.9. TO SET MODULATION FUNCTION

Use the Mod key to generate modulated waveforms.

The **GX 1030** can generate AM, FM, ASK, FSK, PSK, PM, PWM and DSB-AM modulated waveforms. Modulating parameters vary with the types of the modulation. In AM, users can set the source (internal/external), depth, modulating frequency, modulating waveform and carrier. In DSB-AM, users can set the source (internal/external), modulating frequency, modulating waveform and carrier.

In FM, users can set the source (internal/external), modulating frequency, frequency deviation, modulating waveform and carrier. In PM, users can set the source (internal/external), phase deviation, modulating frequency, modulating waveform and carrier. In ASK, users can set the source (internal/external), key frequency and carrier. In FSK, users can set the source (internal/external), key frequency, hop frequency and carrier. In PSK, users can set the source (internal/external), key frequency, polarity and carrier. In PWM, users can set the source (internal/external), modulating frequency, width/duty cycle deviation, modulating waveform and carrier (Pulse type only).

We will introduce how to set these parameters in details according to the modulation types.

### 5.9.1. AM

The modulated waveform consists of two parts: the carrier and the modulating waveform. In AM, the amplitude of the carrier varies with the instantaneous voltage of the modulating waveform.

Press **[Mod]** → **[Type]** → **[AM]**, the parameters of AM modulation are shown in Figure 40.

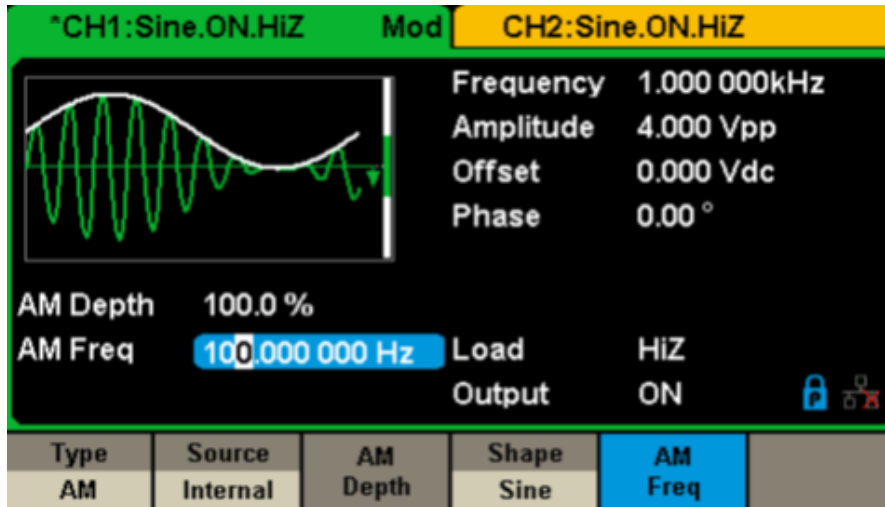

Figure 40: Setting Interface of AM Modulation

Function Menu	Settings	Explanations
Type	AM	Amplitude modulation
Source	Internal	The source is internal
	External	The source is external. Use the [Aux In/Out] connector at the rear panel.
AM Depth		Set the modulation depth.
Shape	Sine	Choose the modulating waveform.
	Square	
	Triangle	
	UpRamp	
	DnRamp	
	Noise	
	Arb	
AM Freq		Set the modulating waveform frequency. Frequency range: 1 mHz ~ 20 kHz (internal source only).

#### To Select Modulation Source

The GX 1030 can accept modulating signal from an internal or external modulation source. Press **[Mod]** → **[AM]** → **[Source]** to select **Internal** or **External** modulation source. The default is Internal.

#### 1. Internal Source

When internal AM modulation source is selected, press Shape to select Sine, Square, Triangle, UpRamp, DnRamp, Noise or Arb as modulating waveform.

- Square: 50 % duty cycle
- Triangle: 50 % symmetry
- UpRamp: 100 % symmetry
- DnRamp: 0 % symmetry
- Arb: the arbitrary waveform selected of the current channel.

**Note:** Noise can be used as modulating waveform but cannot be used as the carrier.

#### 2. External Source

When **external AM** modulation source is selected, the generator accepts external modulating signal from the [Aux In/Out] connector at the rear panel. At this time, the amplitude of the modulated waveform is controlled by the signal level applied to the connector. For example, if the modulation depth is set to 100 %, the output amplitude will be the maximum when the modulating signal is +6 V and the minimum when the modulating signal is -6 V.

**Key Points:**

The **GX 1030** can use one channel as a modulating source for the other channel. The following example takes the output signal of CH2 as the modulating waveform.

1. Connect the CH2 output terminal to [Aux In/Out] connector on the rear panel using a dual BNC cable
2. Select CH1 and press Mod to select the desired modulation type as well as set the corresponding parameters, and then select external modulation source.
3. Select CH2 and select the desired modulating waveform and set the corresponding parameters.
4. Press Output to enable the output of CH1.

**To Set Modulation Depth**

Modulation depth expressed as a percentage indicates the amplitude variation degree. AM modulation depth varies from 1 % to 120 %. Press **AM Depth** to set the parameter.

- In the 0 % modulation, the output amplitude is half of the carrier's amplitude.
- In the 120 % modulation, the output amplitude is the same as the carrier's amplitude.
- For an external source, the depth of AM is controlled by the voltage level on the connector connected to the [Aux In/Out]. ± 6 V correspond to 100 % depth.
- When external modulation source is selected, this menu is hidden.

**To Set Modulation Frequency**

When internal modulation source is selected, press **AM Freq** to highlight the parameter, then use the numeric keyboard or arrow keys and knob to input the desired value.

- The modulation frequency ranges from 1 mHz to 20 kHz.
- When external modulation source is selected, this menu is hidden.

**5.9.2. DSB-AM**

DSB-AM is an abbreviation for Double-Sideband Suppressed Carrier –Amplitude Modulation. Press [type Mod] → [DSB-AM]. The parameters of DSB-AM modulation are shown in Figure 41.

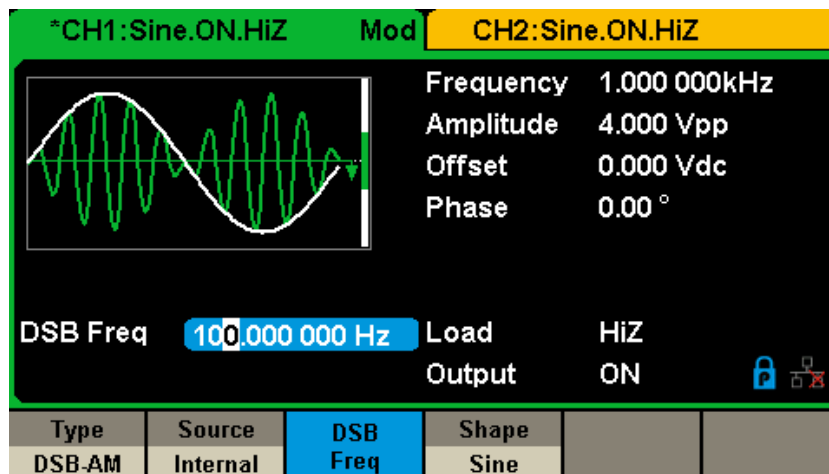

**Figure 41: Setting Interface of DSB-AM Modulation**

Function Menu	Settings	Explanations
Type	DSB-AM	DSB Amplitude modulation
Source	Internal	The source is internal
	External	The source is external. Use the [Aux In/Out] connector at the rear panel.
DSB Freq		Set the modulating waveform frequency. Frequency range: 1 mHz ~ 20 kHz (internal source only).
Shape	Sine	Choose the modulating waveform.
	Square	
	Triangle	
	UpRamp	
	DnRamp	
	Noise	
	Arb	

**Table Menu Explanations of DSB-AM Parameters**

**Note:** The methods of setting the parameters of DSB-AM are similar to AM

### 5.9.3. FM

The modulated waveform consists of two parts: the carrier and the modulating waveform. In FM, the frequency of the carrier varies with the instantaneous voltage of the modulating waveform.

Press **[Mod]** → **[Type]** → **[FM]**, the parameters of FM modulation are shown in Figure 42.

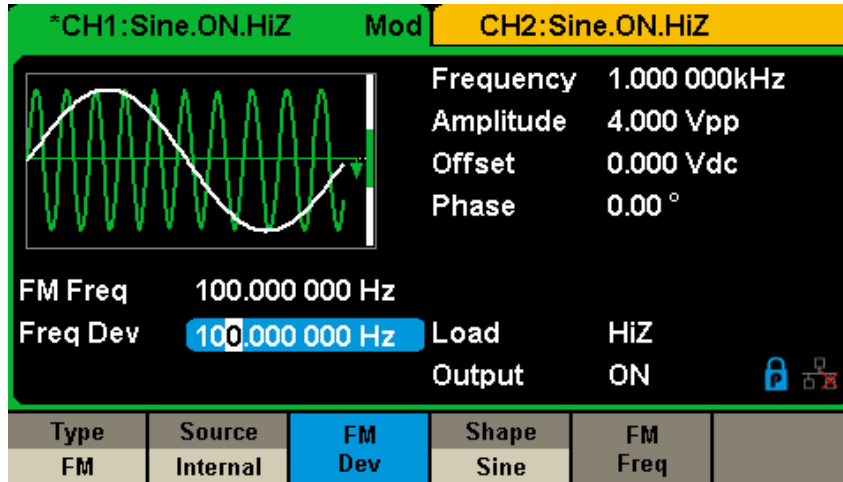

Figure 42: Setting Interface of FM Modulation

Function Menu	Settings	Explanations
Type	FM	Frequency modulation
Source	Internal	The source is internal
	External	The source is external. Use the [Aux In/Out] connector at the rear panel.
Freq Dev		Set the frequency deviation
Shape	Sine	Choose the modulating waveform.
	Square	
	Triangle	
	UpRamp	
	DnRamp	
	Noise	
Arb		
FM Freq		Set the modulating waveform frequency. Frequency range: 1 mHz ~ 20 kHz (internal source).

#### To Set Frequency Deviation

Press **FM Dev** to highlight the parameter, and then use the numeric keyboard or arrow keys and knob to input the desired value.

- The deviation should be equal to or less than the carrier frequency.
- The sum of the deviation and the carrier frequency should be equal to or less than maximum frequency of the selected carrier waveform.

**Note:** The methods of setting other parameters of FM are similar to AM.

### 5.9.4. PM

The modulated waveform consists of two parts: the carrier and the modulating waveform. In PM, the phase of the carrier varies with the instantaneous voltage level of the modulating waveform.

Press **[Mod]** → **[Type]** → **[PM]**, the parameters of PM modulation are shown in Figure 43.

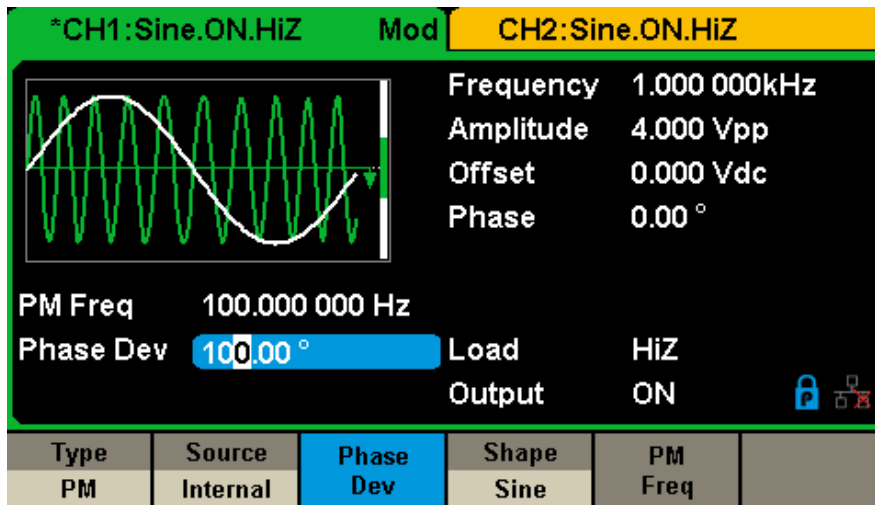

Figure 43: Setting Interface of PM Modulation

Function Menu	Settings	Explanations
Type	PM	Phase modulation
Source	Internal	The source is internal
	External	The source is external. Use the [Aux In/Out] connector at the rear panel.
Phase Dev		Phase deviation ranges from 0° ~ 360°.
Shape	Sine	Choose the modulating waveform.
	Square	
	Triangle	
	UpRamp	
	DnRamp	
	Noise	
	Arb	
PM Freq		Set the modulating waveform frequency. Frequency range: 1 mHz ~ 20 kHz.

Table Menu Explanations of the PM Parameters

#### To Set Phase Deviation

Press **[Phase Dev]** to highlight the parameter, and then use the numeric keyboard or arrow keys and knob to input the desired value.

- Use the numeric keyboard or arrow keys and knob to input the desired value.
- The range of phase deviation is from 0° to 360° and the default value is 100°.

**Note:** The methods of setting other parameters of PM are similar to AM.

### 5.9.5. FSK

The FSK is "Frequency Shift Keying", the output frequency of which switches between two preset frequencies (carrier frequency and the hop frequency or sometimes known as mark frequency (1) and space frequency (0)).

Press [Mod] → [Type] → [FSK], the parameters of FSK modulation are shown in Figure 44.

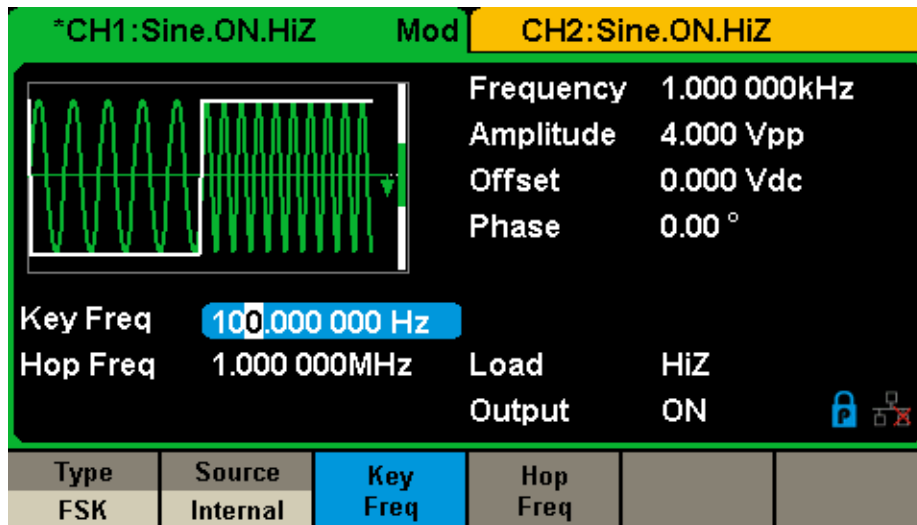

Figure 44: Setting Interface of FSK Modulation

Function Menu	Settings	Explanations
Type	FSK	Frequency shift keying modulation
Source	Internal	The source is internal
	External	The source is external. Use the [Aux In/Out] connector at the rear panel.
Key Freq		Set the frequency at which the output frequency shifts between the carrier frequency and the hop frequency (internal modulation only): 1 mHz ~ 50 kHz.
Hop Freq		Set the hop frequency.

Table Menu Explanations of the FSK Parameters

#### To Set Key Frequency

When internal modulation source is selected, press [Key Freq] to set the rate at which the output frequency shifts between carrier frequency and hop frequency

- Use the numeric keyboard or arrow keys and knob to input the desired value.
- The key frequency ranges from 1 mHz to 50 kHz.
- When external modulation source is selected, this menu is hidden.

#### To Set Hop Frequency

The range of the hop frequency depends on the carrier frequency currently selected. Press [Hop Freq] to highlight the parameter, and then use the numeric keyboard or arrow keys and knob to input the desired value.

- Sine: 1 μHz ~ 30 MHz
- Square: 1 μHz ~ 25 MHz
- Ramp: 1 μHz ~ 500 kHz
- Arb: 1 μHz ~ 6 MHz

**Note:** The methods of setting other parameters of FSK are similar to AM. In addition, the external modulating signal of FSK must be Square which complies with the CMOS level specification.

### 5.9.6. ASK

When using ASK (Amplitude Shift Keying), the carrier frequency and key frequency will need to be set. The key frequency is the shift rate of modulated waveform amplitude.

Press [Mod] → [Type] → [ASK], the parameters of ASK modulation are shown in Figure 45.

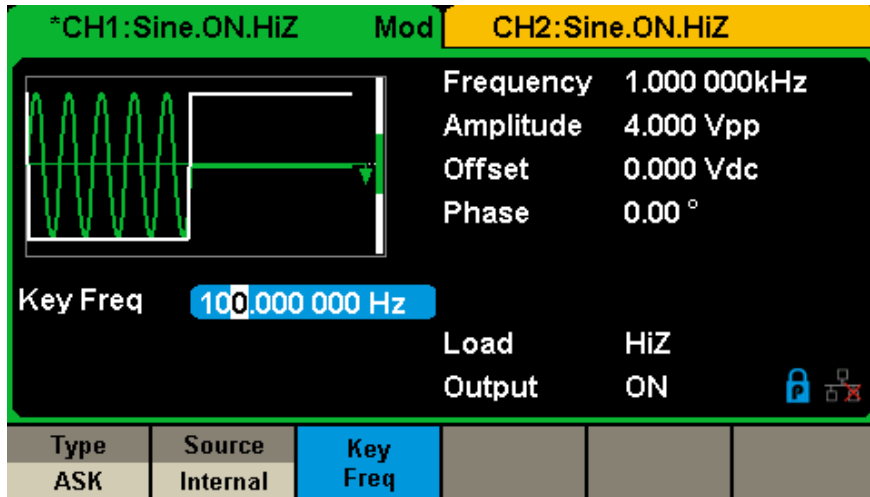

Figure 45: Setting Interface of ASK Modulation

Function Menu	Settings	Explanations
Type	ASK	Amplitude shift keying modulation
Source	Internal	The source is internal
	External	The source is external. Use the [Aux In/Out] connector at the rear panel.
Key Freq		Set the frequency at which the output amplitude shifts between the carrier amplitude and zero (internal modulation only): 1 mHz ~ 50 kHz.

Table Menu Explanations of the ASK Parameters

**Note:** The methods for setting the parameters of ASK are similar to AM. In addition, the external modulating signal of ASK must be Square which complies with the CMOS level specification.

### 5.9.7. PSK

When using PSK (**Phase Shift Keying**), configure the generator to its output phase between two preset phase values (carrier phase and modulating phase). The default modulating phase is 180°.

Press [Mod] → [Type] → [PSK], the parameters of PSK modulation are shown in Figure 46.

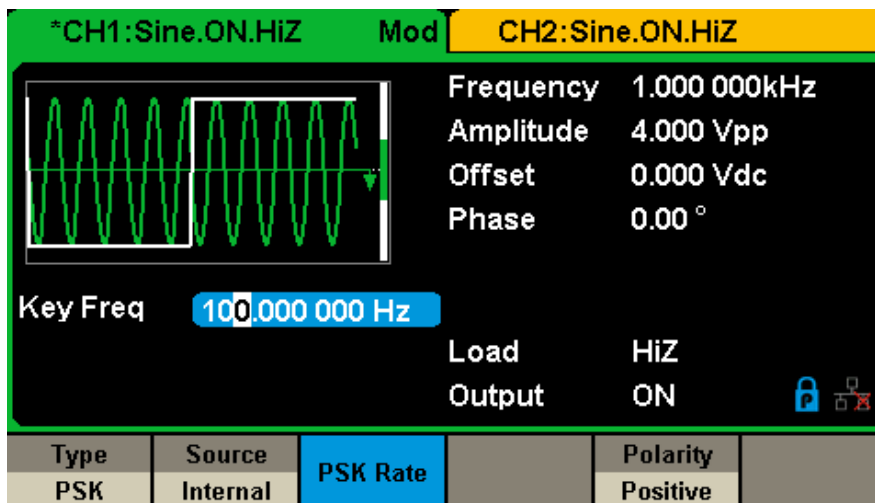

Figure 46: Setting Interface of PSK Modulation



Function Menu	Settings	Explanations
Type	PSK	Phase shift keying modulation
Source	Internal	The source is internal
	External	The source is external. Use the [Aux In/Out] connector at the rear panel.
Key Freq/PSK Rate		Set the frequency at which the output phase shifts between the carrier phase and 180° (internal modulation only): 1 mHz ~ 20 kHz.
Polarity	Positive	Set the modulating polarity.
	Negative	

**Table Menu Explanations of the PSK Parameters**

**Note:** The methods of setting the parameters of PSK are similar to AM. In addition, the external modulating signal of PSK must be Square which complies with the CMOS level specification.

### 5.9.8. PWM

In PWM (**Pulse Width Modulation**), the pulse width of the pulse varies with the instantaneous voltage of the modulating waveform. **The carrier can only be pulse.**

Press [Waveforms] → [Pulse] → [Mod] the parameters of PWM modulation are shown in Figure 47.

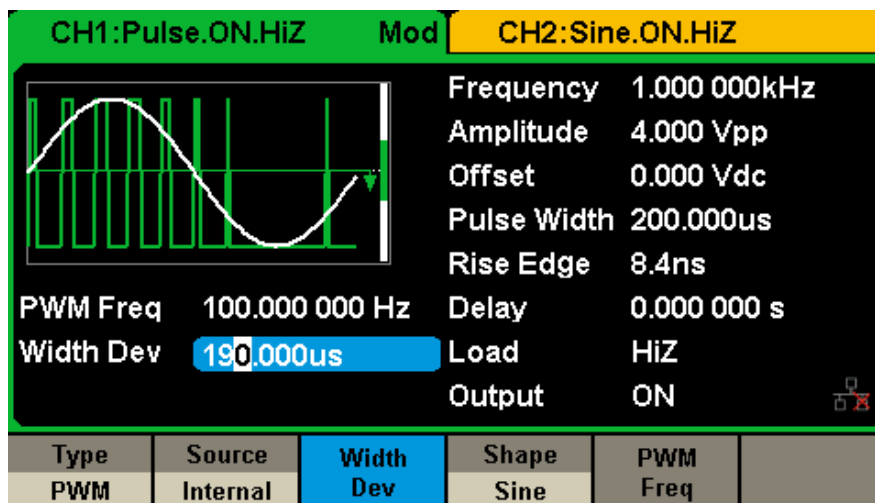

**Figure 47: Setting Interface of PWM Modulation**

Function Menu	Settings	Explanations
Type	PWM	Pulse width modulation. The carrier is pulse.
Source	Internal	The source is internal
	External	The source is external. Use the [Aux In/Out] connector at the rear panel.
Width Dev		Set the width deviation
	Sine	Choose the modulating waveform.
	Square	
	Triangle	
	UpRamp	
	DnRamp	
	Noise	
	Arb	
PWM Freq		Set the modulating waveform frequency. Frequency range: 1 mHz ~ 20 kHz (internal source only).

**Table Menu Explanations of the PWM Parameters**

**To Set Pulse Width/Duty Deviation**

Width Deviation represents the variation of the modulated waveform pulse width relative to the original pulse width. Press **[Width Dev]** to highlight the parameter, and use the numeric keyboard or arrow keys and knob to input the desired value, as shown in the Figure 48.

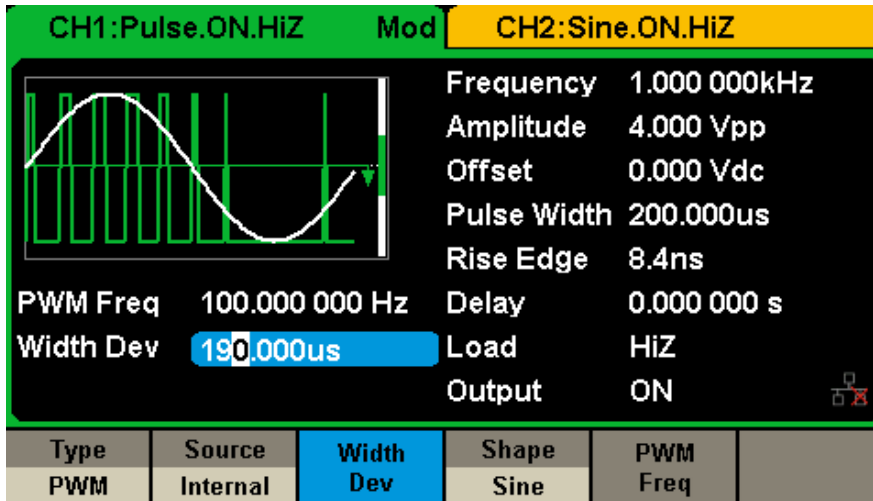

Figure 48: Width Deviation Setting Interface

- The width deviation cannot exceed the current pulse width.
- The width deviation is limited by the minimum pulse width and current edge time setting.

**5.10. TO SET SWEEP FUNCTION**

In the sweep mode, the generator steps from the start frequency to the stop frequency in the sweep time specified by the user. The waveforms that support sweep include sine, square, ramp and arbitrary.

Press **[Sweep]** key to enter the following menu. Set the waveform parameters by using the operation menu.

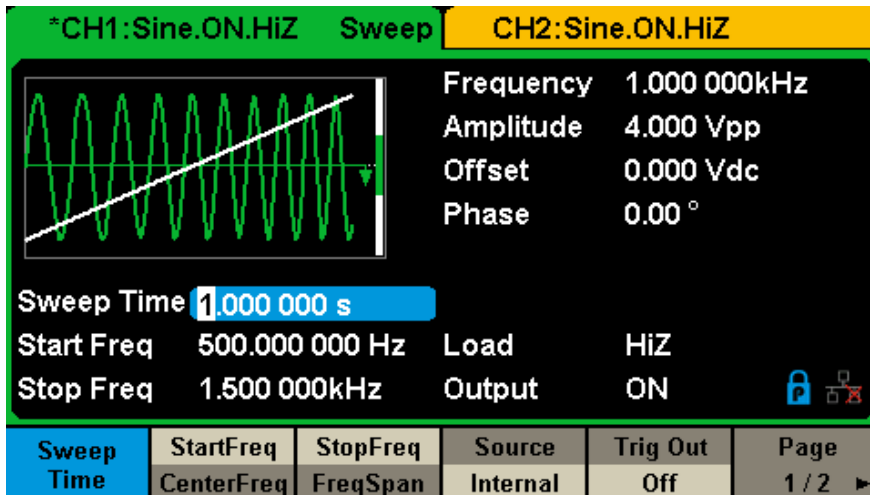

Figure 49: Setting Interface of Sweep (Page 1/2)

Function Menu	Settings	Explanations
Sweep time		Set the time span of the sweep in which the frequency changes from the start frequency to stop frequency.
Start Freq Mid Freq		Set the start frequency of the sweep. Set the center frequency of the sweep.
Stop Freq Freq Span		Set the stop frequency of the sweep. Set the frequency span of the sweep.
Source	Internal	Choose internal source as a trigger.
	External	Choose external source as a trigger. Use the [Aux In/Out] connector at the rear panel.
	Manual	Trigger a sweep manually.
Trig Out	Off	Disable trigger out.
	On	Enable trigger out.
Page 1/2		Enter the next page.

Table Menu Explanations of Sweep (Page 1/2)

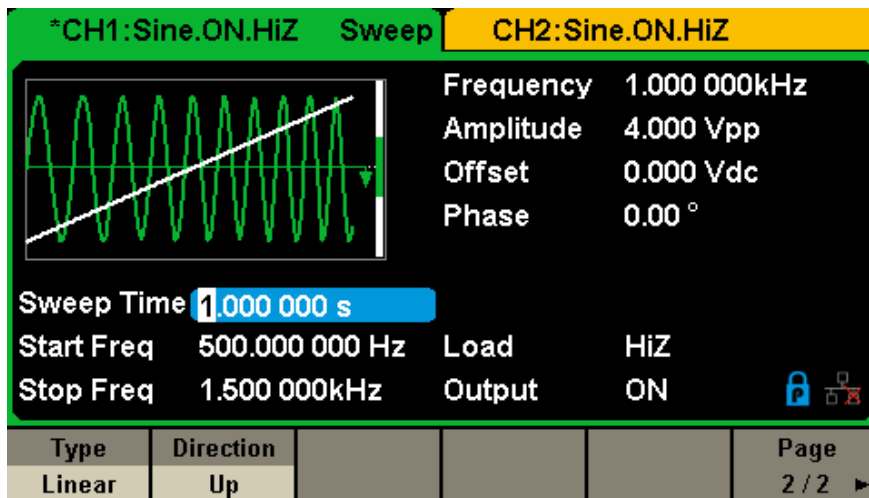

Figure 50: Setting Interface of Sweep (Page 2/2)

Function Menu	Settings	Explanations
Sweep time type	Linear	Set the sweep with linear profile.
	Log	Set the sweep with logarithmic profile.
Direction	Up	Sweep upward.
	Down	Sweep downward.
Page 2/2		Return to the previous page.

Table Menu Explanations of Sweep (Page 2/2)

### Sweep Frequency

Use start freq and stop freq or center freq and freq span to set the range of the frequency sweep. Press the key again to switch between the two sweep range modes.

### Start Frequency and Stop Frequency

Start Frequency and Stop Frequency are the lower and upper limits of the frequency for sweep. Start Frequency ≤ Stop Frequency.

- Choose [Direction] → [Up], the generator will sweep from Start frequency to Stop frequency.
- Choose [Direction] → [Down], the generator will sweep from Stop frequency to Start frequency.

### Center Frequency and Frequency Span

Center Frequency = (|Start Frequency + Stop Frequency|)/2Frequency

Span = Stop Frequency - Start Frequency

### Sweep type

GX 1030 provides Linear and Log sweep profiles and the default is Linear.

### Linear sweep

In linear sweep, the output frequency of the instrument varies linearly in the way of a number of Hertz per second. Choose **[Sweep]** → **[Page 1/2]** → **[Type]** → **[Linear]**, there is a straight line displayed on the waveform on the screen, indicating that the output frequency varies linearly.

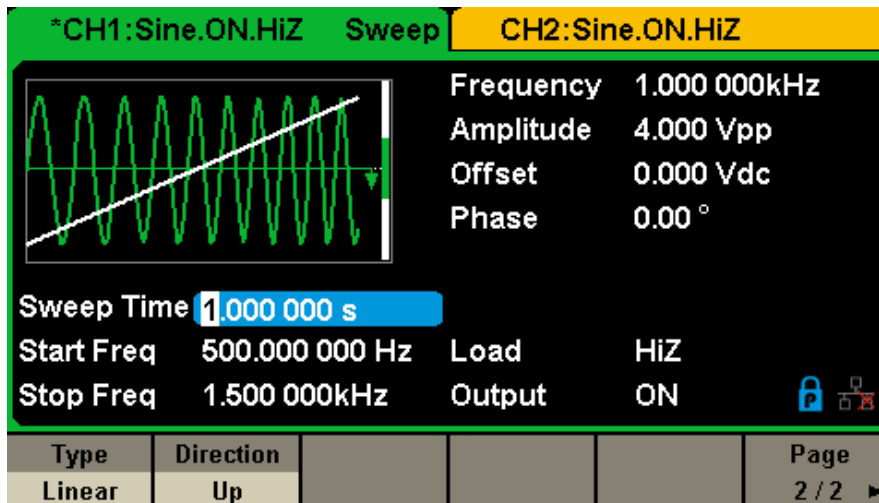

Figure 51: Linear Sweep Interface

### Log Sweep

In log sweep, the output frequency of the instrument varies in a logarithmic fashion, that is, the output frequency changes in the way of decade per second. Choose **[Sweep]** → **[Page 1/2]** → **[Type]** → **[Log]**, there is an exponential function curve displayed on the waveform on the screen, indicating that the output frequency changes in a logarithmic mode.

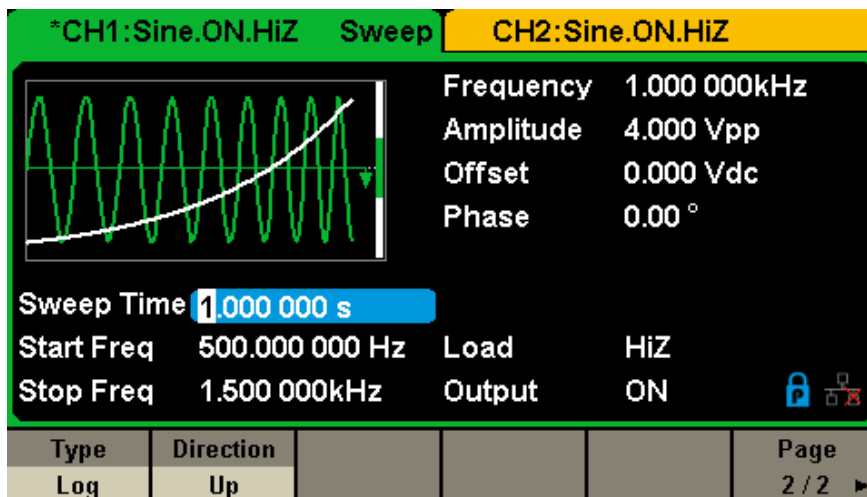

Figure 52: Log Sweep Interface

### Sweep Trigger Source

The sweep trigger source can be internal, external or manual. The generator will generate a sweep output when a trigger signal is received and then wait for the next trigger source.

#### 1. Internal Trigger

Choose **[Source]** → **[Internal]**, the generator outputs continuous sweep waveform when internal trigger is selected. The default is internal. Choose **[Trig Out]** → **[On]**, the [Aux In/Out] connector at the rear panel will output the trigger signal.

#### 2. External Trigger

Choose **[Source]** → **[External]**, the generator accepts the trigger signal inputted from the [Aux In/Out] connector at the rear panel when external trigger is selected. A sweep will be generated once the connector receives a CMOS pulse with specified polarity. To set the CMOS pulse polarity, choose **[Edge]** to select Up or Down.

#### 3. Manual Trigger

Choose **[Source]** → **[Manual]**, a sweep will be generated from the corresponding channel when the Trigger softkey is pressed when manual trigger is selected. Choose **[Trig Out]** → **[On]**, the [Aux In/Out] connector at the rear panel will output the trigger signal.

## 5.11. TO SET BURST FUNCTION

The Burst function can generate versatile waveforms in this mode. Burst times can last a specific number of waveform cycles (N-Cycle mode), or when an external gated signals (Gated mode) is applied. Any waveform (except DC) may be used as the carrier, but noise can only be used in Gated mode.

### Burst Type

**GX 1030** provides three burst types including N-Cycle, Infinite and Gated. The default is N-Cycle.

Burst Type	Trigger Source	Carrier
N-Cycle	Internal/External/Manual	Sine, Square, Ramp, Pulse, Arbitrary
Infinite	External/Manual	Sine, Square, Ramp, Pulse, Arbitrary
Gated	Internal/External	Sine, Square, Ramp, Pulse, Noise, Arbitrary

**Table Relations among burst type, trigger source and carrier**

### N-Cycle

In N-Cycle mode, the generator will output waveform with a specified number of cycles after receiving the trigger signal. Waveforms that support N-Cycle burst include sine, square, ramp, pulse and arbitrary.

Press **[Burst]** → **[NCycle]** → **[Cycles]**, and use the numeric keyboard or arrow keys and knob to input the desired cycles. Set the waveform parameters using the operation menu, as shown in Figure 53 and Figure 54.

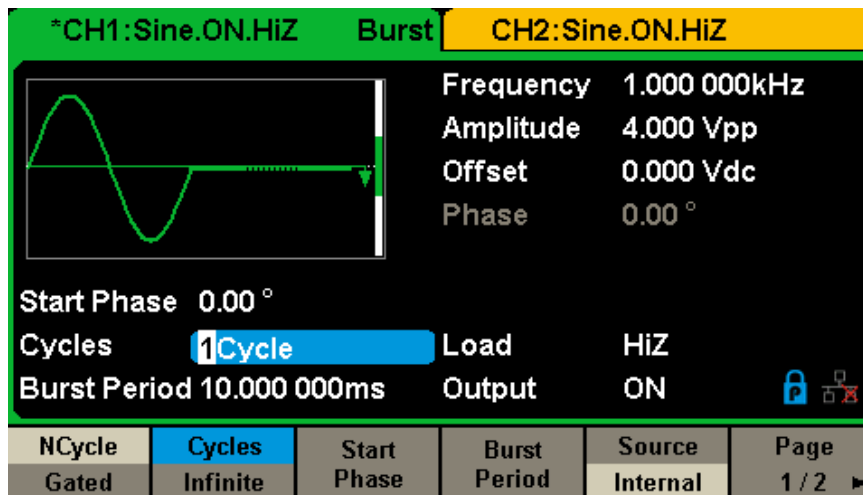

**Figure 53: N-Cycle Burst Interface (Page 1/2)**

Function Menu	Settings	Explanations
N-Cycle		Use the N-Cycle mode.
Cycles		Set the number of the bursts in N-Cycle.
Infinite		Set the number of the bursts in N-Cycle to be infinite.
Start Phase		Set the start frequency of the burst.
Burst Period		Set the burst period.
Source	Internal	Choose internal source as a trigger.
	External	Choose external source as a trigger. Use the [Aux In/Out] connector at the rear panel.
	Manual	Trigger a burst manually.
Page 1/2		Enter the next page.

**Table Menu Explanations of the N-Cycle Burst (Page 1/2)**

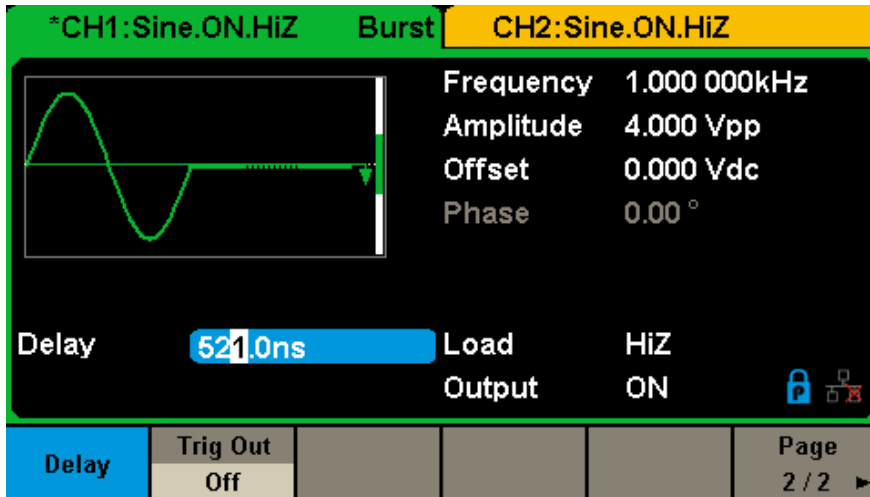

Figure 54: N-Cycle Burst Interface (Page 2/2)

Function Menu	Settings	Explanations
Trig Delay		Set the delay time before the burst starts.
Trig Out	Off	Disable trigger out.
	On	Enable trigger out.
Page 2/2		Return to the previous page.

Table Menu Explanations of the N-Cycle Burst (Page 2/2)

### Infinite

In infinite mode, the cycle number of the waveform is set as an infinite value. The generator outputs a continuous waveform after receiving the trigger signal. Waveforms that support infinite mode include sine, square, ramp, pulse and arbitrary.

Press **[Burst]** → **[NCycle]** → **[Infinite]**, and set the trigger source to external or manual. The screen will display an infinite cycle burst, as shown in Figure 55.

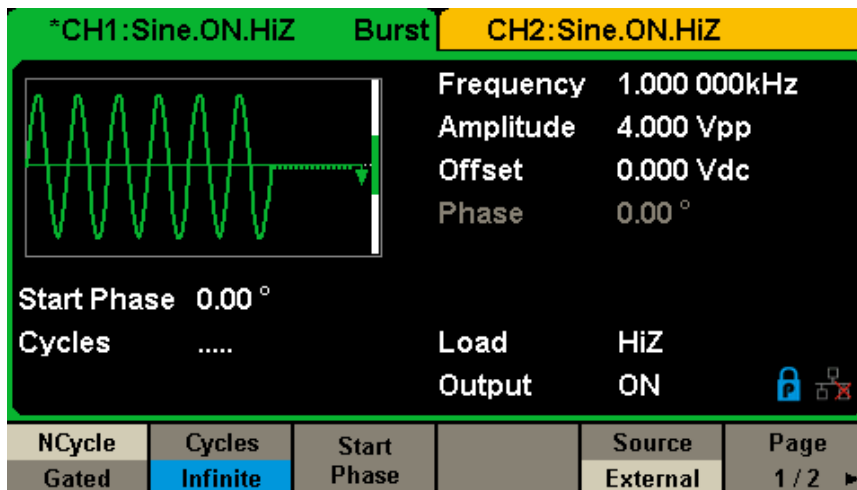

Figure 55: Infinite Burst Interface

### Gated

In gated mode, the generator controls the waveform output according to the gate signal level. When the gated signal is true the generator outputs a continuous waveform. When the gated signal is false the generator first completes the output of the current period and then stops. Waveforms that support gated burst include sine, square, ramp, pulse, noise and arbitrary.

Press **[Burst]** → **[Gated]**, to enter the following interface.

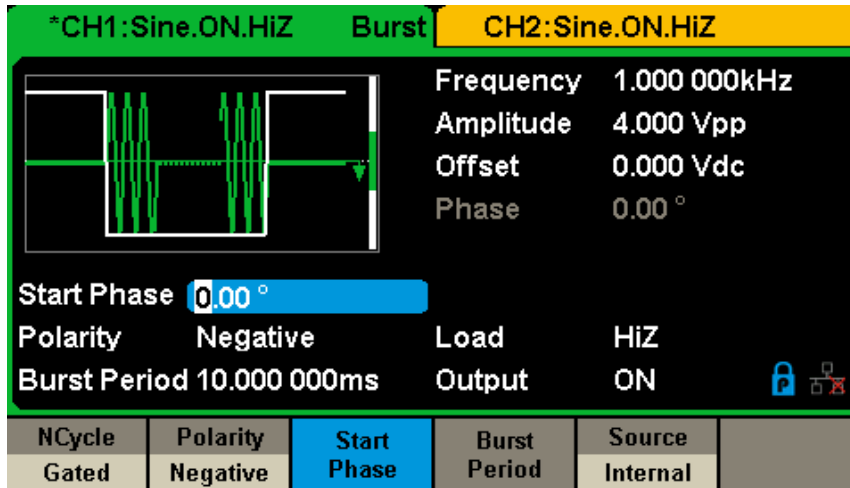

Figure 56: Gated Burst Interface

Function Menu	Settings	Explanations
Gated		Use the gated mode.
Polarity	Positive	Set the polarity for the gated signal.
	Negative	
Start Phase		Set the start phase of the burst.
Burst Period		Set the burst period. (source internal only)
Source	Internal	Choose internal source as a trigger.
	External	Choose external source as a trigger. Use the [Aux In/Out] connector at the rear panel.

Table Menu Explanations of the Gated Burst

### Start Phase

Define the start point in a waveform. The phase varies from 0° to 360°, and the default setting is 0°. For an Arbitrary Waveform, 0° is the first waveform point.

### Burst Period

Burst Period is only available when the trigger source is internal. It is defined as the time from the start of a burst to the start of the next one. Choose **[Burst Period]** and use the numeric keyboard or arrow keys and knob to input the desired value.

- Burst Period ≥ 0.99 μs + carrier period x burst number
- If the current burst period set is too short, the generator will increase this value automatically to allow outputting the specified number of cycles.

### Cycles/Infinite

Set the number of waveform cycle in an N-Cycle (1 to 50,000 or Infinite).

If Infinite is chosen, then a continuous waveform will be generated once a trigger occurs.

### Delay

Set the time delay between the trigger input and the start of the N-Cycle burst.

### Burst Trigger Source

The burst trigger source can be internal, external or manual. The generator will generate a burst output when a trigger signal is received and then wait for the next trigger source.

#### 1. Internal Trigger

Choose **[Source]** → **[Internal]**, the generator outputs continuous burst waveform when internal trigger is selected. Choose **[Trig Out]** as Up or Down the [Aux In/Out] connector at the rear panel will output a trigger signal with specified edge.

#### 2. External Trigger

Choose **[Source]** → **[External]**, the generator accepts the trigger signal inputted from the [Aux In/Out] connector at the rear panel when external trigger is selected. A burst will be generated once the connector gets a CMOS pulse with specified polarity. To set the CMOS pulse polarity, choose **[Edge]** to select Up or Down.

#### 3. Manual Trigger

Choose **[Source]** → **[Manual]**, a burst will be generated from the corresponding channel when the **Trigger** softkey is pressed when manual trigger is selected.

## 6. TO STORE AND RECALL

**GX 1030** can store the current instrument state and user-defined arbitrary waveform data in internal or external memory and recall them when needed.

Press [**Store/Recall**] to enter the following interface.

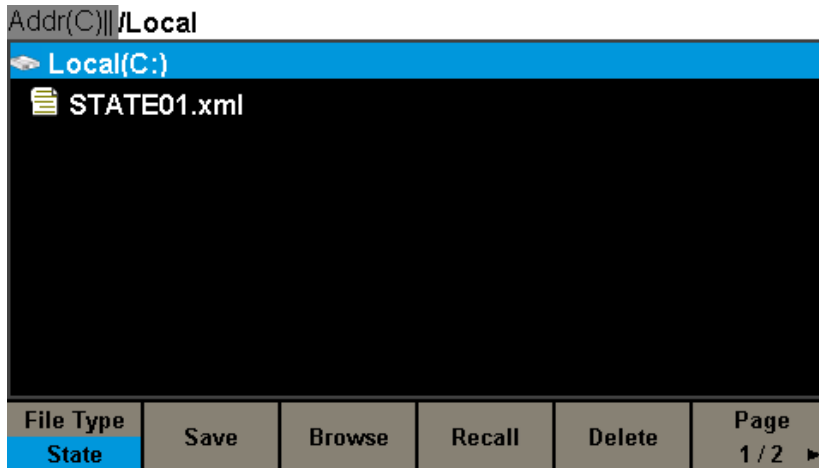

**Figure 57: Store/Recall Interface (Page 1/2)**

Function Menu	Settings	Explanations
File Type	State	The setting of the generator.
	Data	Arbitrary waveform file.
Browse		View the current directory.
Save		Save the waveform to the specified path.
Recall		Recall the waveform or setting information in the specific position of the memory.
Delete		Delete the selected file.
Page 1/2		Enter the next page.

**Table Menu Explanations of Save and Recall**

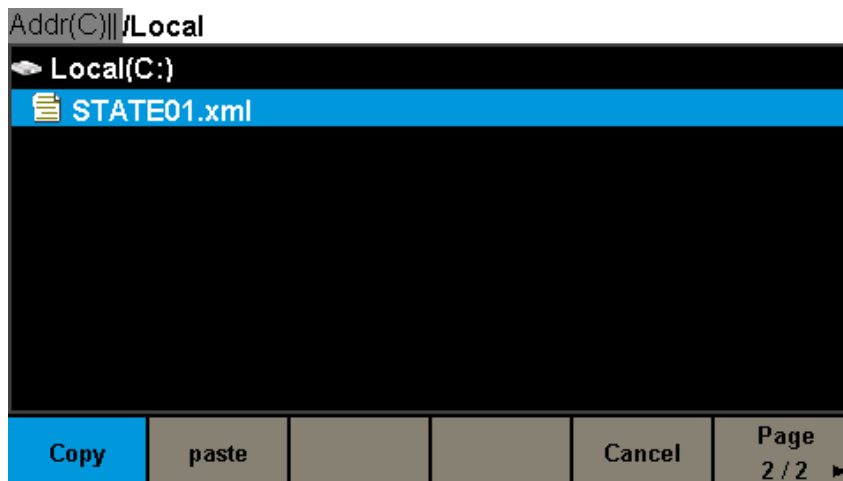

**Figure 58: Store/Recall Interface (Page 2/2)**

Function Menu	Settings	Explanations
Copy		Copy the selected file.
Paste		Paste the selected file.
Return		Exit the Store/Recall interface.
Page 2/2		Return to the previous page.

**Table Menu Explanations of Save and Recall**



## 6.1. STORAGE SYSTEM

The **GX 1030** provides an internal non-volatile memory (C Disk) and a USB Host interface for external memory.

### 1. Local (C:)

Users can store instrument states and arbitrary waveform files to C Disk.

### 2. USB Device (0:)

There is a USB Host interface located on the left side of the front panel which permits users to store/recall waveforms or update the firmware version by U-Disk. When the generator detects a USB storage device, the screen will show the drive letter USB Device (0:) and display a prompt message USB device connected, as shown in Figure 59. After removing the U-Disk, the screen will display a prompt message USB device removed. And USB Device (0:) in the storage menu will disappear.

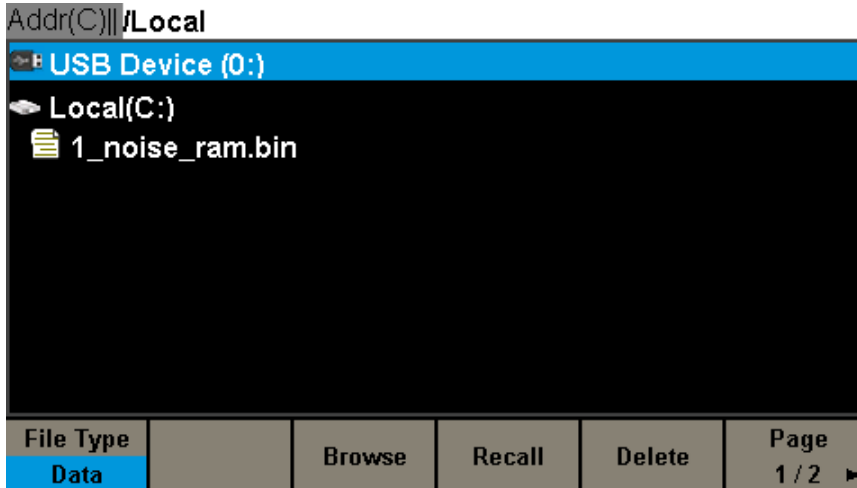

Figure 59: Storage System

**Note:** The **GX 1030** can only identify files of which filenames consist of English letters, number and underscore. If other characters are used, the name may be displayed in the store and recall interface abnormally.

### Browse

- Use the knob to shift between the directories to choose Local (C:) or USB Device (0:). Choose **[Browse]**, press the knob to open the current directory.
- Use the knob to switch between folder and files under the current directory. Choose **[Browse]**, press the knob to open the subdirectory. Choose **<up>**, then choose Brower or press the knob to return to the upper level directory.

## 6.2. FILE TYPE

Choose **[Store/Recall]** → **[File Type]** to select the desired file type. Available file types are State File and Data File.

### State File

Store the instrument state in internal or external memory in **—\*.xml** format. The state file stored includes waveform parameters and modulation, sweep, burst parameters of two channels and utility parameters.

### Data File

The **GX 1030** can recall the data files in **\*.csv** or **\*.dat** format from external memory and transfer them into **\*.bin** format then store them in the internal memory. When it is done, the generator will enter the arbitrary waveform interface automatically.

In addition, users can edit arbitrary waveforms with PC software **EasyWave** or **SX GENE**, download them to the internal memory through remote interface and store them (in **\*.bin** format) in the internal memory.

### 6.3. FILE OPERATION

#### To Save the Instrument State

Users can store the current instrument state in internal and external memories. The storage will save the selected function (including the basic waveform parameters, modulation parameters and other utility settings used.)

To save the instrument state, the procedures are given as follows:

**1. Choose the file type to store.**

Press **[Store/Recall]** → **[File Type]** → **[State]**, and choose state as the storage.

**2. Choose the location of the file.**

Choose a desired location by rotating the knob.

**3. Name the file.**

Press **[Save]**, to enter the following interface.

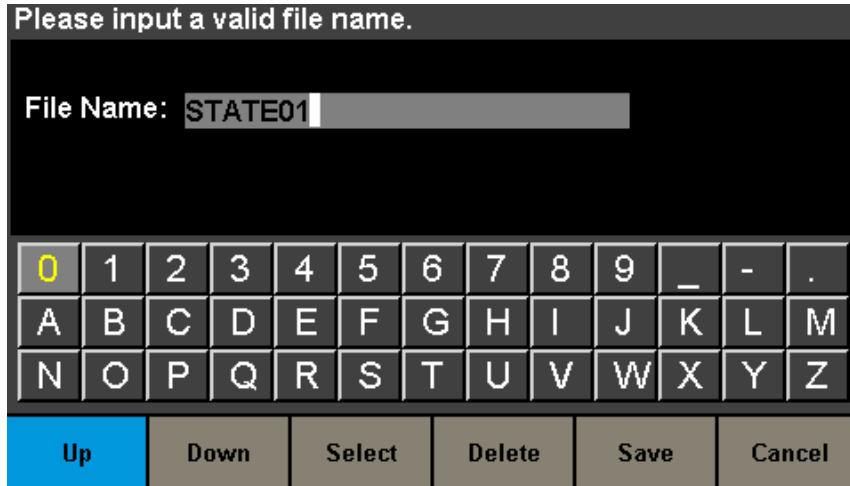

Figure 60: Filename Input Interface

Function Menu	Settings	Explanations
Up		Cursor upward to select.
Down		Cursor downward to select.
Select		Select the current character.
Delete		Delete the current character.
Save		Store the file with the current name.
Cancel		Return to the Store/Recall interface.

Table Menu Explanations of File Storage

**4. Select the character**

Users can select the desired character from the virtual soft keyboard by using the knob or **Up** and **Down** menus. Then choose **[Select]** to display the character selected in the filename area.

**Delete the character**

Use the left and right arrow keys to move the cursor in the file name. Then choose **[Delete]** to delete the corresponding character.

**5. Save the file**

After finishing inputting filename, press **[Save]**. The generator will save the file under the currently selected directory with the specified filename.

#### To Recall State File or Data File

To recall the instrument state or arbitrary waveform data, the procedures are as follows:

**1. Choose the file type**

Press **[Store/Recall]** → **[File type]**, and choose state or data as the storage type.

**2. Choose the file to be recalled**

Rotate the knob to select the file you want to recall.

### 3. Recall the file

Choose **[Recall]**, press the knob, the generator will recall the selected file and display corresponding prompt message when the file is read successfully.

### To Delete File

To delete the instrument state or arbitrary waveform data, the procedures are as follows:

#### 1. Choose the file

Rotate the knob to select the file you want to delete.

#### 2. Delete the file

Choose **[Delete]**, the generator will display prompt message "Delete the file" Then press **[Accept]**, the generator will delete the currently selected file.

### To Copy and Paste File

**GX 1030** supports the internal and external storage to copy files from each other. For example, copy an arbitrary wave file in the U-disk to the instrument, the procedure is as follows:

#### 1. Choose the file type

Press **[Store/Recall]** → **[File Type]**, and choose Data as the storage type.

#### 2. Choose the file to be copied

Rotate the knob to select USB Device (0:) and press the knob to open its directory. Then rotate the knob to select the file you want to copy and press **[Page 1/2]** → **[Copy]**.

#### Paste the file.

Rotate the knob to select Local (C:) and press the knob to open its directory. Then press **[Paste]**.

## 7. TO SET UTILITY FUNCTION

With the Utility function, the user can set the parameters of the generator such as Sync, Interface, System Setting, Self Test and Frequency Counter, etc.

Press **[Utility]** to enter the utility menu, as shown in Figure 61 and Figure 62.

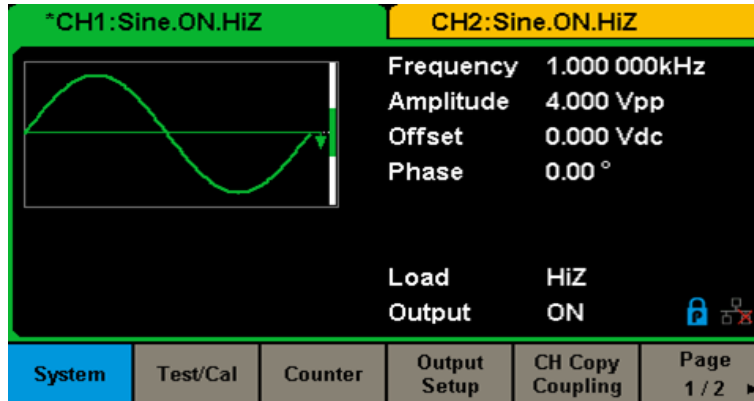

Figure 61: Utility Setup Interface (Page 1/2)

Function Menu	Settings	Explanations
System		Set the system configuration.
Test/Cal		Test and calibrate the instrument.
Counter		Frequency counter setting.
Output Setup		Set the output parameters of CH1 and CH2.
CH Copy Coupling		Set the track, channel coupling or channel copy function.
Page 1/2		Go to the next page.

Table Menu Explanations of Utility (Page 1/2)

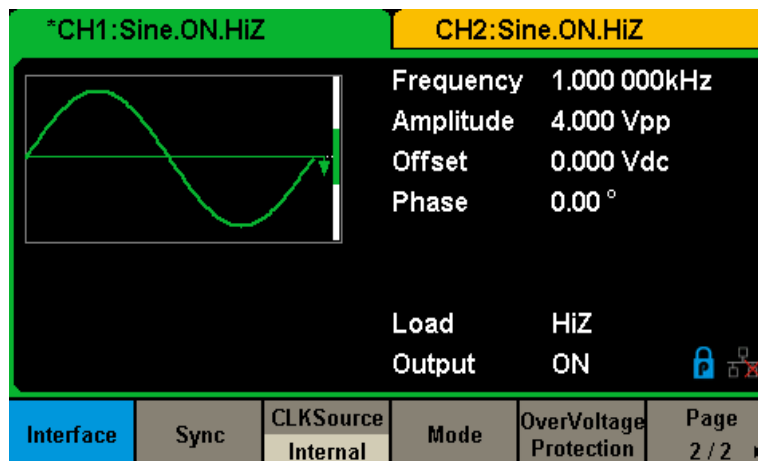

Figure 62: Utility Setup Interface (Page 2/2)

Function Menu	Settings	Explanations
Interface		Set the parameters of remote interfaces.
Sync		Set the sync output.
CLKSource	Internal	Choose the system clock source.
	External	
Phase Mode		Choose Phase-locked or independent mode.
OverVoltage Protection		Turn on/off the overvoltage protection function.
Page 2/2		Return to the previous page.

Table Menu Explanations of Utility (Page 2/2)

## 7.1. SYSTEM SETTINGS

Press [Utility] → [System], to enter the following interface.

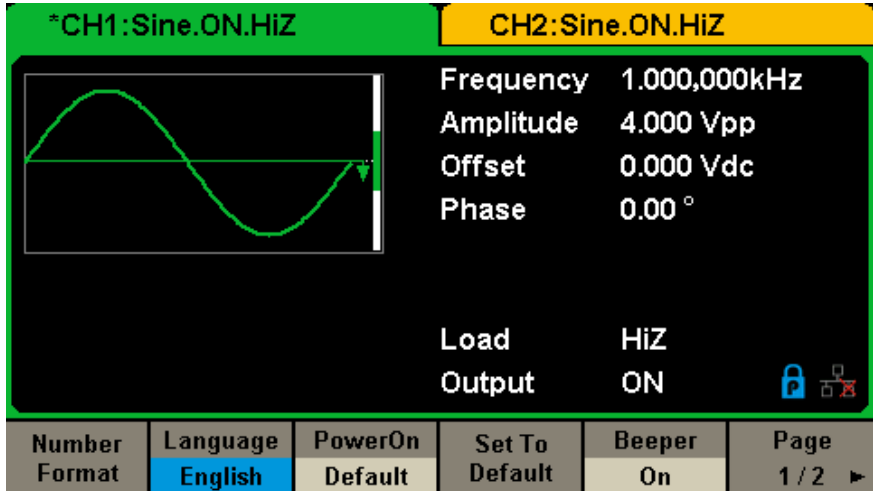

Figure 63: System Setup Interface (Page 1/2)

Function Menu	Settings	Explanations
Number format		Set the number format.
Language	English	Set the language.
	Chinese	
PowerOn	Default	All the settings return to default when power on.
	Last	All the settings return to the setting of the last power on.
	User	All the settings recall in .xml file
Set to Default		Set all the settings to default.
Beeper	On	Turn on the beeper.
	Off	Turn off the beeper.
Page 1/2		Enter the next page.

Table Menu Explanations of System Setup (Page 1/2)

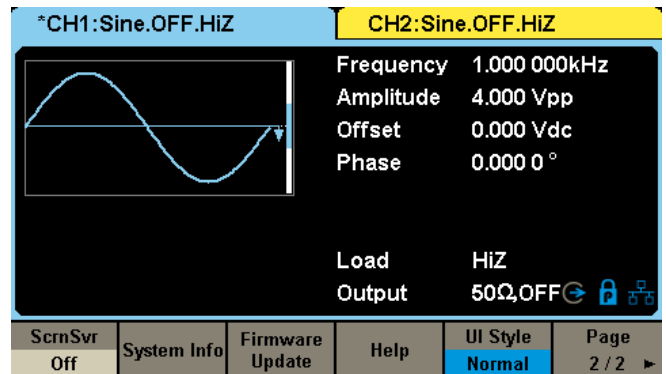
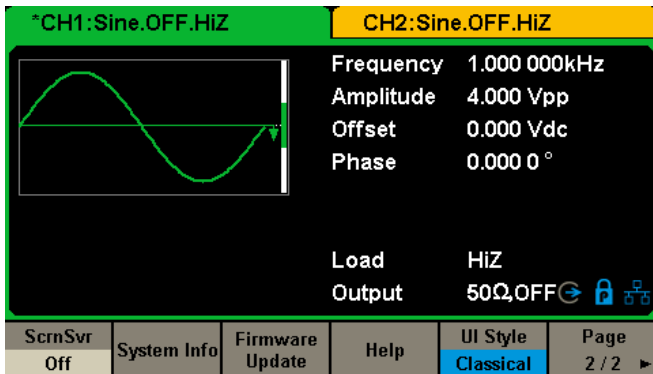

Figure 64a & 64b: System Setup Interface (Page 2/2)

Function Menu	Settings	Explanations
ScrnSvr	1 min	Enable or disable the screen saver.
	5 min	
	15 min	
	30 min	
	1 hour	
	2 hour	
	5 hour	
	Off	Disable the screen saver.
System Info		View the system information
Firmware Update		Update the firmware by the U-disk.
Help		View the Help information.
UI Style classical *		CH1: green CH2: orange
UI Style normal *		CH1: blue CH2: yellow
Page 2/2		Return to the previous page.

Table Menu Explanations of System Setup (Page 2/2)

**Note** \*: Please wait for a few seconds after UI style was changed, then reboot the device.

### 1. Number Format

Press [Utility] → [System] → [Number Format], to enter the following interface.

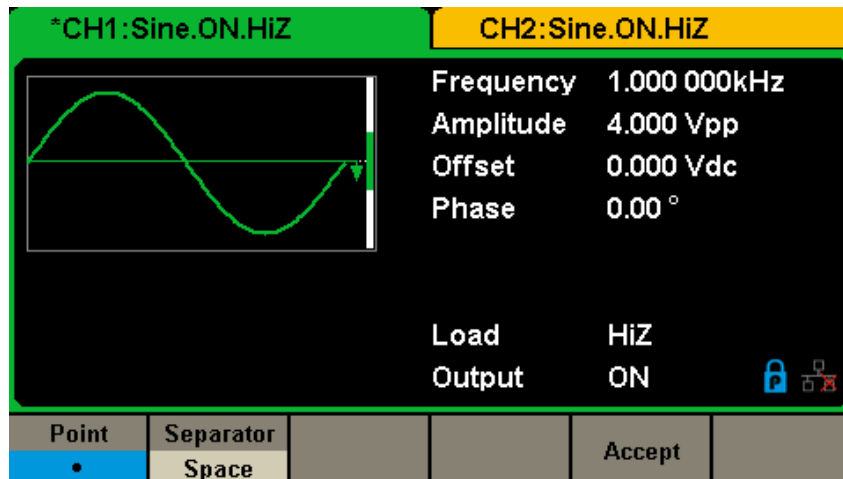

Figure 65: Set the Number Format

Function Menu	Settings	Explanations
Point	.	Use dot to represent decimal point.
	,	Use comma to represent decimal point.
Separator	On	Enable the Separator.
	Off	Turn off the Separator.
	Space	Use Space as the separator.
Accept		Save the current settings and return to the System menu.

Table Menu Explanations of Setting the Number Format

According to the different choices of the decimal point and the separator, the format can have various forms.

### 2. Language Setup

The generator offers two languages (English and Simplified Chinese). Press [Utility] → [System] → [Language], to select the desired language. This setting is stored in non-volatile memory and will not be influenced by the **Set To Default** operation.

English Interface

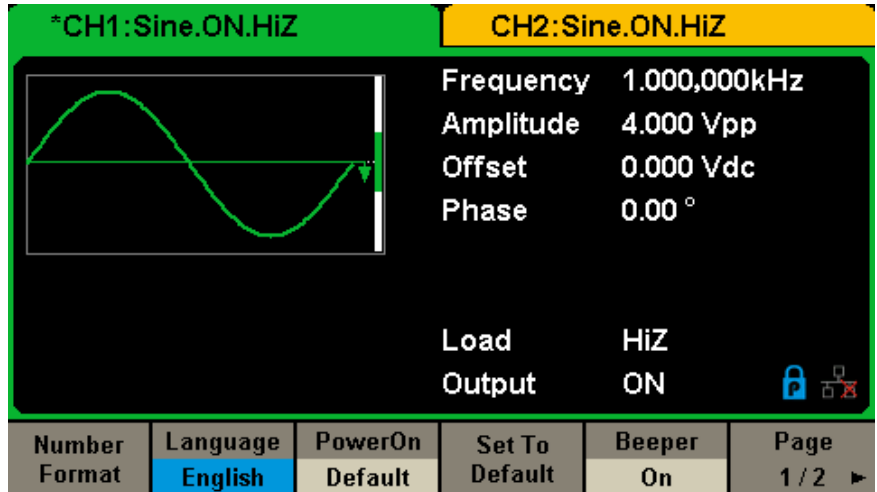

Figure 66: English Interface

3. Power On Setting

Choose the **GX 1030**'s setting when the generator is powered on. 3 choices are available: the default setting and the last settings set when the unit was last powered down. Once selected, the setting will be applied when the instrument is powered on. This setting is stored in non-volatile memory and will not be influenced by the **Set To Default** operation. Last: includes all system parameters and states, except channel output state.

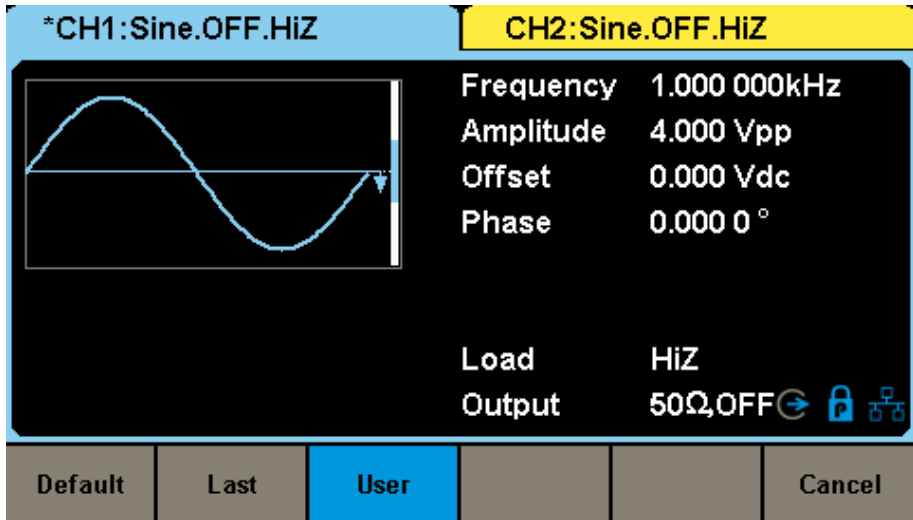

Figure 67: Power On Setting

- **Default:** denotes the factory defaults except certain parameters (such as Language).
- **Last:** set the unit with the last powered down
- **User:** select "type.xml file" file source on local memory

#### 4. Set to Default

Press **[Utility]** → **[System]** → **[Set To Default]**, to set the system to the default setting. The default settings of the system are as followed:

<b>Output</b>	<b>Default</b>
Function	Sine Wave
Frequency	1 kHz
Amplitude/Offset	4 Vpp/0 Vdc
Phase	0°
Load	High Z
<b>Modulation</b>	<b>Default</b>
Carrier	1 kHz Sine Wave
Modulating	100 Hz Sine Wave
AM Depth	100 %
FM Deviation	100 Hz
ASK Key Frequency	100 Hz
FSK Key Frequency	100 Hz
FSK Hop Frequency	1 MHz
PSK Key Frequency	100 Hz
PM Phase Deviation	100°
PWM Width Dev	190 μs
<b>Sweep</b>	<b>Default</b>
Start/Stop Frequency	500 Hz/1.5 kHz
Sweep Time	1 s
Trig Out	Off
Mode	Linear
Direction	↑
<b>Burst</b>	<b>Default</b>
Burst Period	10 ms
Start Phase	0°
Cycles	1 Cycle
Trig Out	Off
Delay	521 ns
<b>Trigger</b>	<b>Default</b>
Source	Internal

**Table Factory Default Setting**

#### 5. Beeper

Enable or disable the beeper. Press **[Off]** → **[Utility]** → **[System]** → **[Beeper]** to select **On** and the default is **On**.

#### 6. Screen Saver

Enable or disable screen saver. Press **[Utility]** → **[System]** → **[Page 1/2]** → **[ScrnSvr]** to select On or Off and the default is Off. Screen saver will be in if no action is taken within the time that you have selected. Press any key to resume.

#### 7. System Info

Select the **System Info** option of the utility menu to view the generator's system information, including startup times, software version, hardware version, model and serial number.



<b>Startup Times:</b>	<b>1</b>
<b>Software Version:</b>	<b>1.01.01.33R2T1</b>
<b>Hardware Version:</b>	<b>03-00-00-24-00</b>
<b>Product Type:</b>	<b>GX1030</b>
<b>Serial No:</b>	<b>SDG1XDCC6R1968</b>

**Please press any soft key to exit !**

**Figure 68: System Information Interface**

### **8. Update**

The software version and configuration file of the generator can be updated directly via U-disk. Follow the steps below:

1. Insert U-disk with firmware update file (\*.ADS) and configuration file (\*.CFG) to USB host interface on the front panel of the generator.
2. Press **[Utility]** → **[Page 1/2]** → **[Firmware Update]**. Or press **[Store/Recall]** directly.
3. Select the firmware file (\*.ADS) and choose **[Recall]** to update the system software.
4. After the updating is finished, the generator will restart automatically.
5. Press **[Utility]** → **[Page 1/2]** → **[Firmware Update]**. Or press **[Store/Recall]** directly.
6. Select the configuration file (\*.CFG) and choose **[Recall]** to update the configuration file.
7. After the updating is finished, the generator will restart automatically.

#### **Note:**

1. Don't cut off the power while the generator is being updated !
2. A configuration file (\*.CFG) may or may not be included with a given firmware update. If a CFG file is not included with a firmware update then it will not be required for that update.

### **9. Built-in Help System**

The **GX 1030** provides a built-in help system, by which users can view the help information at any time when operating the instrument. Press **[Utility]** → **[System]** → **[Page 1/2]** → **[Help]** to enter the following interface.

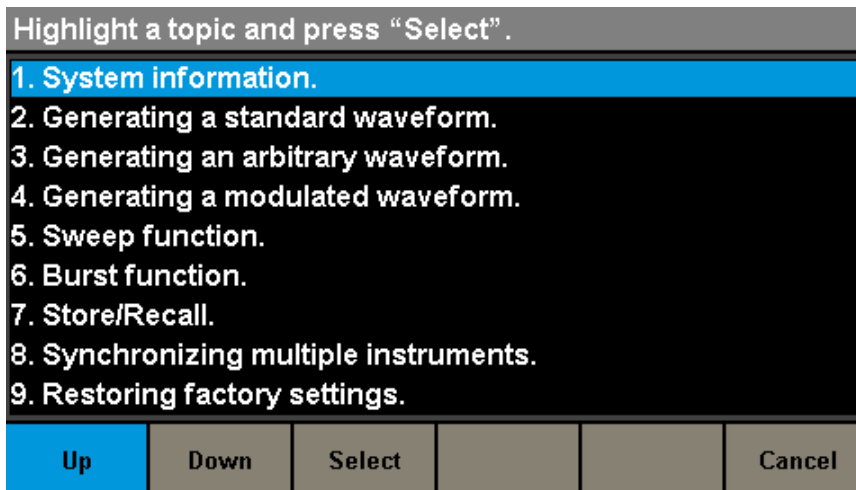

Figure 69: Built-in Help System

Function Menu	Settings	Explanations
UP		Cursor upward to select.
Down		Cursor downward to select.
Select		Read the currently selected help information.
Cancel		Exit the built-in help system.

There are 9 topics in the help list. You can use the knob and/or operation menus to select the help information that you want to read.

## 7.2. TEST/CAL

Choose [Utility] → [Test/Cal], to enter the following interface.

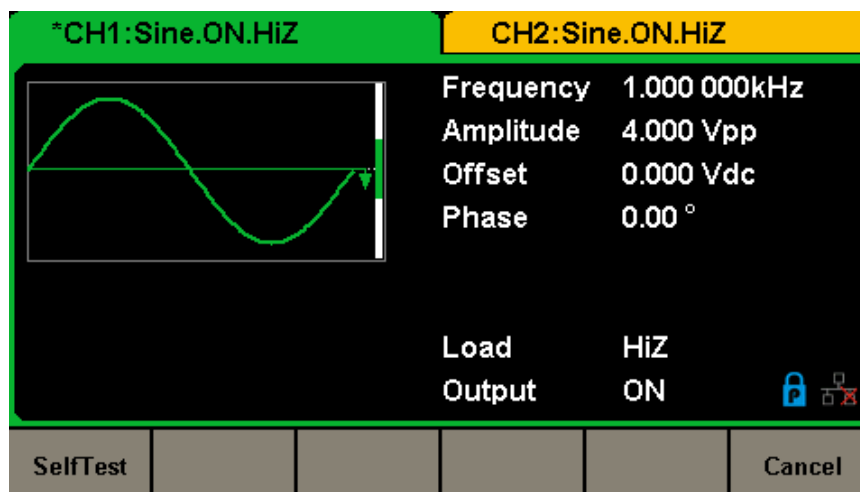

Figure 70: Test/Cal function Menu

Function Menu	Settings	Explanations
SelfTest		Perform a system self-test.
Cancel		Return to the Utility menu.

Table Menu Explanations of Test/Cal Setting

**Self Test**

Press [Utility] → [Test/Cal] → [SelfTest], to enter the following menu.

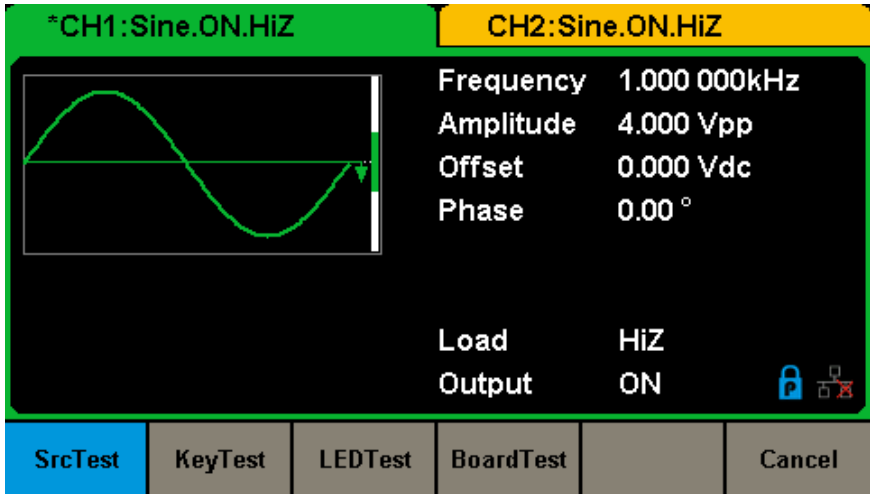

Figure 71: Self Test Interface

Function Menu	Settings	Explanations
ScrTest		Run screen test program.
KeyTest		Run keyboard test program.
LEDTest		Run key indicator lights test program.
BoardTest		Run hardware circuit self-test program.
Cancel		Return to the Test/Cal menu.

Table Menu Explanations of Self Test

**1. ScrTest**

Select [ScrTest] to enter the screen test interface. The prompt message Please press 7' key to continue, press 8' key to exit.' is displayed. Press the 7' key for test and observe if there is any serious color deviation, bad pixel or display error.

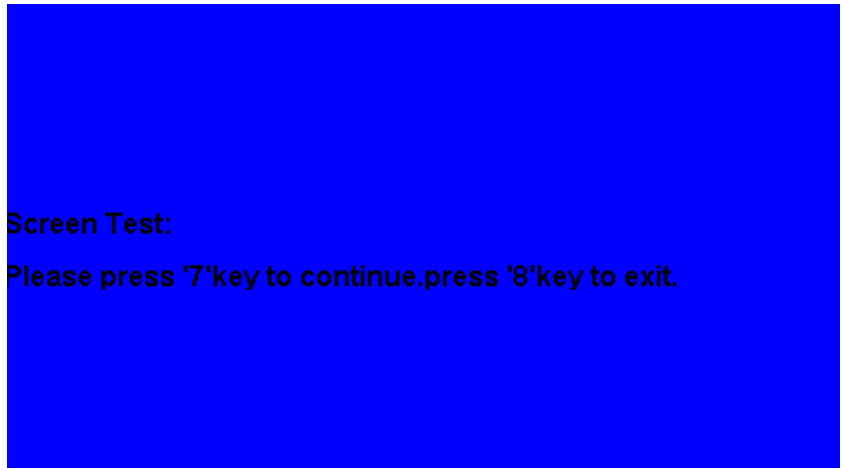

Figure 72: Screen Test Interface

### 2. Key Test

Select **KeyTest** to enter the keyboard test interface, the on-screen white rectangle shapes represent the front panel keys. The circle between two arrows represents the knob. Test all keys and knob and also verify that all the backlight keys illuminate correctly.

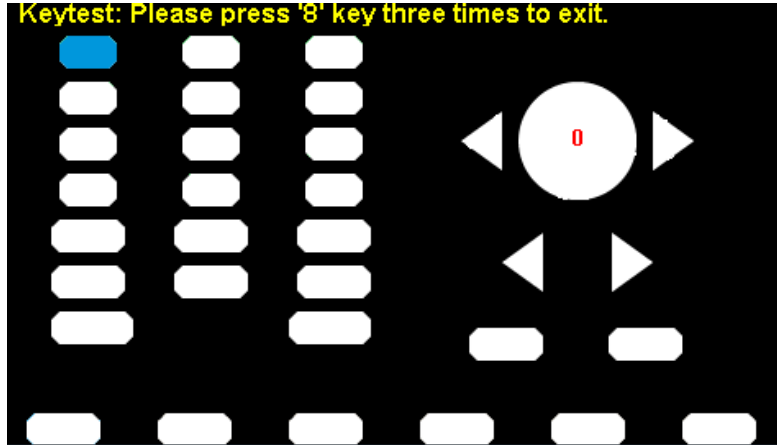

Figure 73: Key Test Interface

The corresponding area of tested keys or knob would display in blue color. The top of the screen displays Please press "8" key three times to exit. '

### 3. LED Test

Select **LEDTest** to enter the LED test interface, the on-screen white rectangle shapes represent the front panel keys. The prompt message Please press "7" Key to continue, press "8" Key to exit. ' is displayed. Press the "7" key continuously for testing and when a key is lighted, the corresponding area on the screen will display in blue color.

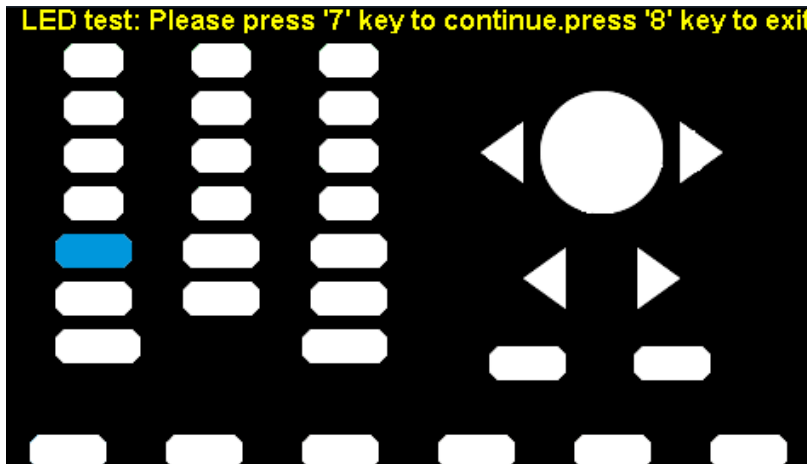

Figure 74: LED Test Interface

### 4. Board Test

Select **Board Test** to enter the following interface.

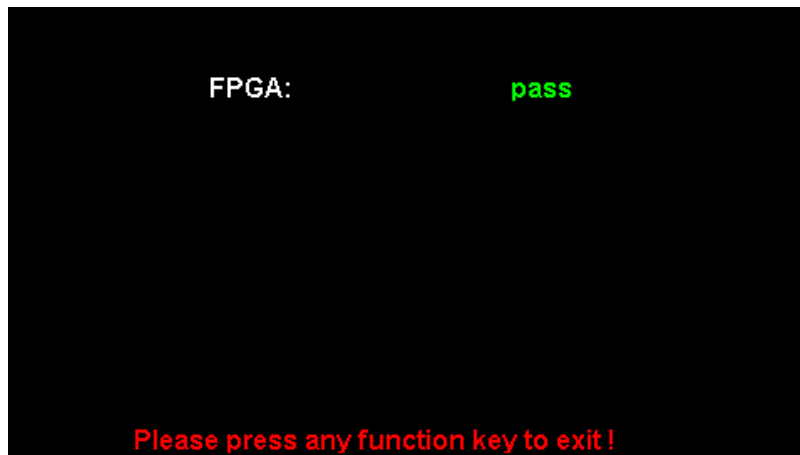

Figure 75: Board Test Interface

### 7.3. FREQUENCY COUNTER

The **GX 1030** provides a frequency counter which can measure frequencies between 100 MHz to 200 MHz. The dual channels can still output normally when the counter is enabled. Press following **[Utility]** → **[Counter]**, to enter the interface.

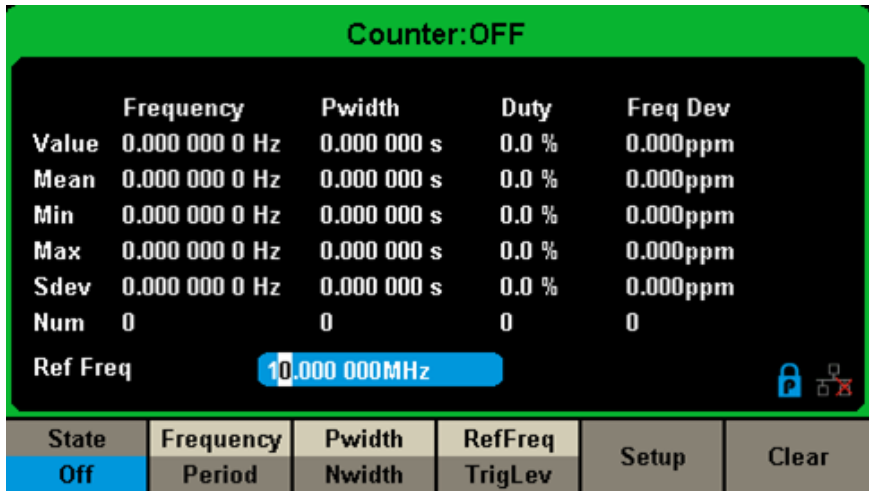

Figure 76: Frequency Counter Interface

Function Menu	Settings	Explanations
State	Off	Turn off the counter.
	On	Turn on the counter.
Frequency		Measured frequency.
Period		Measured period.
PWidth		Measured positive width.
NWidth		Measured negative width.
RefFreq		Set the reference frequency. System will calculate the deviation between the measured frequency and the reference frequency automatically.
TrigLev		Set the trigger level voltage.
Setup		Set the counter configuration.
Clear		Clear the statistical data.

Table Menu Explanations of Frequency Counter

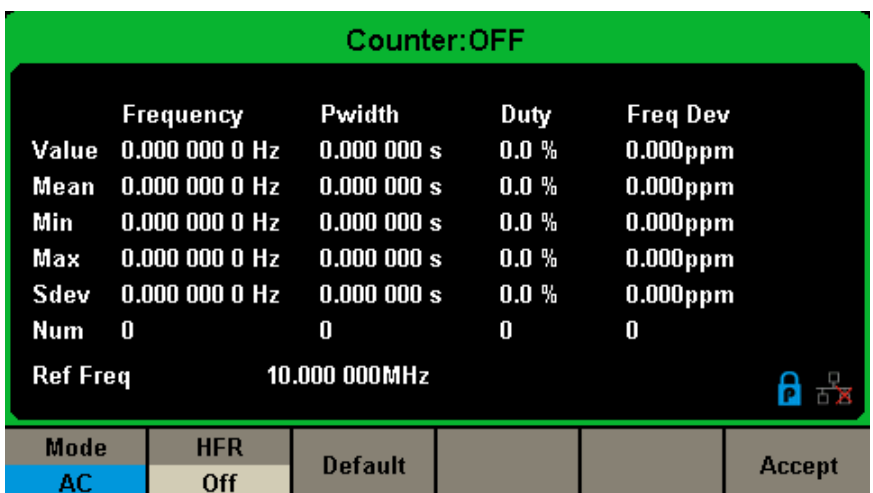

Figure 77: Counter Setup Interface

Function Menu	Settings	Explanations
Mode	DC	Set the coupling mode to DC
	AC	Set the coupling mode to AC
HFR	On	Turn on the high frequency rejection filter.
	Off	Turn off the high frequency rejection filter.
Default		Set the frequency counter settings to default.
Accept		Save the current settings and return to the previous menu.

**Table Menu Explanations of Setup**

**1. To Select the Parameters to be measured**

The frequency counter on the **GX 1030** can measure parameters including frequency, period, duty, positive pulse width and negative pulse width.

**2. Reference Frequency**

System will calculate the deviation between the measured frequency and the reference frequency automatically.

**3. Trigger Level**

Sets the trigger level of the measurement system. The system triggers and obtains the measurement readings when the input signal reaches the specified trigger level. The default is 0 V and the available range is from -3 V to 1.5 V. Choose TrigLev and use the numeric keyboard to input the desired value and select the unit (V or mV) from the pop-up menu. Or use the knob and arrow keys to change the parameter value.

**4. Coupling Mode**

Set the coupling model of the input signal to AC or DC. The default is AC.

**5. HFR**

High Frequency Rejection can be used to filter out the high-frequency components of a measured signal and improve the measurement accuracy in low-frequency signal measurement. Press [**HFR**] to enable or disable this function. The default is Off.

- Enable High Frequency Rejection when low-frequency signal with lower than a 250 kHz frequency is measured to filter out the high-frequency noise interference.
- Disable High Frequency Rejection when a signal with a frequency higher than 250 kHz is measured. The maximum frequency that can be counted is 200 MHz.

**7.4. OUTPUT**

Press [**Utility**] → [**Output Setup**] to enter the following interface.

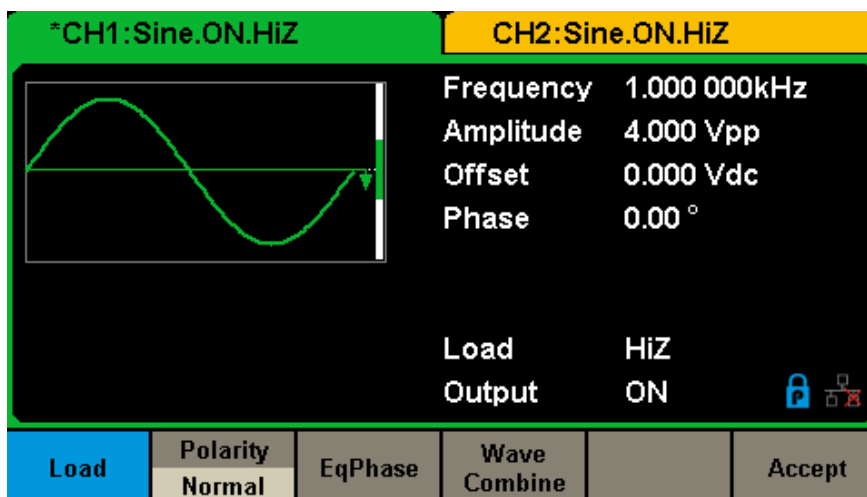

**Figure 78: Output Setup Interface**

**Load**

For the [CH1] and [CH2] connectors on the front panel, the generator has an output impedance of 50 Ω. If the actual load does not match the source impedance, the displayed voltage will not be the same as the output voltage setting on the generator. This function is used to match the displayed voltage with the expected one. This setting does not actually change the output impedance to any other value.

**Steps for setting the load:**

Press [Utility] → [Output Setup] → [Load], to set the output load. The load parameter shown on the down bottom is the default setting when the power is on or the pre-set load value.

High Impedance: displayed as HiZ.

**Load: the default is 50 Ω** and the range is 50 Ω to 100 kΩ.

**Note:** Continue pressing the corresponding output key for two second to switch between High Impedance and 50 Ω.

**Polarity**

Press [Utility] → [Output Setup] → [Polarity] to set the output signal as normal or inverted. The waveform's inversion is relative to the offset voltage, as shown in the following figure.

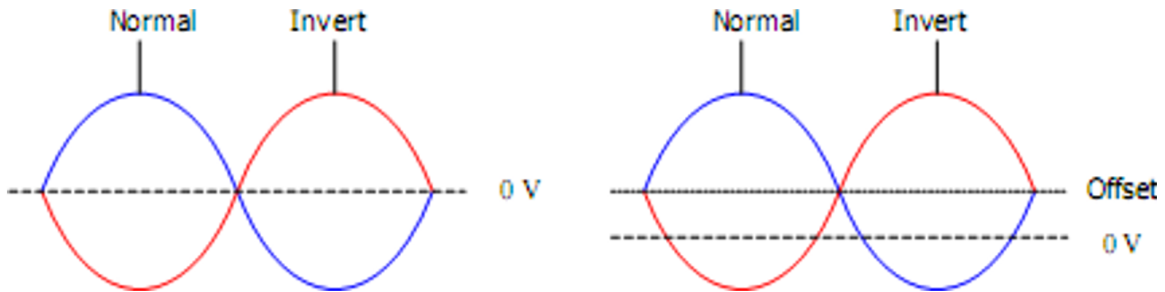

**Note:** The Sync signal related to the waveform is not inverted when the waveform is inverted.

**EqPhase**

Press [Utility] → [Output Setup] → [EqPhase] to align the phases of CH1 and CH2.

Choosing the menu will re-configure two channels and enable the generator to output with specified frequency and start phase. For two signals whose frequencies are the same or a multiple thereof, this operation will align their phases.

**Waveforms Combining**

The CH1 output port of the **GX 1030** outputs the waveform of CH1 in the general mode, while the waveform of CH1+CH2 can be output in the combined mode. Similarly, the CH2 output port of **GX 1030** outputs the waveform of CH2 in the general mode while the waveform of CH1+CH2 can be output in the combined mode.

Press [Utility] → [Output Setup] → [Wave Combine] to enter the waveforms combining interface, as shown in the following figure.

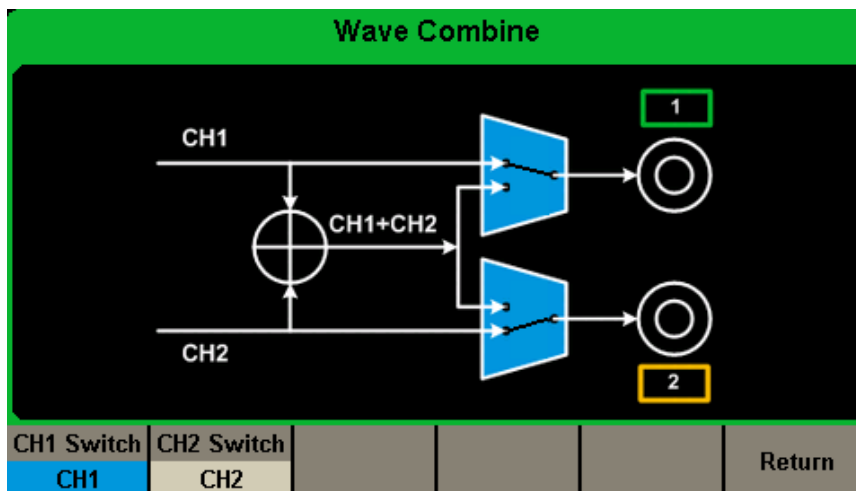

**Figure 79: Waveforms Combining Interface**

Function Menu	Settings	Explanations
CH1 Switch	CH1	Output the waveform of CH1.
	CH1+CH2	Output the waveform of CH1+CH2.
CH2 Switch	CH2	Output the waveform of CH2
	CH1+CH2	Output the waveform of CH1+CH2.
Return		Save the current operation and exit the current interface.

**Table Menu Explanations of Wave Combine**

**Note:**

1. The square waveform function of the **GX 1030** can only serve as an independent channel. Combining with a Square waveform is not possible.
2. When the waveforms combining function is enabled, the load of two channels will be set to the same automatically, default using the load value of the currently operated channel.

## 7.5. CH COPY/COUPLING

### 1. Channel Copy

The **GX 1030** supports state and waveform copy function between its two channels. That is to say, it copies all parameters and states (including the channel output state) and arbitrary waveform data of one channel to the other one.

Press **[Utility]** → **[CH Copy Coupling]** → **[Channel Copy]**, to enter the following interface.

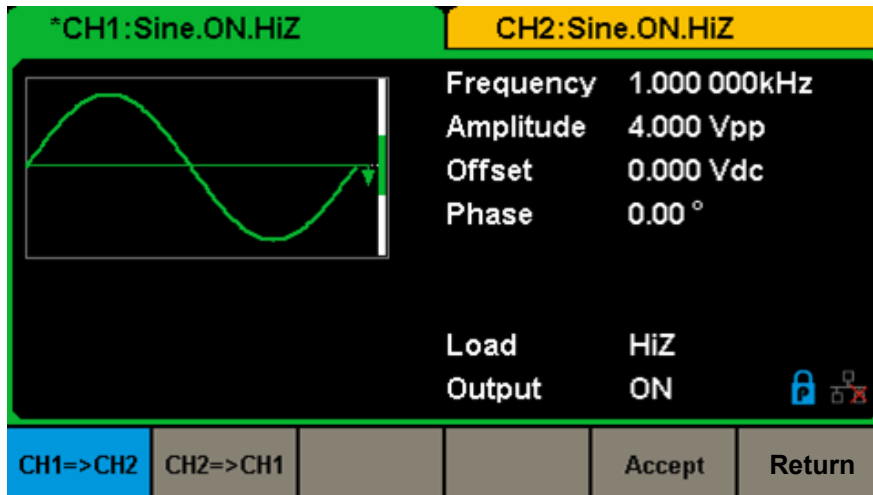

Figure 80: Channel Copy Interface

Function Menu	Settings	Explanations
CH1 => CH2		Copy all parameters and states of CH1 to CH2.
CH2 => CH1		Copy all parameters and states of CH2 to CH1.
Accept		Perform the current selection and return to the Utility menu.
Return		Give up the current selection and return to the Utility menu.

Table Menu Explanations of Channel Copy

**Note:** Channel coupling or track function and channel copy function are mutually exclusive. When channel coupling or track function is enabled, the menu **Channel Copy** is hidden.

### 2. Channel Coupling

The **GX 1030** supports frequency, amplitude and phase coupling. Users can set the frequency deviation/ratio, amplitude deviation/ratio or phase deviation/ratio of the two channels. When coupling is enabled, CH1 and CH2 can be modified simultaneously. When the frequency, amplitude or phase of one channel (as the reference) is changed, the corresponding parameter of the other channel will be changed automatically and always keeps the specified frequency deviation/ratio, amplitude deviation/ratio or phase deviation /ratio relative to the base channel.

Press **[Utility]** → **[CH Copy Coupling]** → **[Channel Coupling]**, to enter the following interface.



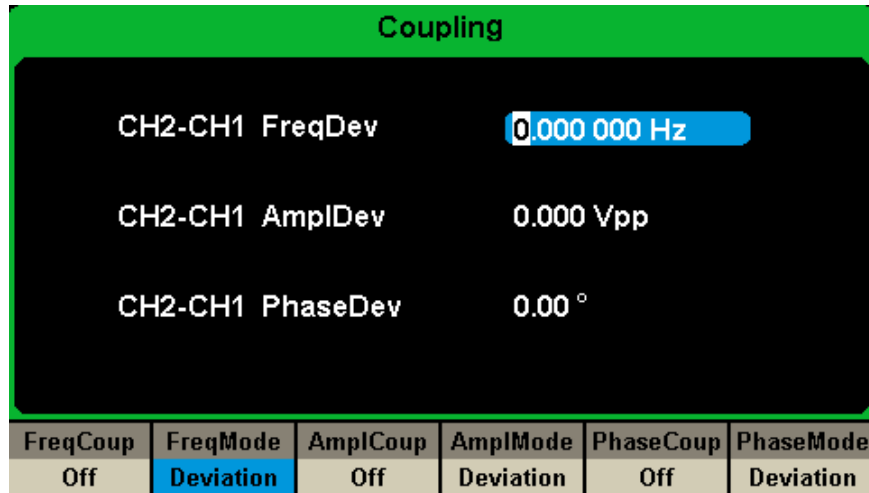

Figure 81: Channel Coupling Interface

### Frequency Coupling

- To Enable Frequency Coupling Function  
Press [**FreqCoup**] to turn frequency coupling On or Off. The default is Off.
- To Select Frequency coupling Mode  
Press **FreqMode** to choose Deviation or Ratio and then use the numeric keyboard or knob and arrow keys to input the desired value.
  - **Deviation**: the frequency deviation between CH1 and CH2. The resulting signal is represented by:  $\text{FreqCH2} - \text{FreqCH1} = \text{FreqDev}$ .
  - **Ratio**: the frequency ratio of CH1 and CH2. The resulting signal is represented by:  $\text{FreqCH2} / \text{FreqCH1} = \text{FreqRatio}$ .

### Amplitude Coupling

- To Enable Amplitude Coupling Function  
Press [**AmplCoup**] to turn amplitude coupling On or Off. The default is Off.
- To select Amplitude Coupling Mode  
Press [**AmplMode**] to choose Deviation or Ratio and then use the numeric keyboard or knob and arrow keys to input the desired value.
  - **Deviation**: the amplitude deviation between CH1 and CH2. The resulting signal is represented by:  $\text{AmplCH2} - \text{AmplCH1} = \text{AmplDev}$ .
  - **Ratio**: the amplitude ratio of CH1 and CH2. The resulting signal is represented by:  $\text{AmplCH2} / \text{AmplCH1} = \text{AmplRatio}$ .

### Phase Coupling

- To Enable Phase Coupling Function  
Press [**PhaseCoup**] to turn phase coupling On or Off. The default is Off.
- To Select Phase Coupling Mode  
Press [**PhaseMode**] to choose Deviation or Ratio, and then use the numeric keyboard or knob and arrow keys to input the desired value.
  - **Deviation**: the phase deviation between CH1 and CH2. The resulting signal is represented by:  $\text{PhaseCH2} - \text{PhaseCH1} = \text{PhaseDev}$ .
  - **Ratio**: the phase ratio of CH1 and CH2. The resulting signal is represented by:  $\text{PhaseCH2} / \text{PhaseCH1} = \text{PhaseRatio}$ .

### Key Points

- Channel coupling is only available when both the waveforms of the two channels are basic waveforms including Sine, Square, Ramp and Arbitrary.
- When the Phase Coupling function is enabled, if the phase of one channel is changed, the phase of the other channel will be changed accordingly. At this point, aligning phase between the two channels can be achieved without executing the **Eqphase** operation.
- Channel coupling and channel function are mutually exclusive. When channel coupling is enabled, the menu **Channel Copy** is hidden.

### Channel Track

When the track function is enabled, by changing the parameters or states of CH1, the corresponding parameters or states of CH2 will be adjusted to the same values or states automatically. At this point, the dual channels can output the same signal.

Choose **[Utility]** → **[CH Copy Coupling]** → **[Track]** to enable or disable the track function. When the track function is enabled, channel copy and coupling functions are disabled; the user interface is switched to CH1 and cannot be switched to CH2, as shown in the following figure.

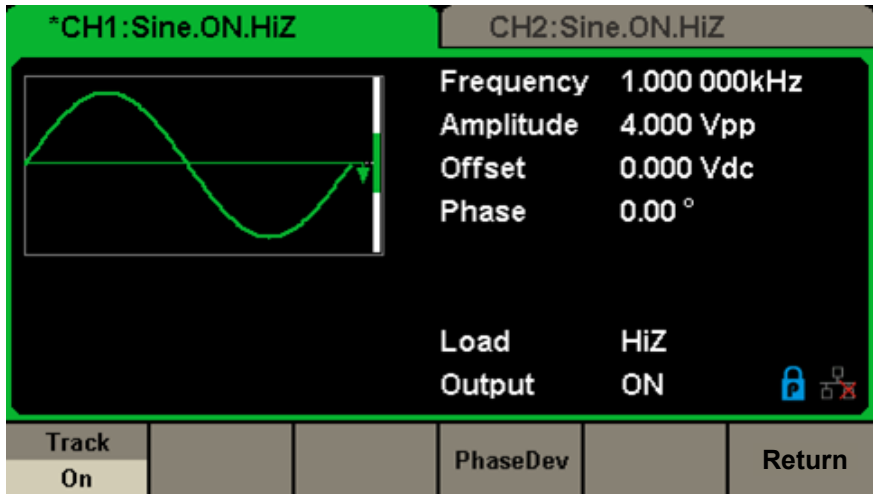

Figure 82: Track Interface

- Press **[PhaseDev]** to enter the following interface. Then use the numeric keyboard or knob and arrow keys to input the desired value for the phase deviation between CH1 and CH2. The resulting signal is represented by:  $\text{PhaseCH2} - \text{PhaseCH1} = \text{PhaseDev}$ .

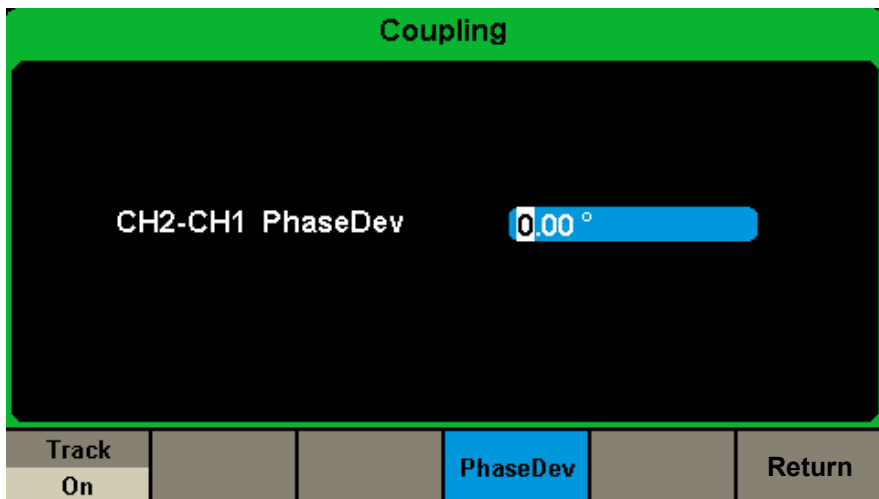

Figure 83: Phase Deviation Interface

## 7.6. REMOTE INTERFACE

The **GX 1030** can be controlled remotely via USB or, LAN interfaces. Users can set the corresponding interface according to their needs.

Press [**Utility**] → [**Page 2/2**] → [**Interface**] to open the following menu. The user can set LAN parameters or GPIB address.

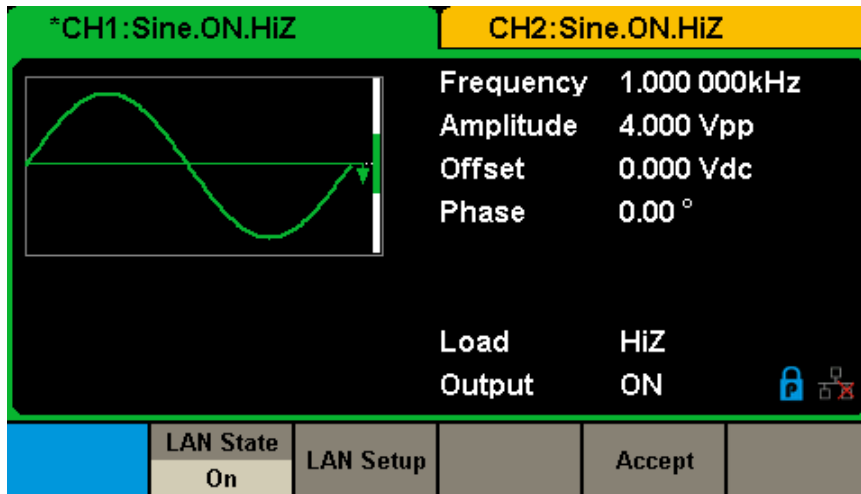

Figure 84: Interface Settings

Function Menu	Settings	Explanations
LAN State	On	Turn on LAN.
	Off	Turn off LAN.
LAN Setup		Set the IP address, subnet mask and gateway.
Accept		Save the current settings and return to the Utility menu.

Table Menu Explanations of Interface

The **GX 1030** can be controlled remotely via the following two methods:

### 1. User-defined programming

Users can program and control the instrument by using the **SCPI** commands (Standard Commands for Programmable Instruments). For more information about the commands and programming, please refer to **Remote Control Manual**.

### 2. PC Software

Users can use the PC software Measurement & Automation Explorer of **NI (National Instruments Corporation)** to send commands to control the instrument remotely.

### Remote Control via USB

The **GX 1030** can communicate with a PC through the USBTMC protocol. You are suggested to do as the following steps.

#### 1. Connect the device.

Connect the USB Device interface at the rear panel of **GX 1030** with the PC via a USB cable.

#### 2. Install the USB driver.

NI Visa is recommended.

#### 3. Communicate with a remote PC

Open Measurement & Automation Explorer of NI and choose the corresponding resource name. Then click Open VISA Test Panel to turn on the remote command control panel through which you can send commands and read data.

**EASYWAVE** on website:

[https://www.chauvin-arnoux.com/sites/default/files/download/easywave\\_release.zip](https://www.chauvin-arnoux.com/sites/default/files/download/easywave_release.zip)

or

**SX GENE** software on website:

[https://www.chauvin-arnoux.com/sites/default/files/download/sxgene\\_v2.0.zip](https://www.chauvin-arnoux.com/sites/default/files/download/sxgene_v2.0.zip)

## EASYWAVE X software

1. Running the EASYWAVE X software: double click the Easy wave shortcut, it will should below picture:

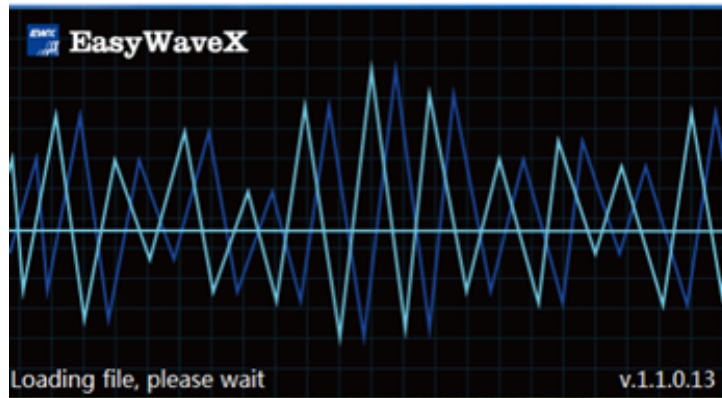

2. Waiting for loading file and then proceed to the next step.

3. Launch **EasywaveX**

4. Connection USB or LAN cable and select model.

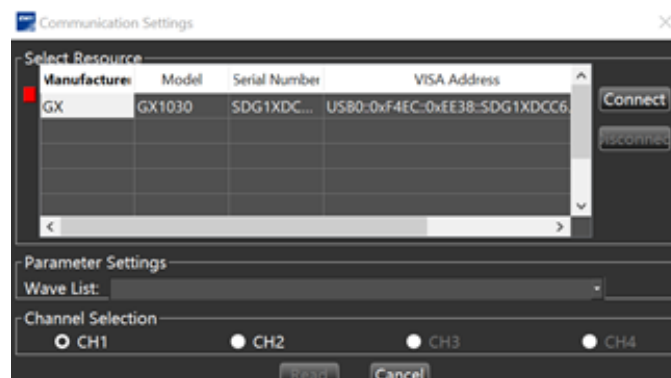

5. Select Waveform or built new arbitrary signal and follow help menu on software.

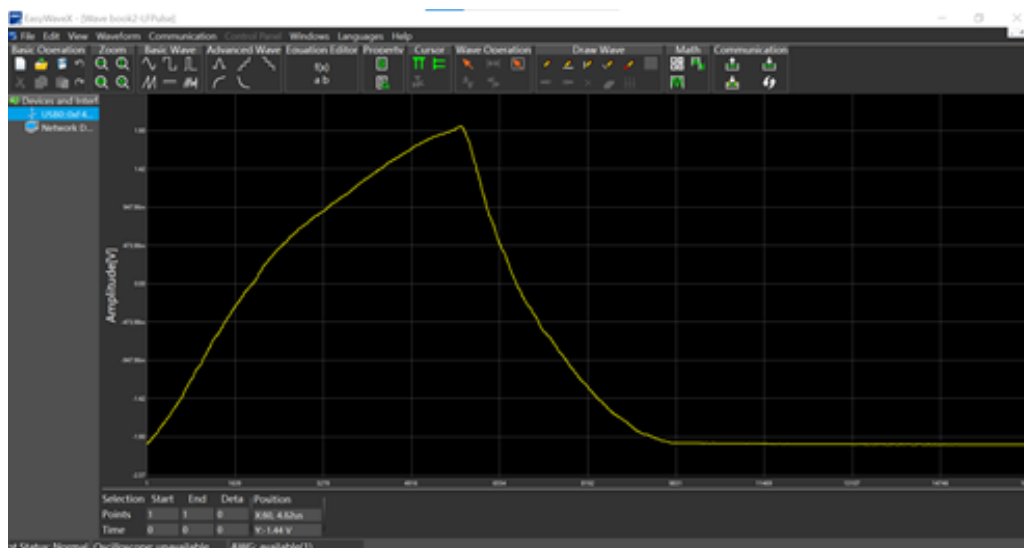

## SX GENE software

1. Running the SX-GENE version 2.1 software and using USB or Ethernet connection, follow "operating instructions" in pdf file.

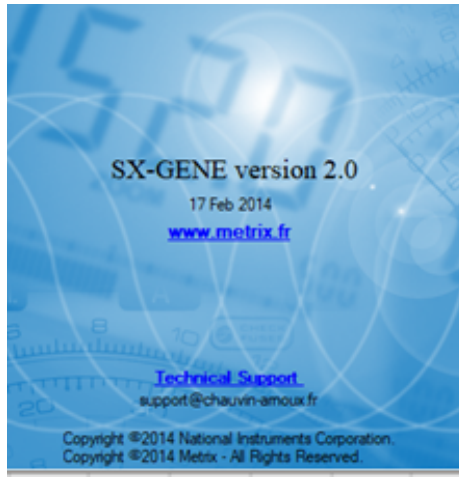

## SX-GENE allows

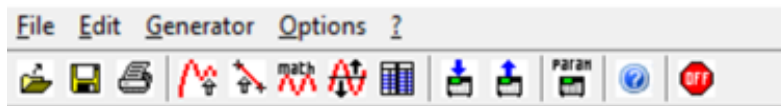

- Transfers of arbitrary signals **GX 1030**,
- The recovery of a signal from a METRIX oscilloscope curve (TRC file),
- Built new waveforms,
- Configuration of the generator.

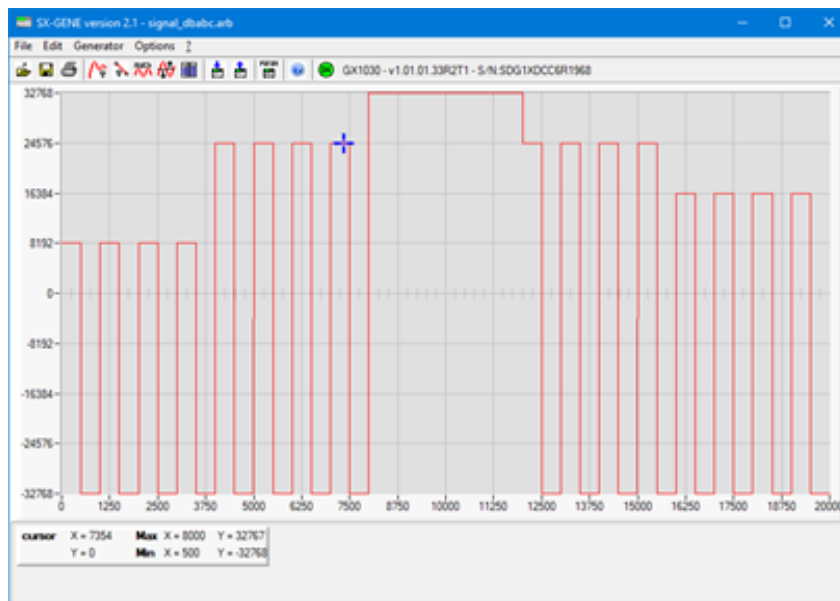

## Remote Control via LAN

The GX 1030 can communicate with a PC through LAN interface. Users can view and modify the LAN parameters.

### 1. Connect the device.

Connect the generator to your PC or the LAN of your PC using a network cable.

### 2. Configure network parameters.

Choose [Utility] → [Page 1/2] → [Interface] → [LAN State] to turn on LAN. Then choose LAN Setup to enter the following interface.

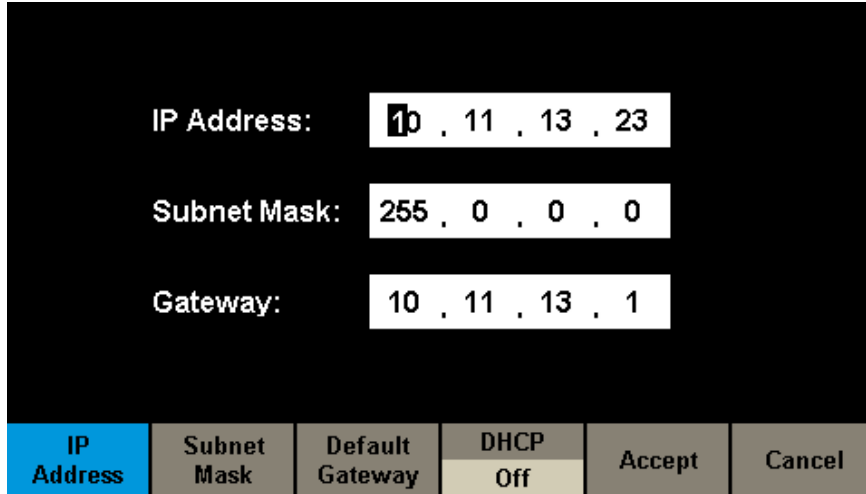

The screenshot shows a dark-themed interface with three input fields for network configuration. The first field is labeled 'IP Address:' and contains the value '10 . 11 . 13 . 23'. The second field is labeled 'Subnet Mask:' and contains '255 . 0 . 0 . 0'. The third field is labeled 'Gateway:' and contains '10 . 11 . 13 . 1'. Below these fields is a horizontal menu with six options: 'IP Address' (highlighted in blue), 'Subnet Mask', 'Default Gateway', 'DHCP Off' (with 'Off' on a separate line), 'Accept', and 'Cancel'.

Figure 85: LAN Settings Interface

#### To Set IP Address

The format of the IP address is nnn.nnn.nnn.nnn. The first nnn ranges from 1 to 223 and the others range from 0 to 255. You are recommended to acquire an available IP address from your network administrator.

Press [IP Address] and use the arrow keys and numeric keyboard or knob to enter your desired IP address. The setting is stored in non-volatile memory and will be loaded automatically when the generator is powered on the next time.

#### To Set Subnet Mask

The format of the subnet mask is nnn.nnn.nnn.nnn and each nnn ranges from 0 to 255. You are recommended to acquire an available subnet mask from your network administrator.

Press [Subnet Mask] and use the arrow keys and numeric keyboard or knob to enter your desired subnet mask. The setting is stored in non-volatile memory and will be loaded automatically when the generator is powered on the next time.

#### To Set Gateway

The format of the gateway is nnn.nnn.nnn.nnn and each nnn ranges from 0 to 255. It is recommended to acquire an available gateway from your network administrator.

Press [Gateway] and use the arrow keys and numeric keyboard or knob to enter your desired gateway. The setting is stored in non-volatile memory and will be loaded automatically when the generator is powered on the next time.

#### Note:

- If the generator is connected to the PC directly, set the IP addresses, subnet masks and gateways for both the PC and the generator. The subnet masks and gateways of the PC and generator must be the same and their IP addresses must be within the same network segment.
- If the generator is connected to the LAN of your PC, please contact with your network administrator to get an available IP address. For details, refer to the TCP/IP protocol.

#### DHCP Configuration Mode

In DHCP mode, the DHCP server in the current network assigns LAN parameters, e.g. IP address, for the generator. Press [DHCP] to select On Off to turn DHCP mode on or off. The default is Off.

### 3. Communicate with PC remotely

Open Measurement & Automation Explorer of NI. After adding the LAN device (VISA TCP/IP Resource...) successfully, choose the corresponding resource name. Then click Open VISA Test Panel to turn on the remote command control panel through which you can send commands and read data.

#### Using Easywave or SX GENE PC software

## 7.7. SYNC OUTPUT

The generator provides Sync output through the [Aux In/Out] connector on the rear panel. When the synchronization is on, the port can output a CMOS signal with the same frequency as basic waveforms (except Noise and DC), arbitrary waveforms, and modulated waveforms (except external modulation).

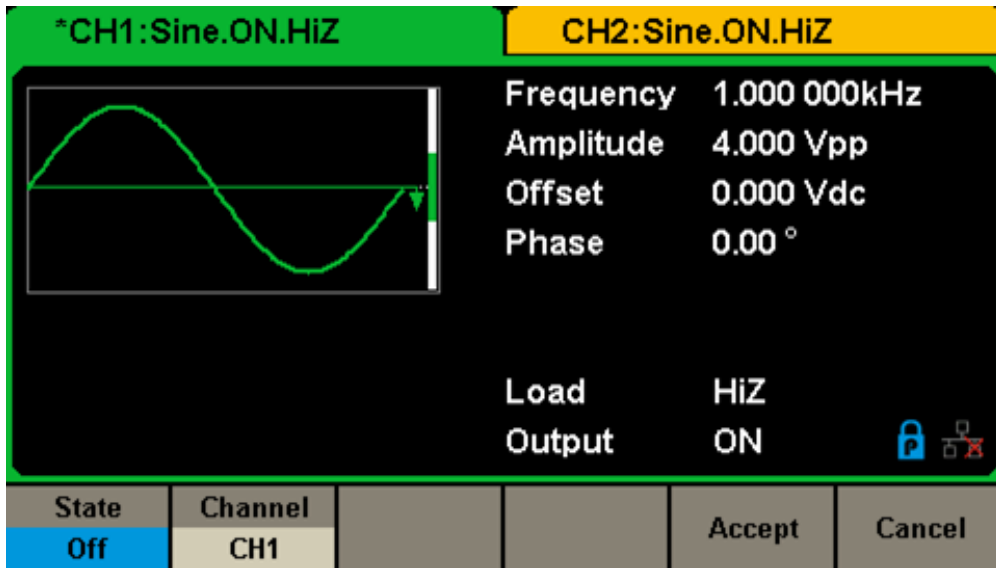

Figure 86: Sync Output Interface

Function Menu	Settings	Explanations
State	Off	Turn off the sync output.
	On	Turn on the sync output.
Channel type	CH1	Set the sync signal of CH1.
	CH2	Set the sync signal of CH2.
Accept		Save the current settings and return to the Utility menu.
Cancel		Give up the current settings and return to the Utility menu.

Table Menu Explanations of Sync Output

### Sync Signals of Different Waveforms:

#### Basic Waveform and Arbitrary Waveform

1. When the frequency of the waveform is less than or equal to 10 MHz, the sync signal is a Pulse with about 50 ns pulse width and the same frequency as the waveform.
2. When the frequency of the waveform is greater than 10 MHz, there is no sync signal output.
3. Noise and DC: there is no sync signal output.

#### Modulated Waveform

1. When internal modulation is selected, the sync signal is a Pulse with about 50 ns pulse width. For AM, FM, PM and PWM, the frequency of the sync signal is the modulating frequency. For ASK, FSK and PSK, the frequency of the sync signal is the key frequency.
2. When external modulation is selected, there is no sync signal output, for the [Aux In/Out] connector on the rear panel is used to input external modulating signal.

#### Sweep and Burst Waveform

When Sweep or Burst function is turned on, there is no sync signal output and the Sync menu is hidden.

## 7.8. CLOCK SOURCE

The **GX 1030** provides an internal 10 MHz clock source. It also can accept external clock source from the [10 MHz In/Out] connector at the rear panel. It can also output the clock source from the [10 MHz In/Out] connector for other devices.

Press **[Utility]** → **[Page 1/2]** → **[Clock]** → **[Source]** to select Internal or External and select Enable or Disable **10 MOut**. If External is selected, the **10 MOut** will be set to Disable and the instrument will detect whether a valid external clock signal is input at the [10 MHz In/Out] connector at the rear panel. If not, the prompt message No external clock source would be displayed and the clock source would be switched to Internal.

### Sync methods for two or more instruments:

#### ■ Synchronization between two instruments

Connect the [10 MHz In/Out] connector of generator A (using internal clock) to the [10 MHz In/Out] connector of generator B (using external clock) and set the output frequencies of A and B to the same value to achieve synchronization.

#### ■ Synchronization among multiple instruments

Divide the 10 MHz clock source of a generator (using internal clock) into multiple channels, and then connect them to the [10 MHz In/Out] connectors of other generators (using External clock), and finally set the output frequencies of all the generators to the same value to achieve synchronization.

## 7.9. PHASE MODE

Press **[Utility]** → **[Page 1/2]** → **[PhaseMode]** to enter the mode setup Interface, as shown in Figure 88 Mode Setup Interface.

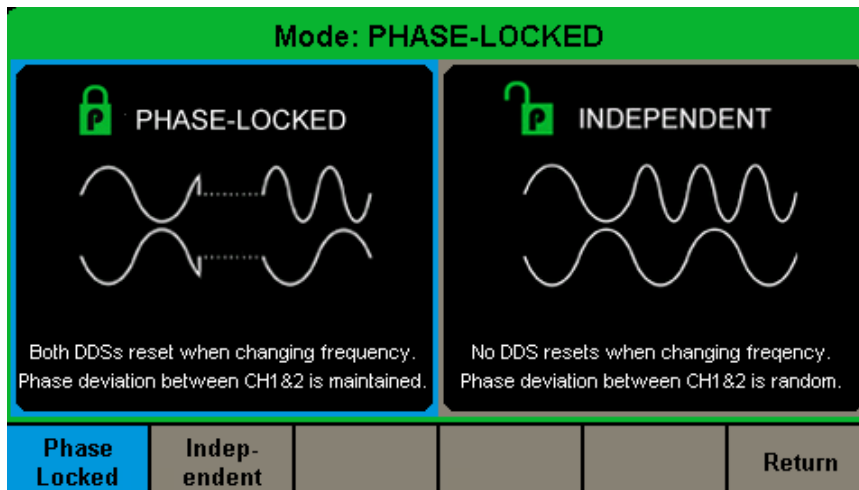

Figure 87: Mode Setup Interface

### Phase-locked Mode

When changing the frequency, the DDSs of both channels reset, and the phase deviation between CH1 and CH2 is maintained.

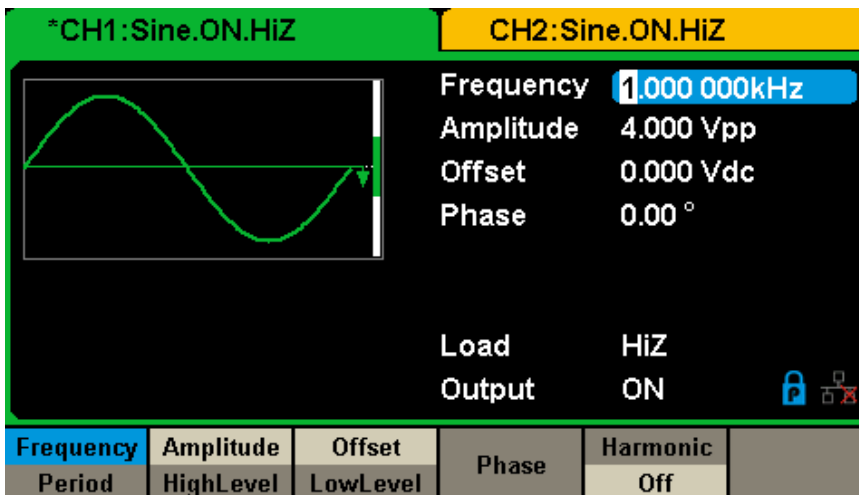

Figure 88: Phase-locked Mode



**Independent Mode**

When changing the frequency, neither channels' DDS resets and the phase deviation between CH1 and CH2 changes at random. When the independent mode is enabled, the phase parameter cannot be modified and the menu **Phase** is hidden, as shown in Figure 89.

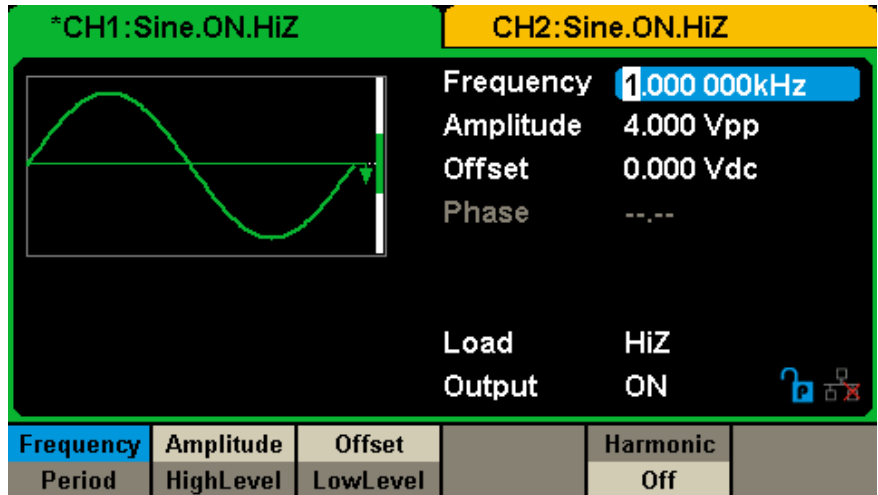

Figure 89: Independent Mode

**7.10. OVERVOLTAGE PROTECTION**

Choose [Utility] → [Page 2/2] → [OverVoltage Protection] to turn on or off the function, as shown in the following figure 90.

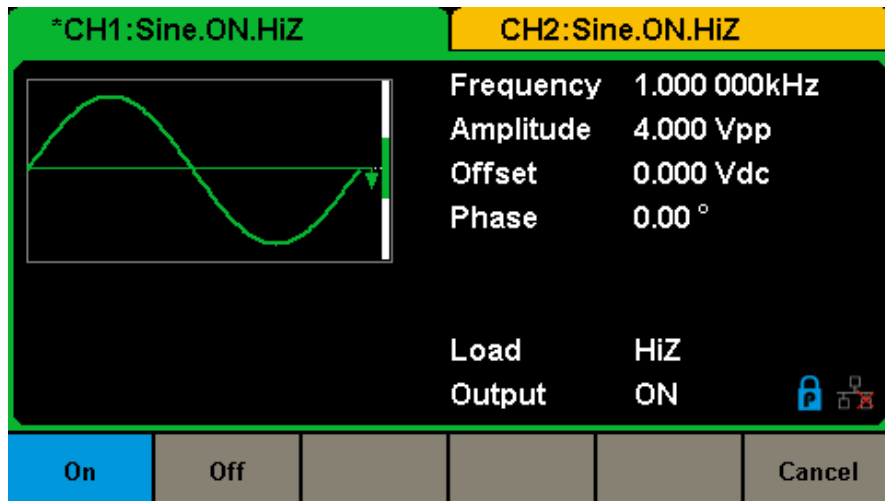

Figure 90: Overvoltage Protection Interface

If the state is set to ON, overvoltage protection of CH1 and CH2 will take effect once any of the following conditions is met. When overvoltage protection occurs, a message will be displayed and the output is disabled.

- The absolute value of input voltage is higher than  $11\text{ V} \pm 0.5\text{ V}$  when the amplitude of the generator is higher than or equal to 2 Vpp or the DC offset is higher than or equal to  $|3\text{ VDC}|$ .
- The absolute value of input voltage is higher than  $4\text{ V} \pm 0.5\text{ V}$  when the amplitude of the generator is lower than 2 Vpp or the DC offset is lower than  $|3\text{ VDC}|$ .

## 8. TROUBLE SHOOTING

### 1. After the generator is powered on, if the screen remains dark please do the following steps:

- Check the power cable's connection.
- Ensure the power switch is turned on.
- After the inspections above, restart the generator.
- If the generator still doesn't work after checking, please contact CHAUVIN ARNOUX.

### 2. If there is no waveform output after setting the parameters, please do the following steps:

- Check whether the BNC cable has a good connection to the output port.
- Check whether the output keys have been turned on.
- If the generator still doesn't work after checking, please contact CHAUVIN ARNOUX.

## 9. TECHNICAL SPECIFICATIONS



To satisfy these specifications, the following conditions must be met first:

1. The instruments have been operating continuously for more than 30 minutes within specified operating temperature range (18°C ~ 28°C).
2. You must perform the Self Cal operation if the operating temperature changes by more than 5°.

All specifications are guaranteed except those noted "typical value".

### 9.1. GENERAL

Max. output frequency	30 MHz
Output channels	2
Sample rate	150 MSa/s
Arbitrary waveform length	16 kpts
Frequency resolution	1 $\mu$ Hz initial accuracy -25/+25 ppm
vertical resolution	14 bits
Waveform	Sine, Square, Triangular, Pulse, Gaussian Noise, Ramp, Harmonic 196 types of arbitrary waveform
Sine	1 $\mu$ Hz ~ 30 MHz
Square	1 $\mu$ Hz ~ 30 MHz
Pulse	1 $\mu$ Hz ~ 12.5 MHz
Ramp/Triangular	1 $\mu$ Hz ~ 500 kHz
Gaussian white noise	30 MHz (-3 dB)
Arbitrary waveform	1 $\mu$ Hz ~ 6 MHz
Modulation	AM / FM / PM / FSK / ASK / PWM / Sweep / Burst
Resolution	1 $\mu$ Hz
Accuracy	within 1 year $\pm$ 100 ppm
Amplitude range	4 mVpp ~ 10 Vpp (50 $\Omega$ ) 4 mVpp ~ 20 Vpp high impedance <10 MHz
Other functions	Frequency counter: max. frequency 200 MHz
Standard interface	USB Host & Device, LAN
Dimension	W x H x D = 260.3 mm x 107.2 mm x 295.7 mm

## 9.2. WAVEFORMS SPECIFICATIONS

### 9.2.1. SINE WAVE SPECTRUM PURITY

Harmonic Distortion	DC - 10 MHz	-60 dBc
	10 MHz - 30 MHz	-50 dBc
Total harmonic waveform distortion	DC ~ 20 kHz 0.075 %	
Spurious signal non-harmonic	DC ~ 10 MHz < -65 dBc 10 MHz ~ 30 MHz < -55 dBc	

### 9.2.2. SQUARE WAVE

Rise / fall time 10 % ~ 90 % typical value 50 Ω 1 kHz 1 Vpp 1 kHz 2.5 Vpp	< 4.5 ns < 3.8 ns
Overshoot	< 3 % typical value 100 kHz 1 Vpp
Duty Cycle Min/max	0.001/99.999 % limited by frequency setting
Jitter 1 Vpp 50 Ω	300 ps + cycle 0.05 ppm of period

### 9.2.3. TRIANGLE / RAMP WAVE

Linearity	1 % of peak to peak output, typical value 1 kHz 1 Vpp, symmetric 50 %
Symmetry	0 % to 100 %

### 9.2.4. PULSE WAVE SPECIFICATION

Pulse width	32.6 ns min. resolution 1 ns
Rise/Fall time 10 % ~ 90 % typical value 1 kHz 1 Vpp	16.8 ns to 22.4 s
Overshoot	< 3 %
Jitter	300 ps + cycle 0.05 ppm of period

### 9.2.5. ARBITRARY WAVEFORM SPECIFICATION

Waveform length	16 kpts
Vertical resolution	14 bits include symbol
Sample rate	150 MSa/s
Jitter RMS	6.7 ns to 300 ps TrueArb mod, cycle-cycle rms, 2 pts, 20.1 MSa/s
Types of built-in Arb	196 waveforms

## 9.3. OUTPUT SPECIFICATION

Output	CH1	CH2
Amplitude	2 mVpp ~ 10 Vpp 50 Ohm ≤ 10 MHz 2 mVpp ~ 5 Vpp 50 Ohm > 10 MHz 4 mVpp ~ 20 Vpp high impedance ≤ 10 MHz 4 mVpp ~ 10 Vpp high impedance > 10 MHz	2 mVpp ~ 10 Vpp 50 Ohm ≤ 10 MHz 2 mVpp ~ 5 Vpp 50 Ohm > 10 MHz 4 mVpp ~ 20 Vpp high impedance ≤ 10 MHz 4 mVpp ~ 10 Vpp high impedance > 10 MHz
Vertical accuracy	≤ ± (1 % + 1 mVpp) 10 KHz sine, 0 V offset	
Amplitude flatness (compared to 10 kHz sine waveform 2.5 Vpp)	0.3 dB for f < 10 kHz	

## 9.4. DC OFFSET

Range DC	5 V (50 Ohm) 10 V (high impedance)
Offset accuracy	$\leq \pm (5 \% + 3 \text{ mV})$ setting offset value

## 9.5. WAVEFORM OUTPUT

Impedance	50 Ohm (typical value) or High Impedance
Protection	short-circuit protection see "Overvoltage Protection" menu

## 9.6. MODULATION

### 9.6.1. AM MODULATION CH1 / CH2

Carrier	Sine, Square, Ramp, Arbitrary
Source	Internal / External
Modulation waveform	Sine Square RAMP, Noise Arbitrary 1 mHz ~ 20 kHz
Modulation depth	0 % ~ 120 %

### 9.6.2. FM MODULATION CH1 / CH2

Carrier	Sine, Square, Triangle, Arbitrary
Source	Internal / External
Modulation waveform	Sine, Square, Ramp, Triangle, Gaussian Noise, Arbitrary 1 mHz ~ 20 kHz
Frequency deviation	0 ~ 0.5 BW BW is the max output frequency limited by frequency setting

### 9.6.3. PM MODULATION

Carrier	Sine, Square, Ramp, Arbitrary
Source	Internal / External
Modulation waveform	Sine, Square, Ramp, Triangle, Gaussian Noise, Arbitrary 2 mHz ~ 20 kHz
Deviation	0 % ~ 360 %

### 9.6.4. FSK MODULATION CH1/CH2

Carrier	Sine, Square, Triangle, Arbitrary
Source	Internal / External
Modulation waveform	50 % duty square waveform 1 mHz ~ 50 kHz

### 9.6.5. ASK/PSK MODULATION CH1/CH2

Carrier	Sine, Square, Triangle, Arbitrary
Source	Internal / External
Modulation waveform	50 % duty square waveform 1 mHz ~ 50 kHz

### 9.6.6. PWM MODULATION CH1/CH2

Frequency	1 mHz ~ 1 MHz while modulation source is internal
Source	Internal / External
Modulation waveform	Pulse
Pulse width deviation resolution	6.67 ns

## 9.7. SWEEP CH1 / CH2

Carrier	Sine, Square, Ramp, Triangle, Noise, Arbitrary
Type	linear / logarithmic
Direction	Up / down
Sweep time	1 ms ~ 500 s $\pm$ 0.1 %
Trigger source	Manual, external, internal

## 9.8. BURST CH1/CH2

Waveform	Sine, Square, Ramp, Pulse, Noise, Arbitrary
Type	Count 1 ~ 1 000,000 cycles infinite Gated
Start / Stop phase	0° ~ 360°
Internal cycle	1 $\mu$ s ~ 1000 s $\pm$ 1%
Gated trigger	External trigger
Trigger delay	100 s
Trigger source	Manual , External or Internal

## 9.9. REFERENCE CLOCK INPUT/OUTPUT

### 9.9.1. REFERENCE CLOCK INPUT

Frequency	10 MHz
Input impedance	5 k $\Omega$ AC coupling
Amplitude	1.4 Vpp

### 9.9.2. REFERENCE CLOCK OUTPUT

Frequency	10 MHz
Output impedance	50 k $\Omega$
Amplitude	3.3 Vpp

## 9.10. AUXILIARY IN/OUT CHARACTERISTICS

### 9.10.1. TRIGGER INPUT

V IH	2 to 5.5 V
V IL	-0.5 to 0.8 V
Input impedance	100 k $\Omega$
Pulse width	100 ns
Response time	100 ns Sweep 600 ns Burst

### 9.10.2. TRIGGER OUTPUT

V CH	3.8 V I CH = -8 mA
V OL	0.44 V I OL = 8 mA
Output impedance	100 $\Omega$
Frequency	1 MHz

**9.10.3. SYNC OUTPUT**

V CH	3.8 V I CH = -8 mA
V OL	0.44 V I OL = 8 mA
Output impedance	100 Ω
Pulse width	500 ns
Frequency	10 MHz
Jitter (pk-pk)	6.7 ns

**9.10.4. MODULATION INPUT**

Frequency	50 kHz
Amplitude@100%modulation depth	11 to 13 Vpp
Input impedance	10 Ω
Pulse width	100 ns
Response time	100 ns Sweep 600 ns Burst

## 10. REFERENCE CONDITIONS

Quantity of influence	Reference values
Temperature	20 ± 3°C
Relative humidity	< 90 %
Supply voltage	120 to 240 V
Frequency range	50/60 Hz

The operating uncertainty includes the intrinsic uncertainty plus the effects of variation of the quantities of influence (supply voltage, temperature, interference, etc.) as defined in standard IEC 61557-5.

The uncertainties are expressed in % of the reading (R) and in number of display points (pt): ± (a% R + b pt)

**Power supply**

Voltage 100 - 240 Vrms (± 10 %), 50/60 Hz - 50 W Max  
 100 - 120 Vrms (± 10 %), 400 Hz

**Display**

4.3" - 48 x 272 pts  
 Color depth 24 bit  
 Contrast ratio 350:1  
 Luminance 300 cd/m<sup>2</sup>

### 10.1. ENVIRONMENTAL CONDITIONS

- Indoor use
- In use                    0 to +40°C            5 to 90 % RH < 35°C
- Storage                   -20 to +60°C        5 to 95 % RH
- Degree of pollution    2
- Altitude                   < 2000 m (3048 m < 30°C)

### 10.2. MECHANICAL CHARACTERISTICS

Dimensions            (L x W x H): 260.3 x 107.2 x 295.7 mm (1.50 m cord)  
                               (L x D x H)  
 Weight                    approximately 4.35 kg

## 10.3. CONFORMITY TO INTERNATIONAL STANDARDS / ELECTRICAL SAFETY

The instrument is compliant with standard IEC/EN 61010-1

- Power supply: 240 V

## 10.4. ELECTROMAGNETIC COMPATIBILITY

The instrument is compliant with standard IEC/EN 61326-1

# 11. MAINTENANCE

---



The instrument contains no parts that can be replaced by personnel who have not been specially trained and accredited. Any unauthorized repair or replacement of a part by an "equivalent" may gravely impair safety.

## 11.1. CLEANING

If the instrument requires cleaning, disconnect it from all power sources and clean it with a mild detergent and water. Make sure the instrument is completely dry before reconnecting it to a power source.

To clean the exterior surface, perform the following steps:

- Remove loose dust on the outside of the instrument with a lint-free cloth. When cleaning the screen, be careful to avoid scratching the transparent plastic protective screen.
- Use a soft cloth dampened with water to clean the instrument.

**WARNING:** To avoid any damage to the surface of the instrument, do not use any abrasive or chemical cleaning agents.

Daily Maintenance: Do not store or leave the instrument in places where the display screen will be exposed to direct sunlight for a long period of time.

**CAUTION:** To avoid damage to the instrument, do not expose it to spray, liquid, or solvent.

## 11.2. UPDATING OF THE INTERNAL SOFTWARE

With a view to providing, at all times, the best possible service in terms of performance and technical upgrades, Chauvin Arnoux invites you to update the embedded software of the device by downloading the new version, available free of charge on our web site.

Our site:

<http://www.chauvin-arnoux.com>

Click on "Support", then "Access the download area", then enter the name of the instrument ("**GX 1030**").

Connect the device to your PC using the USB cord provided.

The update of the embedded software depends on its compatibility with the hardware version of the instrument.

This version is indicated in SET-UP.

Attention: updating the embedded software resets the configuration and causes the loss of the stored data. As a precaution, save the stored data to a PC before updating the embedded software.

## 12. WARRANTY

---

Except as otherwise stated, our warranty is valid for **24 months** starting from the date on which the equipment was sold. The extract from our General Conditions of Sale is available on our website.

[www.chauvin-arnoux.com/en/general-terms-of-sale](http://www.chauvin-arnoux.com/en/general-terms-of-sale)

The warranty does not apply in the following cases:

- Inappropriate use of the equipment or use with incompatible equipment;
- Modifications made to the equipment without the explicit permission of the manufacturer's technical staff;
- Work done on the device by a person not approved by the manufacturer;
- Adaptation to a particular application not anticipated in the definition of the equipment or not indicated in the user's manual;
- Damage caused by shocks, falls, or floods.



**metrix**

**FRANCE**

**Chauvin Arnoux**

12-16 rue Sarah Bernhardt

92600 Asnières-sur-Seine

Tél : +33 1 44 85 44 85

Fax : +33 1 46 27 73 89

[info@chauvin-arnoux.com](mailto:info@chauvin-arnoux.com)

[www.chauvin-arnoux.com](http://www.chauvin-arnoux.com)

**INTERNATIONAL**

**Chauvin Arnoux**

Tél : +33 1 44 85 44 38

Fax : +33 1 46 27 95 69

Our international contacts

[www.chauvin-arnoux.com/contacts](http://www.chauvin-arnoux.com/contacts)

